

# 13" TOP DRIVE PORTABLE AUGERS 72' & 82' MODELS

## OWNER'S & OPERATOR'S MANUAL

Effective August 28, 2023

Publication No. 1055146

This Manual is for Augers with Serial No's. HU06K292202176 or Higher

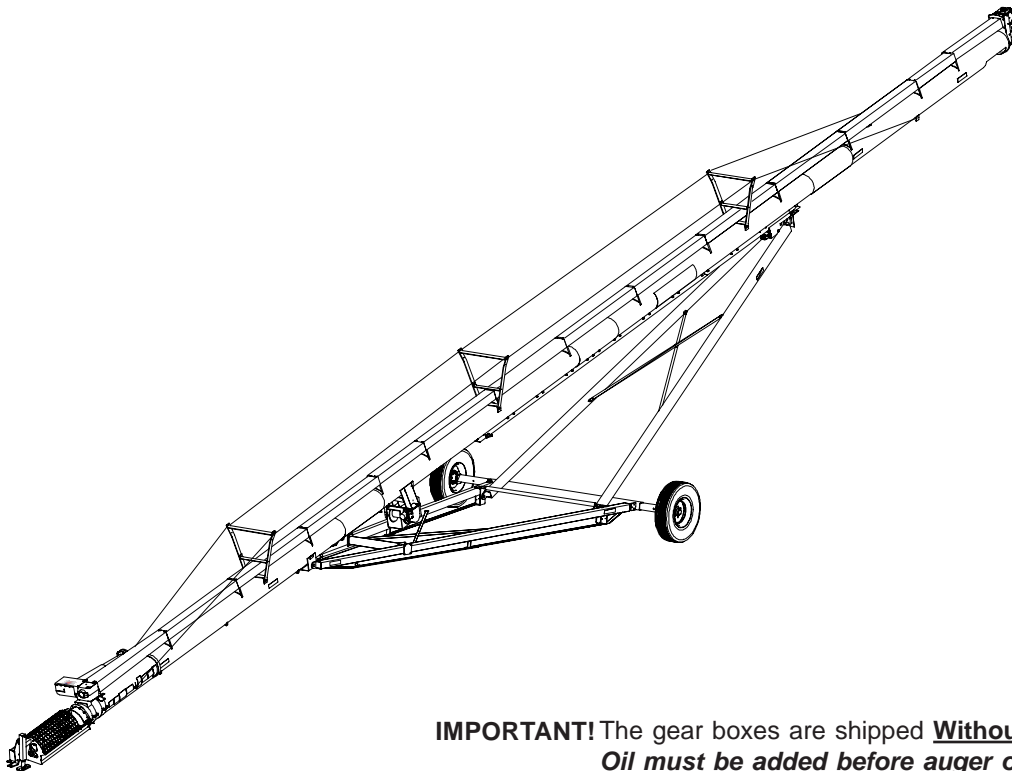

**IMPORTANT!** The gear boxes are shipped **Without Oil**.  
*Oil must be added before auger operation.*  
Refer to the Lubrication Section in this manual.



514 W. Crawford St. • Clay Center, KS. USA 67432  
P 785.632.2161 • F 785.632.5964 • TF 800.523.6993  
[aggrowth.com/hutchinson](http://aggrowth.com/hutchinson)

aggrowth.com | **AGI** 



# TABLE OF CONTENTS

<b>POLICIES AND PROCEDURES</b> .....	<b>(Inside Front Cover)</b>
<b>TABLE OF CONTENTS</b> .....	<b>1</b>
<b>SAETY</b> .....	<b>2 - 4</b>
General Safety Statement, Safety Alert Symbol .....	2
Safety Information (Emergencies, PPE, Grain Bin Safety, etc.) .....	2-4
Safety Decals .....	4
<b>GENERAL INFORMATION</b> .....	<b>5 - 8</b>
Operator Qualifications .....	5
Sign-Off Sheet, Right and Left Side Designation, Serial Number .....	5
Machine Inspection, Break-In Information .....	6
Operating Capacities .....	6
Electric Motor Drive Information .....	7
Tractor & PTO Requirements .....	8
<b>TRANSPORTING AUGER</b> .....	<b>9 - 12</b>
<b>TROUBLE SHOOTING</b> .....	<b>13</b>
<b>AUGER OPERATION</b> .....	<b>14 - 16</b>
Designated Work Area .....	14
Operating Procedures (Electric Models), Shutdown/Lockout .....	15
Operating Procedures (PTO Drive) .....	16
PTO Drive Shutdown/Lockout .....	16
<b>LUBRICATION &amp; MAINTENANCE</b> .....	<b>17 - 23</b>
General Maintenance Information .....	17
Inlet Bronze Bearing, Drive Shaft Bearings, Axle Bearings .....	17-18
Electric Drive Belt Adjustment .....	18-19
Hydraulic Components .....	19
Electric Winch .....	20-22
Gearbox f/ Electric & PTO Drive, PTO Driveline & Shear Bolt .....	22-23
Head Gearboxes .....	23
<b>ASSEMBLY INSTRUCTIONS</b> .....	<b>24 - 61</b>
Tube Section Layout .....	24-26
Head Gearbox to Head Section Assembly .....	27
Auger Housing & Flight Assembly .....	28
Track Assembly .....	29-30
Inlet Hopper, Hitch and Jack .....	31
PTO Drive Shaft, PTO Gearbox & PTO Driveline .....	32-35
Electric Drive Assembly .....	36-39
Drive Shaft Covers .....	40-41
Trolley & Trolley Stops .....	42
Under Truss & Truss Assembly, 62' & 65' Models .....	43-45
Undercarriage, 36' Models .....	46-47
Wheel Hub and Undercarriage, 62' & 65' Models .....	48-49
Winch & Wunch Cable, 36' Models .....	50-51
Hydraulic & Electric Winch, 36', 62' & 65' Models .....	52-54
Hydraulic Hose .....	55
Optional Collapsible & Flex Inlet Hoppers .....	56-59
Internal Bearing Assembly .....	60-61
<b>PARTS LIST TABLE OF CONTENT</b> .....	<b>62</b>
<b>PARTS LIST</b> .....	<b>P-1 - P-27</b>
<b>TORQUE CHART</b> .....	<b>P-28</b>

# SAFETY

## GENERAL SAFETY STATEMENT

This manual was written with the safety of the operator and others who work with the equipment as our prime concern. The instructions presented will help the reader learn **SAFE** day to day work practices. We want you as our partner in safety.

It is your responsibility as an owner, operator or supervisor to know what specific safety requirements and precautions exist and to make these known to all other personnel working with the equipment or in the area, so that they too may safely perform their duties and avoid any potentially hazardous situations.

**We suggest the implementation of a Safety Program for all personnel that includes, but is not limited to, the proper use of PPE (personal protective equipment), Fall Protection Systems and Lock Out-Tag Out procedures.**

Please remember safety equipment provides important protection for persons around a grain handling system that is in operation. Be sure **ALL** safety shields and protection devices are installed and properly maintained. If any shields or guards are damaged or missing, contact your dealer to obtain the correct items.

Avoid any alterations of the equipment. Such alterations may create a dangerous situation where serious injury or death may occur.

## SAFETY ALERT SYMBOL

The safety symbol shown is used throughout this manual to alert you to information about unsafe actions or situations, and will be followed by the word **DANGER, WARNING, or CAUTION.**

**DANGER** - Indicates immediate hazards that may result in severe injury or death. **WARNING** - Indicates unsafe actions or situations that may cause severe injury, death and/or major equipment or property damage. **CAUTION** - Indicates unsafe actions or situations that may cause injury, and/or minor property damage.

Watch this symbol - it points out important safety precautions. It means - **ATTENTION! Become alert! Your safety and the safety of others is involved!** Read the message that follows the symbol when a warning is given, be alert to the possibility of personal injury or death.



### Follow Safety Instructions

Carefully read all safety messages in this manual and safety signs on your machine. Check to ensure all Safety Decals are present and in good condition.

If a decal cannot easily be read for any reason, or has been painted over, replace the decal immediately. Safety decals are offered free of charge, and can be ordered through your Hutchinson/Mayrath dealer or directly from the factory.

Learn how to operate the machine and how to use controls properly.

Keep your machinery in proper working condition. Understand service procedures before doing work. Never lubricate, service or adjust machine while it is in operation.

Keep work area clean, dry and free from of all debris and tools which may cause accidental tripping or falling.



**Read and Understand Manual**

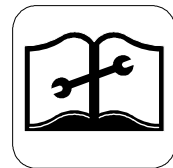

**Understand Service Procedures**



**Keep Work Area Clean**

### Prepare for Emergencies

Keep emergency numbers for doctors, ambulance service, hospital and fire department near your telephone.

Keep a first-aid kit and fire extinguisher handy.

Be prepared if a fire starts

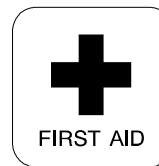

**First Aid Equipment**



**Fire Extinguisher**

## **Wear Proper PPE (Personal Protective Equipment)**

Some materials can create flying debris when they are filed, cut or drilled. Safety glasses should be worn at all times to protect your eyes from such debris.

Hearing protection should be worn when operating power tools or other power equipment that could be harmful to your hearing.

Gloves should be worn to protect your hands from sharp metal and plastic edges, as well as providing protection from the handling of heavy objects.

Wear steel toe boots to protect your feet from falling debris.

Wear a hard hat to help protect your head from falling objects as well as from accidental bumping.

Use caution when working at elevations greater than four (4) feet (1.22 m) above the ground.

Use the appropriate fall protection equipment as set forth by OSHA guidelines and regulations.

A respirator may be needed to prevent breathing potentially toxic fumes and dust, especially when working within a grain bin or storage structure.

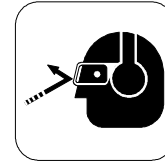

Eye & Hearing Protection

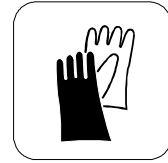

Gloves



Steel Toe Boots



Hard Hat



Fall Protection

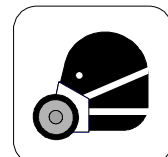

Respirator

## **Operate Electric Motor(s) Properly**

Do not operate electric motor equipped units until motor(s) are properly grounded.

Know how to "Shutdown and Lockout" the power source. Shutdown and lockout power source before performing any service, maintenance or adjustments to the unit.

Disconnect power on electrical driven units before resetting motor overloads.

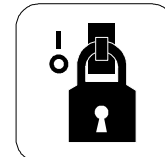

Lockout / Tagout



Electric Shock Hazard

## **Stay Clear of Moving Parts**

Keep all shields, covers and safety devices in place at all times.

Entanglement in moving chains, rotating impeller arms and sprockets will cause serious injury or death.

Wear close fitted clothing. Keep hands, feet and clothing away from moving parts.

Shutdown and lockout power source before making adjustments, cleaning or maintaining the equipment.

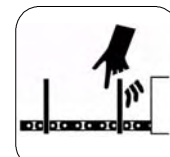

Entanglement Hazards

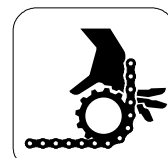



# SAFETY

## GRAIN BIN SAFETY

The Top Drive Auger is generally designed to move grain into grain bins or other storage structures. **Be aware of the dangers inherent in grain bins.**

Consult the grain bin manufacturer's manual for information on the proper loading and unloading of the bins, structural stress analysis, adequate venting and important safety information.

**WARNING! Do Not enter the bin if the grain has "Bridged" or has not flowed normally out of the bin, See Example's 1 & 2. The grain may suddenly break loose and bury resulting in suffocation.**

**Do Not enter the bin unless all power driven equipment has been shut down and locked out.**

**Never enter the bin unless monitored by another person.**

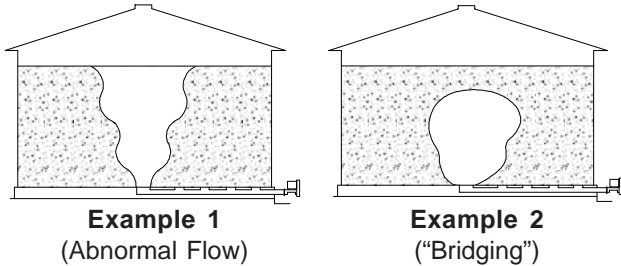

## SAFETY DECALS

Check to ensure all Safety Decals are present and in good condition. If a decal cannot easily be read for any reason, or has been painted over, replace the decal immediately. Safety decals are offered free of charge, and can be ordered through your Hutchinson/Mayrath dealer or directly from the factory.

Refer to the Parts List Section for decal Part No's. and decal locations.



**⚠ DANGER**



**SHIELD MISSING  
DO NOT OPERATE**

**⚠ DANGER**



**SHIELD MISSING  
DO NOT OPERATE**

**⚠ DANGER**

**⚠ DANGER**



**ROTATING DRIVELINE**  
CONTACT CAN CAUSE DEATH  
KEEP AWAY!

DO NOT OPERATE WITHOUT -

- ALL DRIVELINE TRACTION AND EQUIPMENT SHIELDS IN PLACE
- DRIVELINES SECURELY ATTACHED AT BOTH ENDS
- DRIVELINE SHIELDS THAT TURN FREELY IN DRIVELINE

**⚠ WARNING**



**TRANSPORT HAZARD**

To prevent serious injury or death:

- The transport width exceeds 8'6"
- When towing over public roads, be aware of traffic and obstructions along the roadway.

1901975-1

**⚠ WARNING**

To prevent serious injury or death:

- Read and understand the manual before assembling, operating, or maintaining the equipment.
- Only trained personnel may assemble, operate, or maintain the equipment.
- Children and untrained personnel must be kept outside of the work area.
- Do not modify the equipment. Keep in good working order.
- If the manual, guards, or decals are missing or damaged, contact factory or representative for free replacements.
- Lock out power before performing maintenance.
- To prevent equipment collapse or upending, support equipment tube while disassembling certain components.
- Electric motors must be grounded. Disconnect power before resetting overloads.

8112-0007 1901973-1



## WARNING!

Anyone who will operate or work around this machine shall first read this manual! This manual must be delivered with the equipment to its owner. Failure to read this manual and its safety instructions is a misuse of the equipment.

## OPERATOR QUALIFICATIONS

Operation of this auger shall be limited to competent and experienced persons. In addition, anyone who will operate or work around an auger must use good common sense. In order to be qualified, the operator must also know and meet all other requirements, such as:

1. Some regulations specify that no one under the age of 16 may operate power machinery. This includes this auger. It is your responsibility to know what these regulations are in your area or situation.
2. Current OSHA regulations state in part: "At the time of initial assignment and at least annually thereafter, the employer shall instruct every employee in safe operation and servicing of all equipment which the employee is, or will be involved with." \*
3. Unqualified persons are to stay out of the work area. See "Designated Work Area" section.
4. A person who has not read and understood all operating and safety instructions is not qualified to operate the machine.
5. Person's operating, servicing or repairing equipment that requires above ground work shall be properly secured with the use of "fall protection" equipment as set forth by OSHA guidelines and regulations.

\*Federal Occupational Safety & Health Standards for Agriculture Subpart D, Section 1928.57 (a) (6).

## SIGN-OFF SHEET

As a requirement of OSHA, it is necessary for the employer to train the employee in the safe operation and safety procedures with this auger.

We include this sign off sheet for your convenience and personal record keeping.

<u>Training Sign-Off Sheet</u>		
Date	Employer Signature	Employee Signature

## RIGHT and LEFT SIDE DESIGNATION

When referencing the left, right, front or rear of the unit, it is always determined by standing at the inlet end of the auger and looking towards the discharge end.

## SERIAL NUMBER

To ensure efficient and prompt service, please furnish us with the model and serial no. of your auger in all correspondence or other in all other means of contact. The serial no. plate is located on the right side of the lower undercarriage mount.

# GENERAL INFORMATION

## MACHINE INSPECTION

Our augers are well made and we are proud of our line of equipment. We would like you, as our customer, to do your part in using caution and good judgement in using our equipment, as well as any other machinery.

**After delivery of your new auger and/or completion of assembly and before each use, inspection of the machine is mandatory.** This inspection should include, but not be limited to:

1. Check to see that all guards listed in the assembly instructions are in place, secured and functional. All shields on the PTO drive must rotate freely.
2. Check all safety signs (decals) and replace any that are worn, missing or illegible. Safety signs may be obtained free of charge from your dealer or ordered from the factory.
3. Check **all** fasteners; nuts, bolts, set screws etc. for tightness.
4. Check oil levels in gearboxes (See the Lubrication and Maintenance Section).
5. Check all hydraulic hoses, and fittings to ensure they are tight and not leaking hydraulic oil.

## GENERAL AUGER INFORMATION



**WARNING! During initial start-up and break-in period, the operator shall be aware of any unusual vibrations or noises that would indicate a need for service or repair.**



**Keep all safety shields and devices in place. Keep hands, feet, and clothing away from moving parts.**



**The operator should have a full view of the auger work area and check that all personnel are free from designated work areas before adding power.**

- Obtain any needed replacement parts from your dealer and install **before** using the machine.
- It is important to become familiar with the routine operating procedures before attempting start-up.
- Inspect the drive before adding power and know how to **shutdown** in an emergency (See Pages 15 & 16).
- During operation of your auger, one person shall be in a position to monitor the operation.
- Visually inspect the auger periodically during operation, be aware of all adjustments and checks which should be performed.

*General Information (con't.)*

- **Do Not** attempt full load operation at low speeds, as high torque requirements may damage the auger.

## BREAK-IN INFORMATION

Any auger when it is new, or after sitting idle for a season should go through a “break-in” period. The auger should be run at partial capacity until several hundred bushels of grain have been conveyed to polish the housing and flight. An auger that has not been polished in this manner requires greater horsepower to operate, and damage to conveyor can occur.

When the housing and flight has been polished and smooth, the auger can be run at full capacity. Never run an auger empty for any length of time as excessive wear will result. If at all possible, do not stop or start the auger under load, especially before the housing has become well polished, as this may cause the auger to “freeze-up.”

**IMPORTANT! The auger should be frequently checked and serviced to operate freely. Keep all guards and shields in place, replace any that are damaged or missing.**

## OPERATING CAPACITIES

The 13” augers have the ability to convey **7,250 Bushels Per Hour (196 TPH)** of reasonably dry grain during normal operating conditions.

Maximum possible capacity will be less with high moisture grain (above 15%) than with dry grain. Twenty-five percent (25%) moisture could cut capacity back by as much as 40% under some conditions.

The results or capacities of augers can vary greatly under varying conditions. Different materials, moisture content, amounts of foreign matter, angle of operation, methods of feeding and auger speed all play a role in the performance of the auger.

Overfeeding the auger would result in increased power requirements, extra strain on the driveline and possibly a complete stalling out.

Under the “extra” grain pressure conditions, a control gate or other method of limiting the amount of grain being fed into the auger should be used.

## LAYOUT & ASSEMBLY INFORMATION

For ease of assembly and locating hardware, the auger has been divided into two different groups. **These groups are; the main auger tube assembly and the undercarriage assembly.**

The boxes of parts are separated so that each box contains the components and hardware needed to assemble that particular group.

**For example:** the main box of parts for the auger also includes the box(es) containing the hardware and components that are necessary for assembly of just the undercarriage group, and the box(es) of hardware and components necessary to assemble just the main tube grouping.

**Refer to Page P-1 for information on the box of parts for each group.**

## ELECTRIC DRIVE POWER REQUIREMENTS

The auger can be operated using an electric drive motor. Always use a motor with the required power recommended shown in the chart. Use a motor that operates at 1750 RPM.



**WARNING!** Shut off power and lockout whenever cleaning or servicing the auger.

The reset and starting controls must be located so that the operator has full view of the entire operation.



Disconnect power before resetting motor overloads.

Make certain electric motor is grounded.

Keep hands, feet and clothing away from moving parts.



Keep all safety shields and devices in place.

A main power disconnect switch that can be locked in only the "Off" position shall be provided. This shall be locked whenever work is being done to the auger.



Do Not enter the grain bin unless all power driven equipment has been shutdown and locked out.

**Electric motors and controls shall be installed by a qualified electrician and must meet the standards set by the National Electric Code and all local and state codes.**

A magnetic starter should be used to protect your motor when starting or stopping. It should stop the motor in case of power interruption, conductor fault, low voltage, circuit interruption and/or motor overload. The motor should then be restarted manually.

A main power disconnect switch that can be locked only in the "Off" position shall be provided. This shall be locked whenever work is being done to the auger.

### **Recommended Auger Speed**

The 12.4" driven sheave *is* provided with the unit. We recommend a 7.4" P.D. motor sheave to obtain a maximum auger speed of 556 rpm (the 7.4" P.D. motor sheave is **Not** provided).

A 13.6" driven sheave (not furnished) can be substituted for the 12.4" sheave, which will then reduce auger speed to 508 rpm's.

### **Recommended Sheaves**

**12.4" driven sheave, provided - 556 rpm max.**

**13.6" driven sheave, not provided - 508 rpm**

**7.4" P.D. drive (motor) sheave, not provided**

**12.4" Sheave @ 556 rpm's - 7250 BPH (196 TPH)**

**13.6" Sheave @ 508 rpm's - 7100 BPH (192 TPH)**

### **Horsepower Recommendations for**

**13" x 72' and 13" x 82' Top Drive Models**

Auger Length	Recommended Horsepower (kW)	Recommended Motor Sheave*
72'	40 hp (30 kW)	7.4" P.D. 4B
82'	50 hp (37kW)	7.4" P.D. 5B

\* Motor Sheave **Not** provided  
P.D. = Pitch Diameter

**NOTE:** Speeds greater than what is recommended can cause excessive wear and/or damage to the auger and its components.

# GENERAL INFORMATION

## TRACTOR & PTO REQUIREMENTS

The auger PTO was designed for use with a tractor that is capable of operating at 1000 RPM's (speeds greater than this will cause excessive wear and/or damage to the conveyor).

**NOTE: The PTO driveline furnished with this auger is equipped with a "Spring-Lok" coupler at the tractor end. This type of coupler is spring loaded and will fit the standard 1 3/8" x 21 spline tractor PTO shaft.**

The PTO driveline is also equipped with a shear bolt at the tractor connection. The shear bolt protects the auger from damage should the auger become plugged or subjected to high loads. If this scenario should occur, the shear bolt would "shear off" causing the connection to the auger to suddenly stop (the tractor PTO will continue turning, but not the auger driveline). **Immediately shutdown the tractor and lockout before attempting to investigate the cause of the problem.**

Extra shear bolts are located in the operator's manual container. **Always use the same size and strength shear bolts (3/8-16 x 1" grade 8 PLT).**

The tractor should also be equipped with an adjustable drawbar, the proper horsepower required for the size of auger being used and have a hydraulic control circuit capable of producing 1400 to 1500 PSI for the hydraulic winch used for raising and lowering the main auger (See chart below for minimum pressure requirements).

**PTO operating @ 1000 rpm's from tractor = 533 rpm's auger speed - 7250 BPH (196 TPH)**

<b>Auger Size</b>	<b>13" x 72'</b>	<b>13" x 82'</b>
<b>Tractor Hydraulic for Auger Lift</b>	1500 PSI	1500 PSI
<b>Approx. PTO Horsepower</b>	75-90 HP	75-90 HP

## PTO DRIVELINE/TRACTOR CONNECTION

### Keep PTO Driveline as Horizontal as Possible

Some bin site applications may have the tractor and auger on unlevel ground, or both may be positioned at different levels. It's important to align the tractor so the PTO driveline is as horizontal as possible (See illustration below).

**Do Not operate the PTO at severe angles. Damage to the PTO and/or auger can occur.**

The tractor axle should also be parallel (at a 90° angle) with the side of the auger when connection is made.

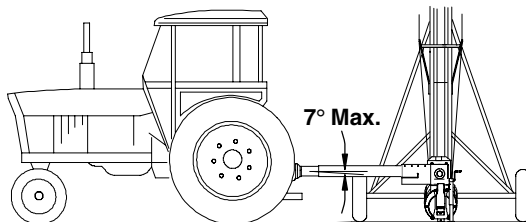
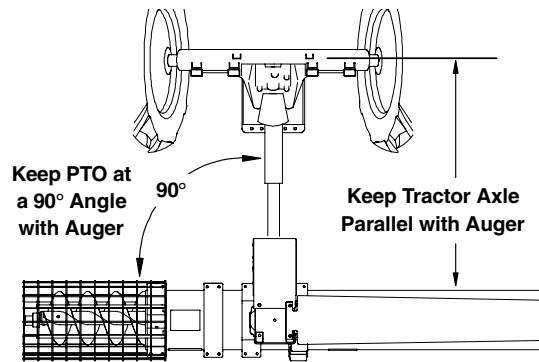

**Keep PTO Driveline in a Straight a Line as Possible**

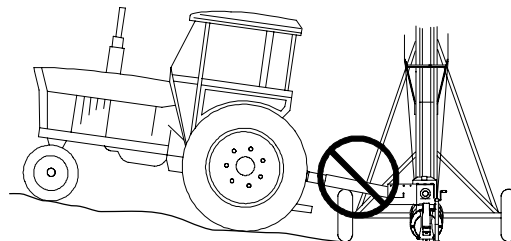

**Do Not Operate at Severe Angles**

## ATTACH AUGER to TOWING VEHICLE

**WARNING!** Never stand between the tractor and auger when hitching or unhitching, unless the controls are in neutral and the brakes are locked.

Never allow persons to stand underneath or ride on the auger as it is being transported.

Never raise the hitch end higher than necessary to attach to the towing vehicle (weight transfers rapidly to the discharge end as the hitch end is being raised, particularly when the auger is in the raised position).

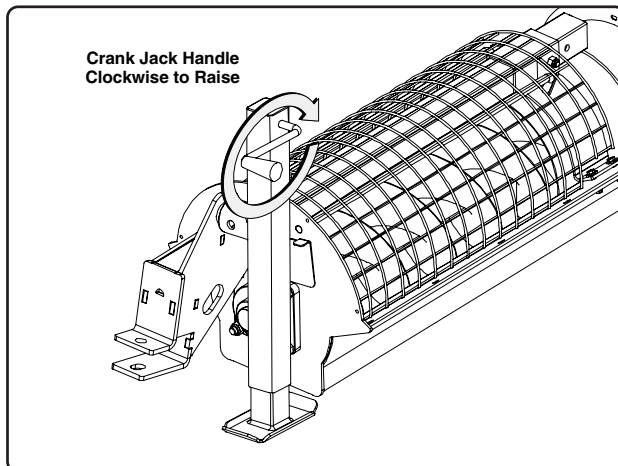

Fig. 1

1. The hitch jack is intended to lift the intake end of the auger for hitching and unhitching purposes. Depending on the position of the auger (raised or lowered) the jack needs to be as vertical to the ground as possible when being used.

Remove the pin and rotate jack accordingly. Reinstall and secure the pin once the jack is positioned.

Crank the jack winch handle clockwise to extend the jack. **Raise the intake end of the auger only high enough to allow connection to the drawbar of the toeing vehicle.**

2. Secure the auger hitch to the tractor drawbar with hitch and clevis pin (a bolt, flat washers and nuts can also be used, just make sure hitch is securely attached).

**An auxiliary attachment system (safety chain) is required when transporting on public roads. Its function is to retain the connection between the towing and towed machines in the event of separation of the primary attachment system.**

3. Fasten one end of a safety chain (not furnished) to the drawbar on the towing vehicle and loop the other end through the opening above the hitch plates (See illustration below).

A clevis or similar type of intermediate support for the chain should be fastened to the drawbar no farther than 6" from the hitch pin (See illustration below).

Once auger is attached to towing vehicle, raise the jack stand to the appropriate transport position.

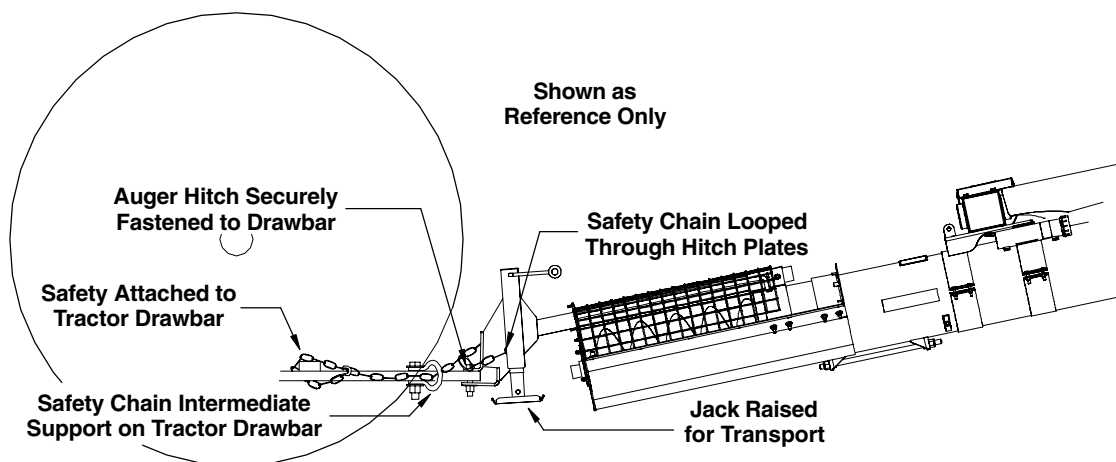

# TRANSPORTING AUGER

## PLACEMENT of AUGER for FILLING GRAIN BIN

 **CAUTION!** Make sure entire area above auger and the path of travel is clear of overhead obstructions and electrical wires. Failure to do so can result in electrocution (maintain at least 10 feet of clearance from power lines, *electrocution can occur without direct contact of the power lines*).

 To prevent tip-over when backing, avoid rolling over any obstructions and avoid steep slopes. If the auger is to be set on a slope, approach the bin uphill. Avoid moving the auger at right angles to a slope.

 Make sure everyone is clear of the work area when moving the auger. Keep hands clear of the winch drum when winch is in operation.

- Auger should be placed on as level a surface as possible (the wheels must be allowed to roll freely as the auger is being raised).
- When positioning the auger into its working position, make sure to leave adequate room for the loaded vehicles to reach the inlet hopper.

### STEP 1: Locate Auger Next to Bin

1. Move the auger into its working position with a towing vehicle (See Fig. 2). Locate the auger as close as possible to the bin, or other storage structure (**move auger slowly towards the bin with the towing vehicle - not by hand**).
2. **For 82' Models:** These models are equipped with an extendable/collapsible axle. **The axles must be collapsed for transporting.** After the auger is positioned at the bin site, and before raising the auger, the axles **must** be extended.

**IMPORTANT!** Auger must be in the full down position and attached to the towing vehicle before extending the axles. A hydraulic jack with a minimum 5 ton (4536 kg) rating is recommended.

 **CAUTION!** When raising the auger axle, *Do Not* rely solely on hydraulic or mechanical jacks for support. Use appropriate jack stands or equivalent for supporting the unit.

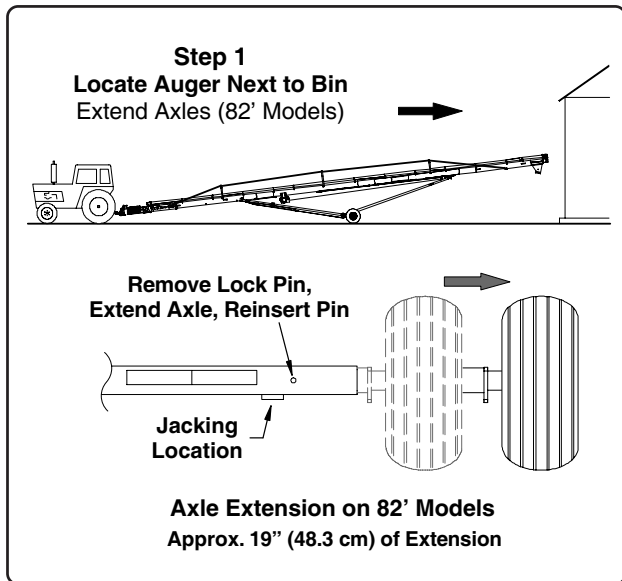

Fig. 2

3. Raise one side of the undercarriage at a time to extend or collapse the axles. There is a collar welded to the bottom side on each end of the axle tube to prevent the jack from slipping off, position the jack below this collar.

Raise the axle just high enough for the tire to clear the ground. **Place jack stands or equivalent beneath the axle for support.**

Remove the lock pin securing the inner axle tube and extend the axle out aligning the next hole in the inner axle with the hole from which the lock pin was previously removed (the axle will extend approximately 19" [48.3 cm] to the next hole location). Reinsert lock pin.

Repeat this procedure on the opposite side of the auger. Reverse this procedure when collapsing the axles (See Fig. 3).

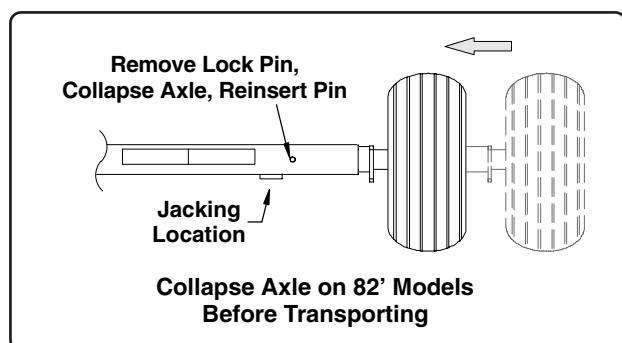
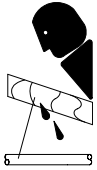

Fig. 3

## STEP 2: Raise Auger



**WARNING!** Hydraulic systems are highly pressurized. Do Not connect or disconnect hydraulic components when there is pressure in the system.



Escaping hydraulic oil, even an invisible pinhole leak, can penetrate body tissues and cause severe injury.

If injured by hydraulic oil escaping under pressure, see a doctor at once. Serious infection or reaction may occur if medical attention is not received immediately.

1. Connect the hydraulic hoses from the auger winch to the tractor and raise the discharge end of the auger high enough to clear the top of the bin. **Keep hands clear of the winch drum when winch is in operation.**

**Electric Drive Models:** Connect winch to power source and raise discharge end of auger high enough to clear the top of the bin.

**IMPORTANT!** Observe the cable as it is winding onto the winch drum. The cable should roll up on the drum evenly, avoid cable buildup on one side of the drum.

**Do Not** block or restrict the movement of the tires. The wheels must be allowed to roll freely as the auger is being raised.

2. Check to make sure the auger discharge spout remains high enough to clear the top of the bin.

## STEP 3: Back into Position

1. Back the auger slowly into working position with the towing vehicle. **Never move the auger by hand, always use a vehicle.**

**Do Not** attempt to increase auger height by positioning its wheels on lumber, blocks or any other means to raise its height.

2. Continue backing the auger until the discharge spout is directly over the bin opening (**when positioning the discharge over the bin opening, keep in mind that the discharge end will lower a few inches as the auger fills with grain.**)

**When discharging into a grain spreader, maintain at least 12" (30.5 cm) of space between the discharge and the spreader.**



**WARNING!** Never stand between the tractor and auger when hitching or unhitching, unless the controls are in neutral and the brakes are locked.

3. Position the hitch jack vertical to the ground. Raise the inlet end just high enough to remove the hitch weight from the tractor drawbar. Remove safety chain and tractor hitch pin.

If hydraulic hoses were attached for winch operation, make sure they are disconnected before moving the tractor from the area.

Electric Models: Disconnect the power source and secure electrical cords to auger so they cannot become damaged during auger operation.

**NOTE:** It is good practice to secure the discharge end of the auger to the bin or storage structure to prevent possible wind damage (remember to disconnect any tie-downs and/or anchors before moving the auger away from the bin).

4. Lower the inlet hopper to the ground and check discharge spout position. If necessary, reposition and/or lower auger so spout is directly above opening when intake is resting on the ground.
5. Chock the auger wheels to prevent the auger from rolling. Disconnect tractor from auger.
6. Make sure all safety guards are in place before beginning grain transfer operations.

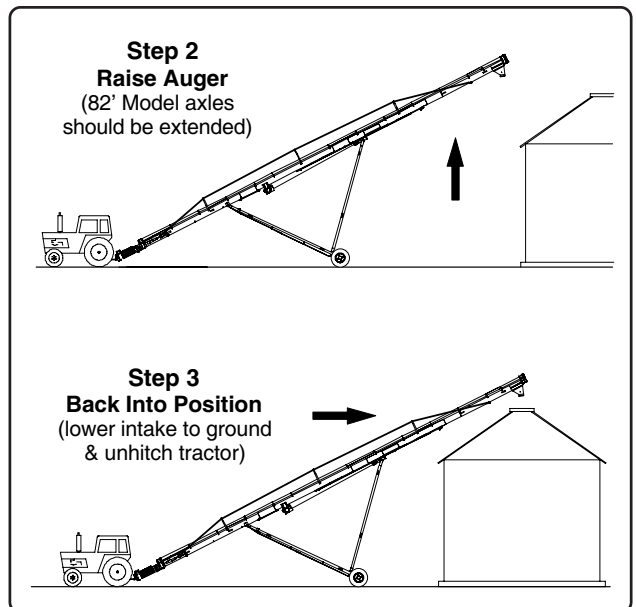

Fig. 4

# TRANSPORTING AUGER

## RELOCATION of AUGER

When grain conveying is completed, the auger should be moved away from the bin and lowered. It can then be moved to a different bin for more conveying operations, or it can be cleaned-up for storage.



**CAUTION!** Never stand between the tractor and auger when hitching or unhitching, unless all controls are in neutral and the brakes locked.



Never raise the intake end higher than necessary to attach to a towing vehicle. Weight is transferred rapidly to the discharge end when the intake is raised, especially when auger is in the raised position.

### STEP 1: Raise Auger

1. Empty all grain from the auger and clean up the work area.
2. Untie any anchors and/or supports that were used to help secure the conveyor.
3. Disconnect the PTO driveline and place driveline into the storage/transport bracket and secure for transport.
4. Using the hitch jack, raise the inlet end just high enough to attach the hitch to the tractor drawbar and install the safety chain (See Page 9 for safety chain information). Raise jack to transport position. Connect the hydraulic winch hoses to the tractor's hydraulic system.

**Electric Models:** Connect power source to winch.

5. Remove the wheel chocks and raise conveyor until the discharge spout clears the top of the bin.
6. Once auger is ready, move the auger slowly away from the grain bin with the towing vehicle. **Never attempt to move auger by hand, always use a vehicle.**

### STEP 2: Lower Auger

1. Immediately after the auger has cleared the bin or storage structure, lower the auger to its full down position.

**IMPORTANT!** Lower the auger to its full down position even if only relocating to another bin or storage structure.

### STEP 3: Move to Next Bin or Storage

1. Disconnect and secure the hydraulic winch hoses (or electrical power source) and secure hoses or electrical cords so they will not become damaged during transport.

**On 82' Models the axles will need to be collapsed before transporting the auger (See procedures for extending and collapsing the axles on Page 10).**

2. Move auger to next bin or storage site, or prepare the auger for storage (the auger should be stored in its full down position).
3. Follow the machine inspection recommendations on Page 6 before operating auger again.

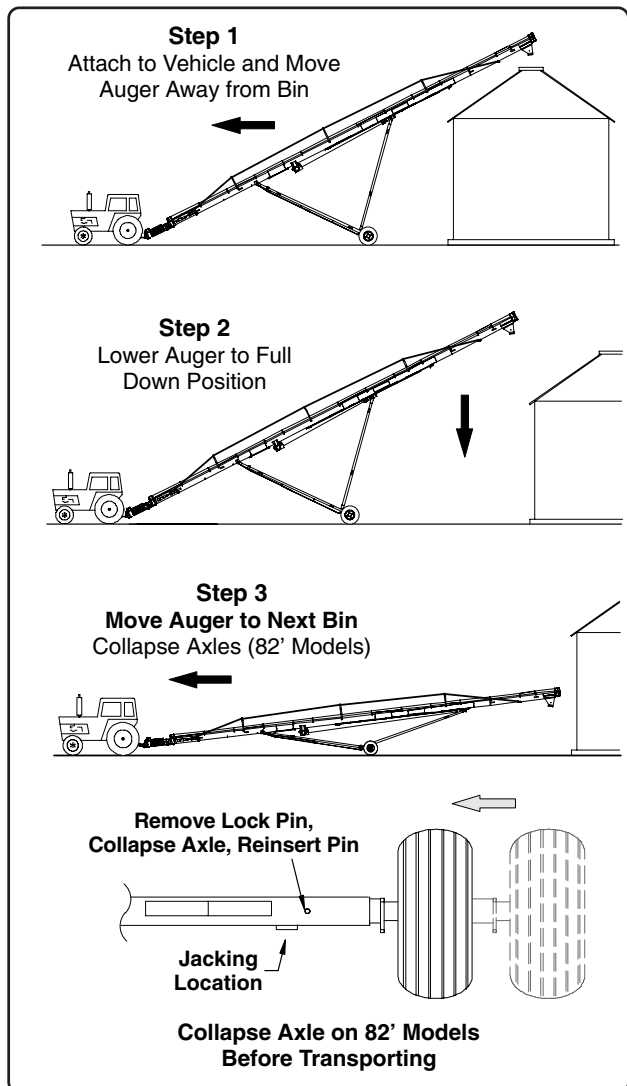
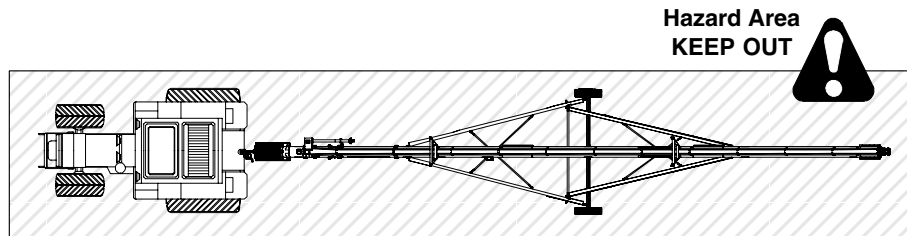

Fig. 5

## AUGER MOVING HAZARD AREA



**WARNING!** Before moving the conveyor, the operator should make sure all personnel are clear of the “Moving Hazard Area” as shown in the diagram below. Never allow persons to ride on the conveyor while it is being transported.



The shaded area represents the hazard area to stay clear of.

## TROUBLE SHOOTING

### **LOW CAPACITY**

- The auger may not be getting enough grain. Check to see that the intake screen has not bridged over restricting the flow.
- Auger speed is too slow.
- Grain is high in moisture. A low capacity will likely be achieved with high moisture grain. Excessive feeding of high moisture grain can cause plugging.

### **AUGER PLUGS**

- The auger may be getting too much grain where it is “jamming” inside the housing. Adjust the feeding of the auger to allow less grain to enter while maintaining full speed.
- Is the auger free of any foreign material such as, tarp corners etc. A plug at the discharge end will cause an auger to plug.
- Frequent starts under load. Allow auger to clean out before shutting down.

### **EXCESSIVE CONVEYOR NOISE**

- Damage may have occurred to the auger flight, thus causing the noise. Damage usually occurs because of foreign material having been run through the auger. It may be necessary to remove the flight for inspection.

### **AUGER LOWERING BY ITSELF**

- Check all hydraulic fittings, hoses and connections for leaks.

### **AUGER WILL NOT RAISE OR LOWER**

#### **Hydraulic Winch**

- See if the hydraulic coupler is properly attached to the tractor and the tractor reservoir is full of oil. The tractor pressure may be too low.
- A hydraulic pressure by-pass valve is located on the hydraulic motor on the winch. If the auger is full of grain and will not raise, the hydraulic pressure required to raise the auger may exceed the limit of the valve.

#### **Electric Winch**

- Make sure power source is connected and motor is wired correctly.
- Check cable making sure it is routed properly.
- Ensure belts are not slipping or damaged. Tighten or replace as necessary.
- Make sure sheaves and keys are properly installed.

# AUGER OPERATION

## DESIGNATED WORK AREA



**WARNING!** Under no circumstances should persons not involved in the operation be allowed to trespass into the work area.

It shall be the duty of all operator's to see that children and/or other persons stay out of the work areas. Trespassing into the work area by anyone not involved in the actual operation, or trespassing into a hazard area by anyone shall result in immediate shutdown by the operator.



It shall be the responsibility of the operator's to see that the work area has secure footing, is clean and free of all debris and tools which might cause accidental tripping and/or falling. It shall also be their responsibility to keep the work area clean and orderly during the operation.

Before starting the auger a designated work area should be established and properly marked. The following diagram shows the manufacturers designated work area for auger operation.

These areas shall be marked off with colored nylon or plastic rope or banners hung as portable barriers to define the designated work area.

All operators shall know how to shutdown and lockout the equipment in the event of an emergency. Refer to Pages 15 & 16 for shutdown and lockout procedures.

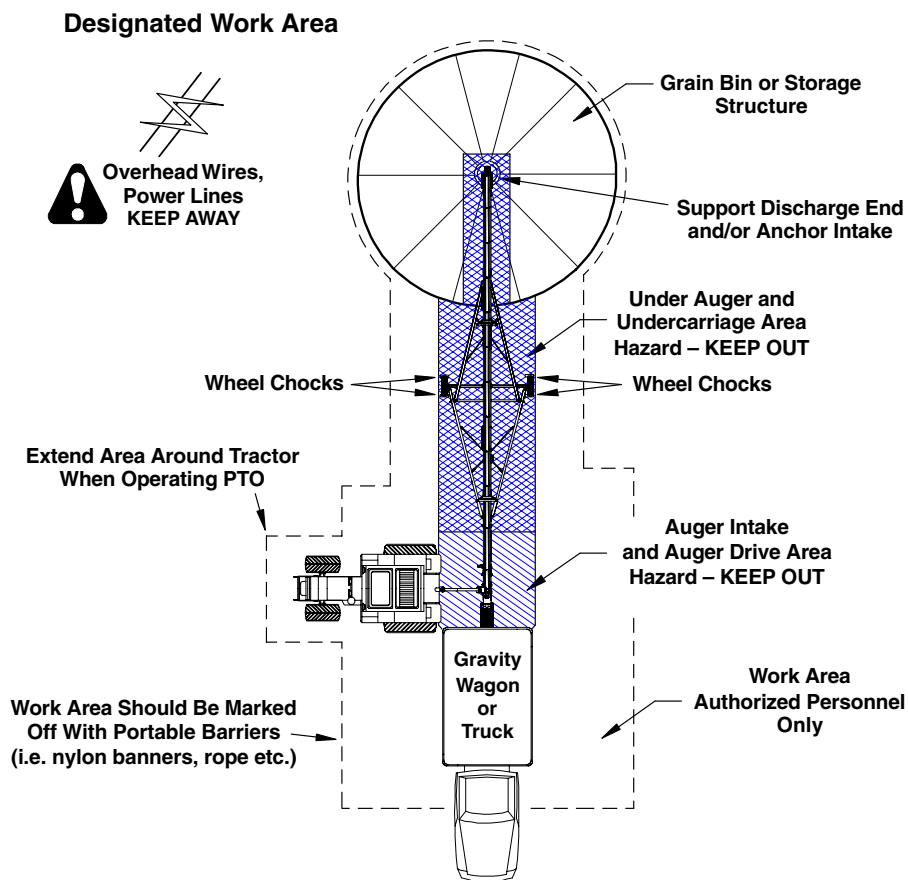



Be cautious of slippery surfaces. Make sure area is clear of tools, debris, or other items that may trip you or create a hazardous situation. When working in areas above ground, use appropriate fall protection equipment as set forth by OSHA guidelines and regulations.

## OPERATING PROCEDURES (ELECTRIC DRIVE MODELS)

 **WARNING!** The operator shall be aware of any unusual vibrations, noises and the loosening of any fasteners.  
Keep all safety shields and devices in place.

 Keep hands, feet and clothing away from moving parts.

 The operator shall have a full view of the auger work area and check that all personnel are clear of hazard areas before adding power.

 A main power disconnect switch that can be locked in only the “Off” position shall be provided. This shall be locked whenever work is being done to the auger.

 The reset and starting controls must be located so that the operator has full view of the entire operation.

 Disconnect power before resetting motor overloads. Make certain electric motor is grounded.

 Shut off power and lockout whenever cleaning or servicing the auger.

### Check the following before adding power:

- All safety devices are in place and properly fastened.
- Drive belts are properly tightened and in good condition. Replace belts if they are cracked, frayed, or damaged in anyway.
- Check electrical cords to ensure they are in good condition. Replace if necessary.
- Check electric power box and controls. Verify the power source can be locked out.
- Ensure auger is properly positioned and work area is appropriately marked and free of tools, debris and other hazards.
- Verify all drive component hardware and fasteners are tight, i.e. motor mount, pulleys, setscrews etc.

### Begin Grain Conveying Operations

1. Start the electric motor and check to make sure auger is running properly.
2. Slowly begin filling the intake end with grain until desired flow rate is achieved.

## ELECTRIC DRIVE SHUTDOWN/LOCKOUT

 **WARNING!** If the operator must leave the work area, or whenever servicing or adjusting, the auger must be stopped and the power source turned off and locked out.

 Precaution should be made to prevent anyone from operating the auger when the operator is away from the work area.

### Emergency Shutdown

Should the auger be immediately shutdown under load, **disconnect and lockout the power source.**

Clear as much grain from the intake area and auger as you can.

When as much grain as possible has been cleared from the intake area, reconnect the power source and clear the auger gradually.

**Never attempt to restart auger when full of grain. Starting the unit under load may result in damage to the auger, such damage is considered abuse and is not covered by warranty.**

### Normal Shutdown

Make certain that the intake area and the auger are empty before stopping the unit. **Before the operator leaves the work area, the power source shall be locked out** (See “Lockout” below).

### Intermittent Shutdown

When an auger is stopped and restarted under full load, it may result in damage to the auger and/or its components. Therefore if intermittent operation is to be carried out, it is advisable to reduce the load level. When kept from absolute filling, auger start-up is easier and operation more efficient.





### Lockout

The power source for electric units shall have a main disconnect box that can be locked only in the “Off” position.

**That’s what “shutdown and lockout” refers to; Shut off the main power source and lock the handle or breaker switch in the “Off” position.**

# AUGER OPERATION

## OPERATING PROCEDURES (PTO DRIVE MODELS)

	<p><b>WARNING!</b> The operator shall be aware of any unusual vibrations, noises and the loosening of any fasteners.</p> <p>Keep all safety shields and devices in place.</p>
	<p>Keep hands, feet and clothing away from moving parts.</p> <p>The operator shall have a full view of the auger work area and check that all personnel are clear of hazard areas before adding power.</p>
	<p>Shut off power and lockout whenever cleaning or servicing the auger.</p> <p>Before starting tractor, be certain power to the PTO is off. Be certain the PTO driveline is securely attached to the auger and tractor.</p>
	<p>Use a PTO with a rotating shield in good working condition that can be turned freely on the shaft.</p> <p>Stay out of designated hazard area of an operating PTO.</p>

### Check the following before adding power:

- All safety devices are in place and properly fastened.
- Make sure tractor is parallel to auger with PTO driveline as horizontal as possible.
- Ensure auger is properly positioned and work area is appropriately marked and free of tools, debris and other hazards.
- Verify all drive component hardware and fasteners are tight.

### Begin Grain Conveying Operations



The PTO drive models were designed for use with PTO's that provide up to 1000 rpm's.

1. Engage PTO at a slow RPM to minimize shock loads, then work up to recommended RPM. Make sure auger is running properly.

The auger can be operated at speeds from 900 to 1000 RPM's. **Do Not attempt full load operation at speeds below 900 RPM as high torque requirements may damage the auger.**

2. Slowly begin feeding inlet section with grain until desired flow rate is achieved.

## PTO DRIVE SHUTDOWN/LOCKOUT

	<p><b>WARNING!</b> If the operator must leave the work area, or whenever servicing or adjusting, the auger must be stopped and the power source turned off and locked out.</p>
	<p>Precaution should be made to prevent anyone from operating the auger when the operator is away from the work area.</p>

### Emergency Shutdown

Should the auger be immediately shutdown under load, **disconnect and lockout the power source.**

Clear as much grain from the inlet section and auger as you can. When as much grain as possible has been cleared, reconnect the power source and clear the auger gradually.

**Never attempt to restart auger when full of grain. Starting the unit under load may result in damage to the auger, such damage is considered abuse and is not covered by warranty.**

### Normal Shutdown

Make certain that the intake screen and auger are empty **before** stopping the unit. **Before the operator leaves the work area, the power source shall be locked out** (See "Lockout" below).

### Intermittent Shutdown

When an auger is stopped and restarted under full load, it may result in damage to the motor or auger. Therefore, if intermittent operation is to be carried out, it is advisable to reduce the load level.

When kept from absolute filling, auger start-up is easier and operation more efficient.

### Lockout

Stop PTO and turn off power source. Remove ignition key from power source (if this is not possible, remove the PTO driveline from the work area).

## GENERAL MAINTENANCE INFORMATION



**WARNING!** Shut off power and lockout before attempting to adjust, service, clean or repair the auger or any of its components.

Keep hands, feet and clothing away from moving parts.



Make sure all safety devices, shields and guards are in place and functional. Immediately replace any that are damaged or missing.

Never rely solely on mechanical or hydraulic jacks for support. Use jack stands or equivalent for support.



Never operate the auger with access doors or panels open.



**WARNING!** Hydraulic systems are highly pressurized. Do Not connect or disconnect hydraulic components when there is pressure within the system.

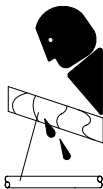

Escaping hydraulic oil, even an invisible pin hole leak can penetrate body tissues and cause serious injury.

Use a piece of wood or cardboard when searching for leaks, Never use your hands or other parts of your body.



If injured by hydraulic oil escaping under pressure, see a doctor immediately. Serious infection or reaction can occur if medical attention is not received at once.

For economical and efficient operation of your auger, maintain regular and correct lubrication, maintenance and service schedules. Neglect leads to reduced efficiency, excessive wear and needless down time.

Any parts needing replacement should be replaced with parts of the same type and size. **Do Not** modify or alter any of the auger components.

**NOTE:** It is recommended to apply an anti-seize compound to all shaft to coupler connections, all flight to flight connections, hub to axle spindles, PTO driveline to gearbox shaft, and all sheaves to motor shafts.

Applying anti-seize will make disassembly easier should any parts require replacement or repair.

## BEARING LUBRICATION INLET SCREEN BEARING

The intake screen has a bearing that supports the flight shaft. This bearing is fitted with a grease zerk (lubrication fitting) and should be lubricated after **every 50 hours of operation or once annually**.

**Use a multi-purpose type grease.**

Before greasing, make sure the zerk is free of dirt. Normally only one to two pumps of the grease gun is sufficient.

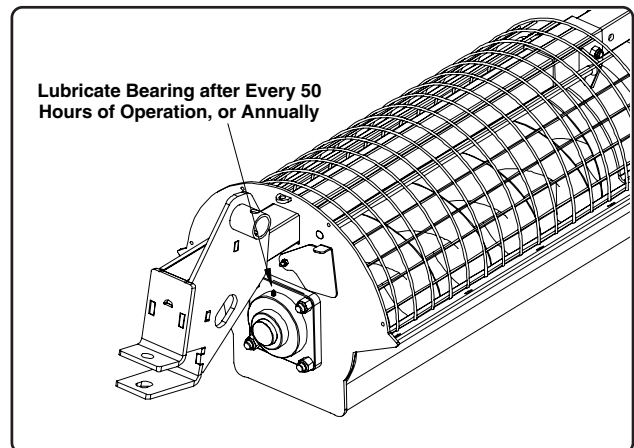

Fig. 6

## BEARING LUBRICATION DRIVESHAFT BALL BEARINGS

The main driveshaft bearings are a self-aligning sealed bearing. They have been packed with grease at the factory and require no further lubrication.

There is no adjustment to be made to the bearing, but check to make sure it is firmly fastened. Also check that the setscrews securing the lock collar to the shaft are tight.

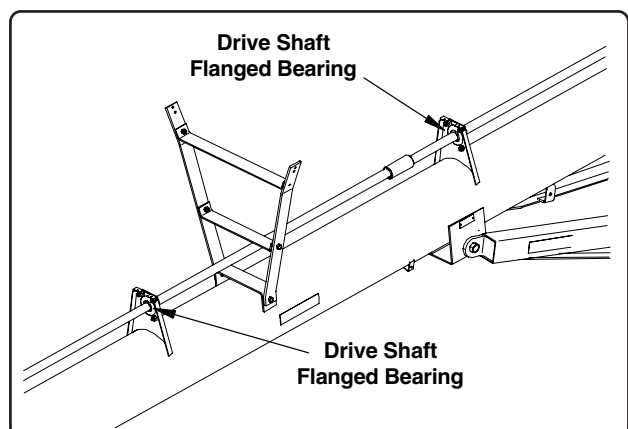

Fig. 7

# LUBRICATION & MAINTENANCE

## GUARDS

Check all guards to see that they are properly adjusted and securely fastened. This includes guards on the electric and hydraulic winch as well as electric drive components, drive shafts and head gearbox.

Also check to make sure the intake screen is in place and secure.

When properly adjusted, there should be no moving parts such as, drive belts, drive shafts, sheaves or the PTO driveline rubbing against the guards.

**Immediately replace any worn or damaged guards.**

## UNDERCARRIAGE AXLE BEARINGS



**WARNING! Do Not rely solely on hydraulic or mechanical jacks for support. Use jack stands or equivalent to support undercarriage axle.**

Tapered roller bearings are standard on all auger axles and should be **repacked with grease annually, or as needed determined by usage.**

**Use an anti-seize compound on the hub to axle spindle connection.**

### **To Repack Wheel Bearings:**

1. Raise the undercarriage axle high enough to allow the tire to clear the ground (**only raise one side of the axle at a time**).

**Place jack stands or equivalent beneath the axle for support and remove the tire.**

2. Remove the dust cover by prying around the edges, (See Fig. 8) then remove the cotter pin, slotted nut and flat washer from the end of the axle shaft.

3. Carefully remove the hub from the shaft being careful so the outer bearing doesn't fall to the ground. Clean the bearing with solvent and inspect the bearing for wear and damage, replace if necessary.

To inspect the inner bearing you will need to remove the seal from the rear of the hub (the seal may become damaged during this procedure, replace as necessary).

With the seal removed, you can now remove the inner bearing from the hub. Clean the bearing with solvent and inspect it for wear and damage. Replace if necessary.

4. Clean the hub cavity with solvent before reassembly. Using a good **automotive type axle grease**, repack the inner bearing. Insert the inner bearing into the hub and press on the grease seal.

5. Reinstall the hub onto the axle shaft being careful not to damage the lip of the seal during installation.
6. Repack the outer bearing. Fill the hub cavity with grease until about 1/3 full, then install the outer bearing.
7. Reinstall the flat washer and the slotted nut. Tighten the nut to seat the bearings. Keep tightening the slotted nut until the hub begins to bind as it is being rotated. Back off the slotted nut to the next slot and install a new 5/32" x 1 3/4" cotter pin. Reinstall the dust cap and remount the tire.

Repeat this procedure on the opposite wheel hub.

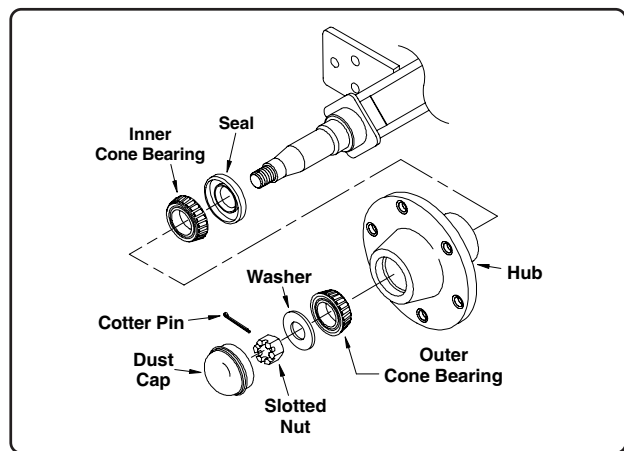

Fig. 8

## ELECTRIC DRIVE BELT ADJUSTMENT

All belts need to be checked and adjusted periodically to ensure all belt driven components are performing properly. Belt tension must be sufficient to avoid any slipping or abnormal wear during auger operation.

Check to see that correct alignment of the sheaves is maintained. Check that all sheaves are secured to their shaft, drive key is in place and setscrews are tight.

1. Note the two 3/4" nuts securing the threaded rods to the motor mount plate (See Fig. 9). Adjust these nuts to obtain proper belt tension. Make sure to adjust the nuts equally to keep the motor and drive sheaves properly aligned. **Do Not overtighten.**

Proper belt tension is approx. 9/16" (14 mm) of deflection per belt when using 7.50 lbs. of force at the center of the span between the two sheaves.

After 24 hours of operation, and for the remainder of belt life, deflection should be 9/16" (14 mm) using 4 to 4.50 lbs. of force. If you do not have a weight set to apply recommended amount of force, a fish scale is a good alternative.

## Electric Belt Drive Adjustment (con't.)

Tension can also be checked by pressing firmly on the belts at the center of the span between the two sheaves.

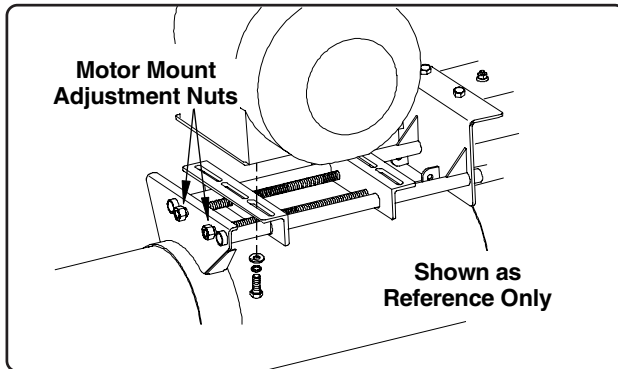



Fig. 9

**Do Not overtighten the belts.** Overtightening creates high stress on the belts and auger components and can result in damage to the belts and/or auger.

## HYDRAULIC COMPONENTS

The hydraulic components received with your Top Drive auger were selected to deliver the most efficient and economical use during operation.

Any parts used for replacement should be parts of the same type and size as the original.

 **WARNING!** Hydraulic systems are highly pressurized. Do Not connect or disconnect hydraulic components when there is pressure within the system.

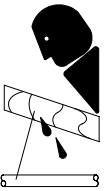
 Escaping hydraulic oil, even an invisible pin hole leak can penetrate body tissues and cause serious injury. Use a piece of wood or cardboard when searching for leaks, Never use your hands or other parts of your body.

 If injured by hydraulic oil escaping under pressure, see a doctor immediately. Serious infection or reaction can occur if medical attention is not received at once.

- Allow hoses to coil in their original shape. Avoid pinching, crimping or twisting the hoses that would otherwise restrict the flow of the hydraulic system.

**IMPORTANT!** Keep hydraulic hoses away from moving parts. Make sure to secure the hoses in a manner that they cannot become damaged when transporting the auger.

- Check hoses, fittings and connectors for leaks. Repair or replace as necessary.
- When not in use, make sure the fittings on the end of the hoses are protected from dirt and other contaminants.
- The fittings required for attaching the hoses to the tractor are not furnished. **Two (2) 1/2" NPT female fittings are needed for attaching the tractor fittings to the hose ends.**

## Hydraulic Operated Winch

The winch is shipped with oil already installed.

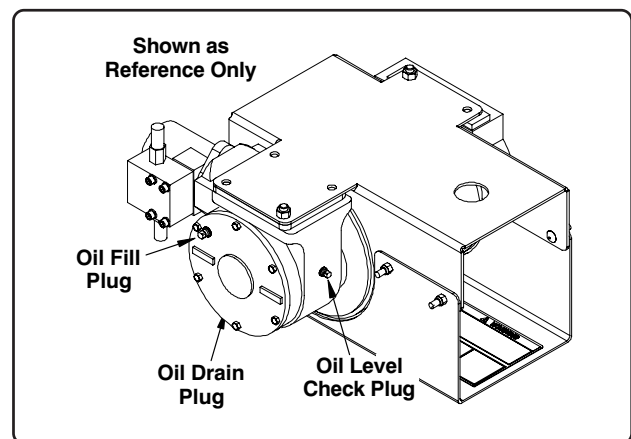

Fig. 10

Refer to the following instructions for adding oil when the winch is mounted onto the auger.

1. Place the auger in as horizontal position as possible (auger will need to be in the full down position and as level as possible for an accurate reading).
2. Remove the level check plug from the winch gearbox (the plug is located on the opposite side from the relief valve, See Fig. 10). Oil should begin to leak from the opening. If it does, oil level is sufficient, reinstall plug.

If additional oil is needed, Use a syringe type device, and add oil. Remove the level check plug and the fill plug on the face of the gearbox. Add oil until it begins to flow out of the level check plug opening. Reinstall plugs. **Do Not overfill. Too much oil may damage the seals.**

When additional oil is required, we recommend the use of an **SAE 85W140** non-foaming multipurpose gear oil. **Capacity: 8 oz. (.24 L).**

Use a grade/brand that is commercially available for automotive differentials. Extra pressure additives may be of some value in severe applications.

# LUBRICATION & MAINTENANCE

## ELECTRIC WINCH



**WARNING!** Shut off power and lockout power source before attempting to adjust, service, clean or repair the winch or any of its components.



A main power disconnect switch capable of being locked only in the "Off" position shall be used. This shall be locked whenever work is being done to the equipment.

The winch is shipped with oil already installed. Even under normal operating conditions, oil still has the tendency to dissipate. Periodically check oil level and maintain proper oil level.

### Check Oil Level:

1. Place the auger in as horizontal position as possible (auger will need to be in the full down position and as level as possible for an accurate reading).
2. Remove the plug from the side of the gearbox as shown in Fig. 11, oil should begin to leak from the opening. If it does, oil level is sufficient, reinstall plug.

If additional oil is needed, remove the vent/fill plug from the top of the gearbox. Add oil until it begins to flow out of the level check plug opening. Reinstall both plugs. **Do Not overfill. Too much oil may damage the seals.**

When additional oil is required, we recommend the use of an **SAE 85W140** non-foaming multipurpose gear oil. **Capacity: 46 oz. (1.36 L).**

Use a grade/brand that is commercially available for automotive differentials. Extra pressure additives may be of some value in severe applications.

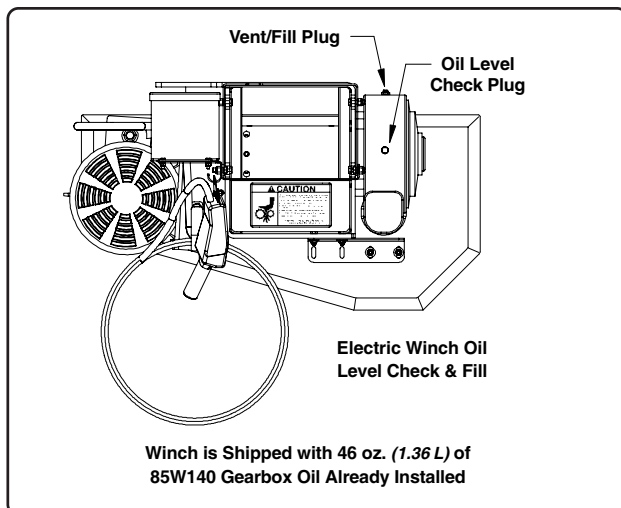

Fig. 11

### Electric Winch Belt Adjustment:

1. Check belts for fraying, cracking, or other damage. Replace as necessary.
2. Check belts for proper tension. Belts should deflect approximately 1/2" (13 mm) when firmly pressed in the center of the span between the two sheaves.
3. To adjust belt tension, loosen the four bolts securing the motor mount plate, two bolts at top and two bolts at bottom (one of the top bolts is also used to secure the belt guard bracket as shown in Fig. 12). Using a pry bar, piece of wood or similar object, pry the motor mount plate out to achieve proper belt tension (the pry bar can be inserted from the bottom side of the motor mount plate). After proper tension has been set, retighten all four bolts.

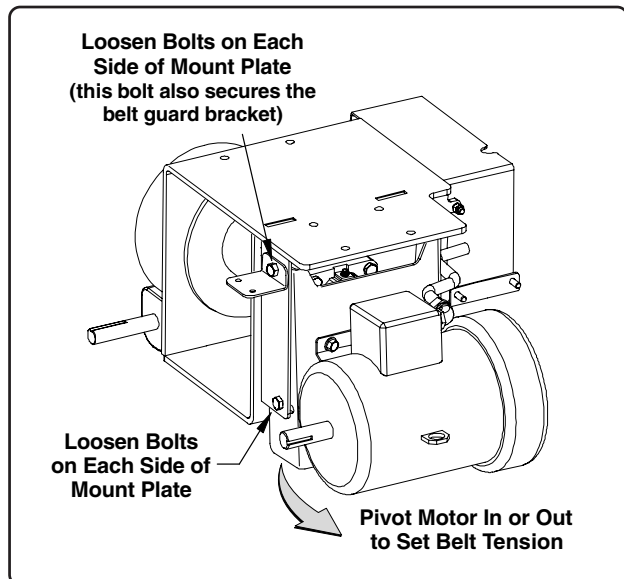

Fig. 12

### Electric Winch Operation

The winch is designed to be connected to a grounded **220 volt** electrical power system.

**A main power disconnect switch capable of being locked only in the "Off" position shall be used.** This shall be **locked** whenever work is being done to the equipment and components.

**Electric motors and controls shall be installed by a qualified electrician and must meet the standards set by the National Electric Code and all local and state codes.**

The pendant control is used to operate the upward and downward motions of the auger by depressing either of the buttons labeled "Forward" or "Reverse" on the hand-held pendant (See Fig. 13).

Electric Winch (con't.)

Electric Winch (con't.)

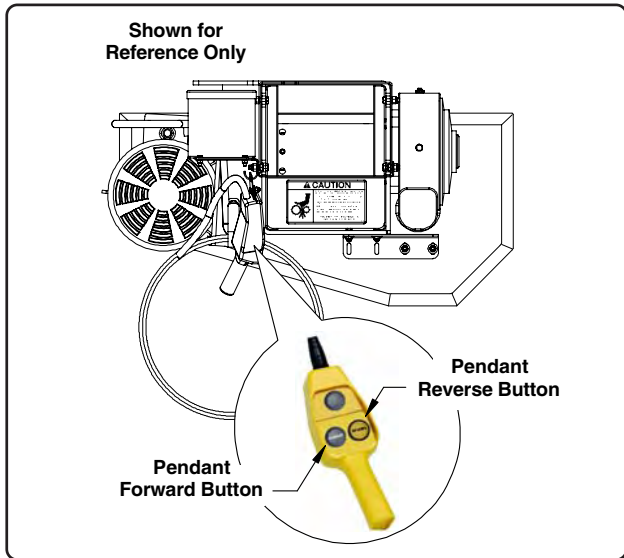



Fig. 13



**WARNING!** Shut off power and lockout power source before attempting to adjust, service, clean or repair the winch or any of its components.

If the winch operates in the opposite direction that is shown on the label, simply reverse the two wires that are located on the backpanel in the control box (See illustration below).

It is suggested to have a qualified electrician or a Hutchinson/Mayrath service tech perform the following procedure.

1. **Shut off and lockout the power source.** Remove the cover from the control panel box as shown in the illustration below.
2. Reverse the 2T1 & 4T2 wires as shown.

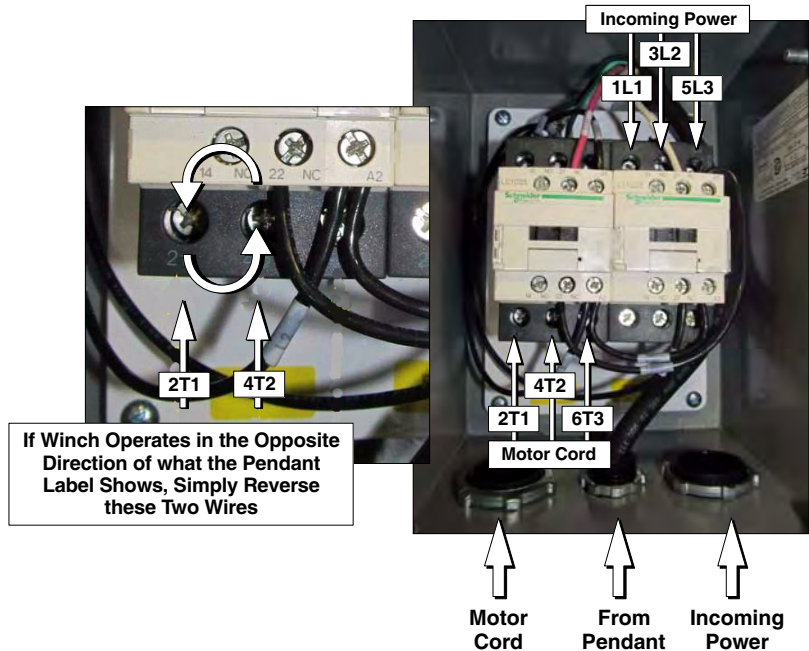
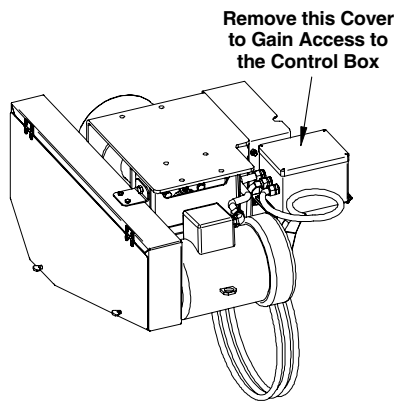

# LUBRICATION & MAINTENANCE

## **ELECTRIC WINCH BEARING**

The bearing on the electric winch is a self-aligning sealed bearing that has been lubricated at the factory.

Lubricate (1 pump) every **50 hours** of operating time using an SAE multi-purpose grease.

The bearing is located behind the motor mount plate as shown in Fig. 14. It is accessible from the bottom side of the motor.

The bearing itself requires no adjustment, but check regularly to ensure bolts, lock collar and setscrews are properly tightened.

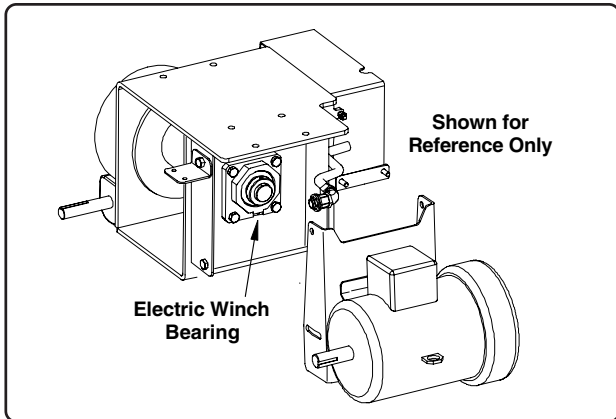

Fig. 14

## **ELECTRIC & PTO DRIVE GEARBOX**

**IMPORTANT! The gearbox is shipped WITHOUT oil. Oil *must* be added before operation.**

**Under normal working conditions oil will dissipate, even in an enclosed gearbox. Check oil in gearbox periodically and maintain proper level.**

Add **approx. 28 oz. (.83 L)** of **EP80W90** non-foaming multipurpose gear oil when used in normal operating temperatures between 40°F to 120°F (4.4°C to 48.9°C).

Use a grade/brand that is commercially available for automotive differentials. Extra pressure additives may be of some value in severe applications.

For temperatures below 40° (4.4°C) an EP 80W oil is recommended.

The oil level should be checked prior to the first time the auger is to be operated.

Check oil level by positioning the auger so the PTO gearbox is as level as possible (See Fig. 15). Remove the vented plug on top of the gearbox and visually inspect the oil level, or insert a dipstick into the opening and record the oil level. Whichever method is used, make sure to use the same procedure for future oil level checks (the auger should also be in the same position when future oil levels are taken).

## *Electric & PTO Drive Gearbox (con't.)*

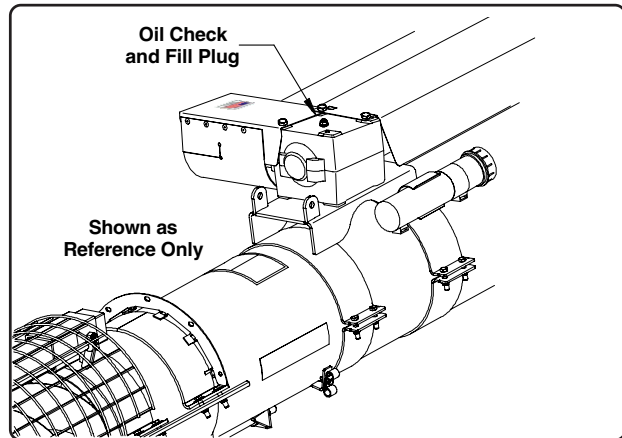

Fig. 15

## **PTO DRIVELINE LUBRICATION**



**WARNING! Before engaging PTO, be sure the PTO driveline shaft shield turns freely on shaft.**

**Keep hands and clothing away from the PTO components during operation.**

The PTO driveline has three (3) fittings that require lubrication (See illustration on Page 23).

Lubricate all fittings with a good quality lithium based EP grease which meets NLGI No. 2 Specifications and contains no more than 1 percent molybdenum disulfide (example: Shell Super Duty or equivalent).

An EP grease meeting the NLGI No. 2 Specifications and containing 3 percent molybdenum disulfide **may be substituted in the telescoping members only** example: Mobil Oil Co. (Mobil Grease CMP); Shell Oil (Retinax AM); & Texaco (Molyex EP No. 0 & No. 2).

**Telescoping members should be lubricated while in the collapsed position.**

- The first lube interval should be **16 to 24 hours after initial start-up and operation, then follow the recommendations shown on Page 23.**
- Check the u-joint setscrews at the auger end to make sure they are tight against the auger drive shaft.

### ***Replacement Parts are Not Lubricated***

Replacement parts must be lubricated at the time of assembly. Depending on the replacement part, use the chart on the following page (Page 23) to determine the proper amount of grease to use for that particular location. After repaired parts have been lubricated and installed, follow the recommendations in the chart for lubrication intervals.

## PTO DRIVELINE SHEAR BOLT

The PTO driveline is equipped with a shear bolt at the tractor connection. Extra shear bolts are provided and stored in the operator's manual container.

The shear bolt protects the auger from damage should the auger become plugged or subjected to high loads. If this scenario should occur, the shear bolt would "shear off" causing the connection to the auger to suddenly stop (the tractor's PTO would still continue turning, but not the auger driveline).

Immediately shut down the tractor and lockout before attempting to investigate the cause of the problem.

It is important that the correct replacement bolt be of the same size and strength as the original (see chart below). This is to insure the shear device will function properly to help protect the operator and the auger.

### PTO Driveline Lubrication Recommendations

After the first lube interval (first 16 to 24 hours of operation) the following schedule should be maintained.

Interval	Location	Amount
4 hrs.	U-Joint Cross & Bearing	1 Pump
8 hrs.	Telescoping Members	4-8 Pumps

### Shear Bolt Specifications

Auger Length	Shear Bolt Size	Shear Bolt Grade	Replacement Shear Bolt Kit
72'	3/8-16 x 1-1/4"	Grade 8	1018892
82'	3/8-16 x 1-1/4"	Grade 8	1018892

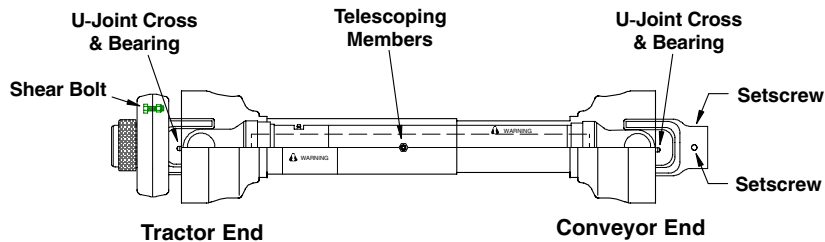

## HEAD GEARBOXES

**IMPORTANT! Gearboxes are shipped WITHOUT oil. Oil *must* be added before operation.**

**Under normal operating/working conditions, oil will dissipate, even in an enclosed gearbox. Check oil in gearbox periodically and maintain proper level.**

To check oil levels or add oil, position the auger so the gearboxes are as level as possible.

Remove the plug from the front side of the gearbox (See Fig. 16). Remove the vent plug from the top of the gearbox, this will be the oil fill location.

The vent openings are small, a syringe type tool is useful when adding oil. Add oil until it begins to flow from the opening on the front side of the gearbox. Reinstall both plugs making sure they are properly tightened to prevent leakage.

When additional oil is required, we recommend the use of an SAE 90W non-foaming multipurpose gear oil for normal operating temperatures between 40°F to 120°F (4.4°C to 48.9°C). For temperatures below 40° (4.4°C) use an SAE 80W oil.

Use a grade/brand that is commercially available for automotive differentials. Extra pressure additives may be of some value in severe applications.

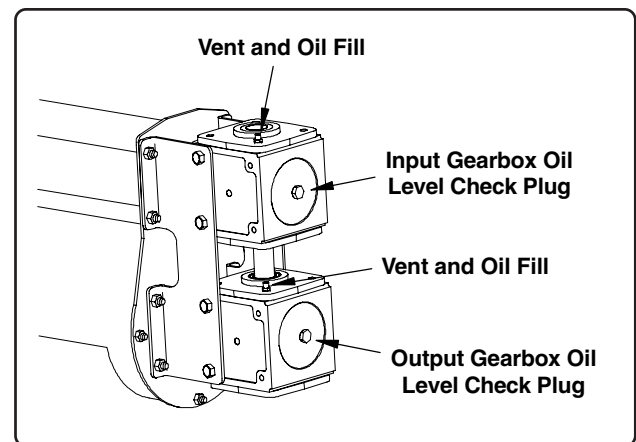

Fig. 16

# ASSEMBLY INSTRUCTIONS

## TUBE SECTION LAYOUT



**WARNING!** Do Not rely solely on hydraulic or mechanical jacks or the hoist for support. Always use jack stands or equivalent for support.



Keep hands, legs and other body parts out from under the auger when auger is being raised by the hoist or by any other means.



Some parts are heavy, use assistance with lifting and while assembling these parts.

Wear the proper personal protective gear (ie. safety glasses, ear protection, gloves, etc.).

Keep the assembly and work area clean and free of tools and objects which could cause unsafe situations.

Whenever reference is made to the left, right, front or rear of the auger, it is always determined when standing at the hitch (inlet) end looking towards the discharge end.

Choose an open level ground accessible to a chain hoist or other lifting devices where the auger may be laid out in full length.

It will be convenient for assembly if the sections are placed on stands or saw horses, this will also make assembly of the undercarriage easier as well.

Be sure the stands or saw horses can support the weight of the tube sections. A stand height of 36" tall is recommended.

**Before beginning assembly it is suggested to read through the assembly instructions in this manual and layout all items from the kits to ensure all parts are accounted for.**

This not only helps you become familiar with the parts and assembly procedures, but also makes you aware of what tools, equipment or materials you may need.

Tube sections are shipped with the flights in the tubes and the drive shafts installed. Both models also have two or three separate lengths of drive shafts that are shipped separately. These shafts will be installed when assembling the main drive components.

The tube section layouts for the PTO drive models are shown on Page 25, the tube section layouts for the electric drive models are shown on Page 26.

1. Lay out the tube sections and main auger components in their respective order as shown in the following illustrations (leave enough space in between the sections to slide on the connecting bands).

**NOTE:** The PTO drive models also have band-on bearing supports for the drive shaft. These bearing supports will be attached to the first tubing section and can be laid out with the components until assembled onto the unit.

When assembling the tube sections, begin assembly at the discharge end of the auger by installing the double gearbox. This will ensure the drive shafts are properly located.

# ASSEMBLY INSTRUCTIONS

## TUBE SECTION LAYOUT (con't.)

### PTO Drive Models

#### 72' Model, PTO Drive

The last two sections of drive shafts (1034818 & 1040030) are shipped separately and will be installed prior to the assembly of the PTO drive components.

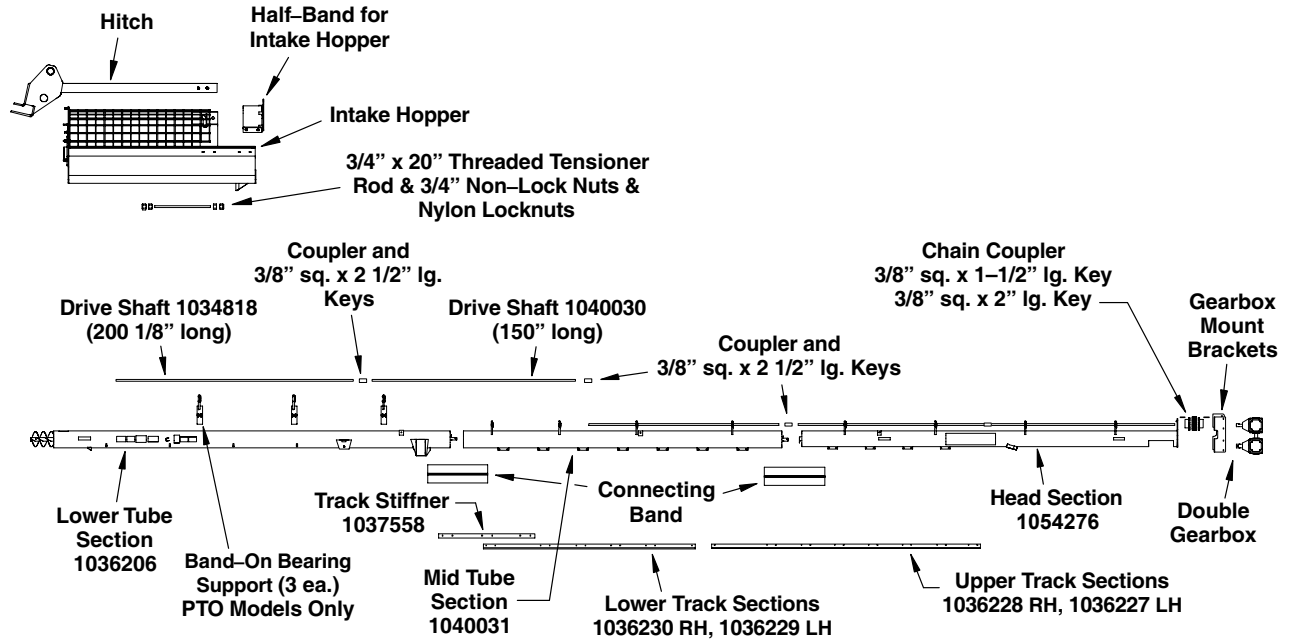

#### 82' Model, PTO Drive

The last three sections of drive shafts (1040030, 1040440 & 1040424) are shipped separately and will be installed prior to the assembly of the PTO drive components.

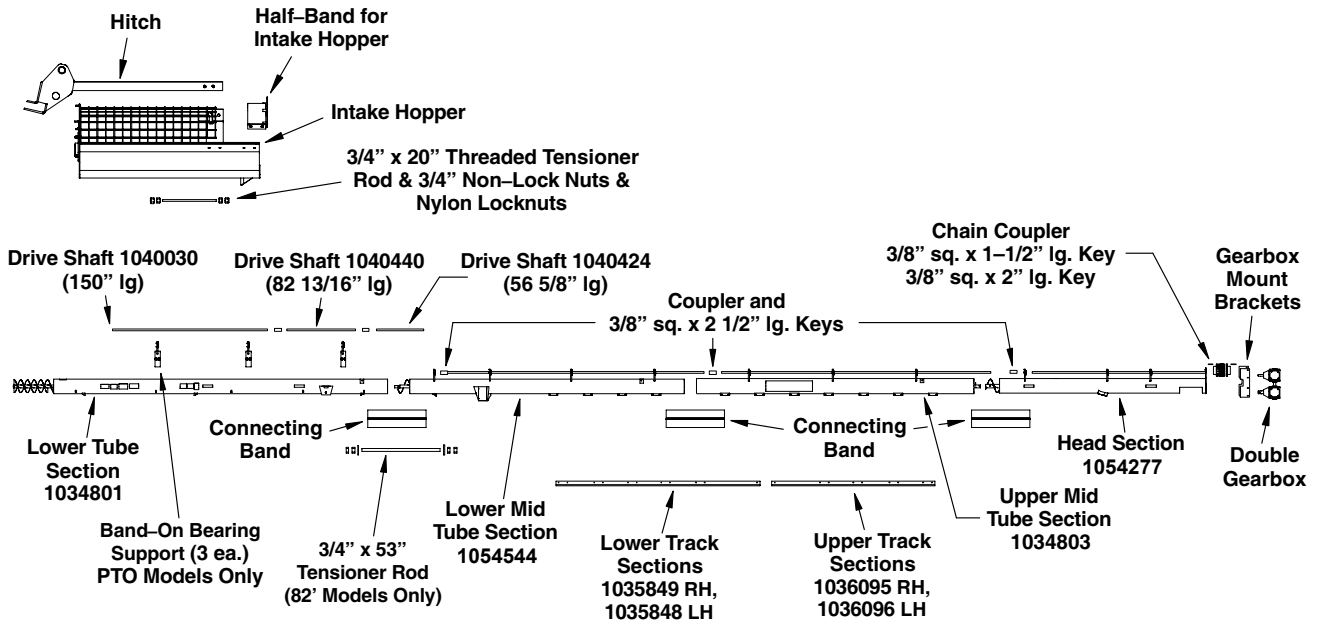

# ASSEMBLY INSTRUCTIONS

## TUBE SECTION LAYOUT (con't.)

### Electric Drive Models

#### 72' Model, Electric Drive

The last section of drive shaft (1040030) is shipped separately and will be installed prior to the assembly of the Electric drive components.

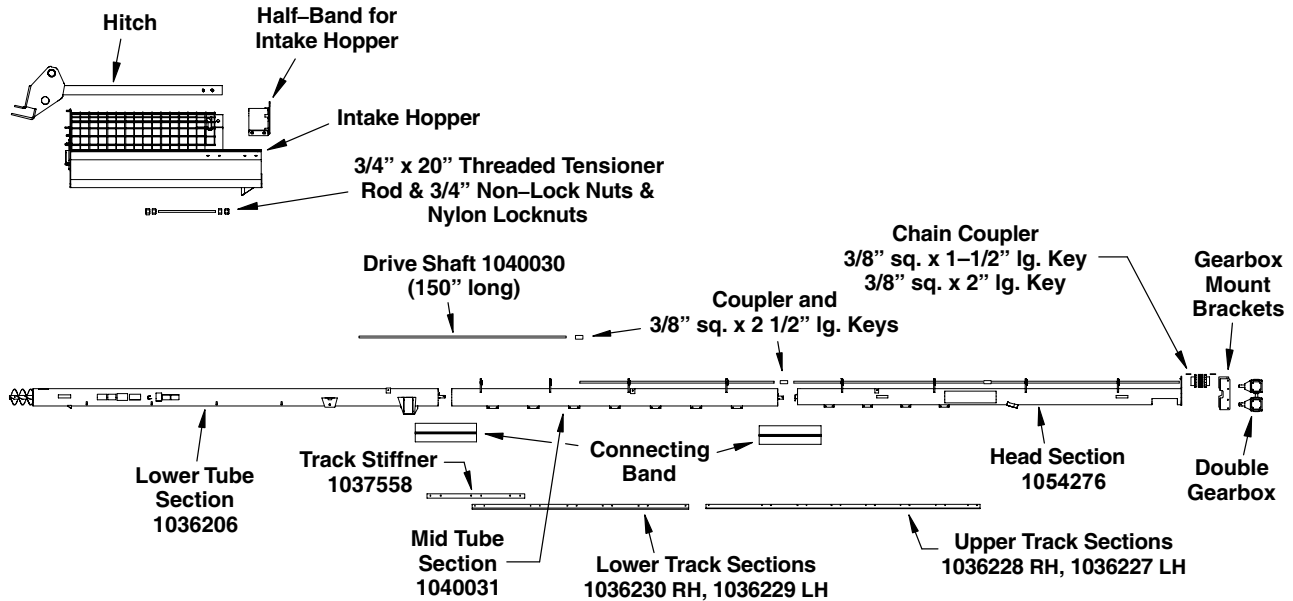

#### 82' Model, Electric Drive

The last section of drive shaft (1040424, 56 5/8" long) is shipped separately and will be installed prior to the assembly of the Electric drive components.

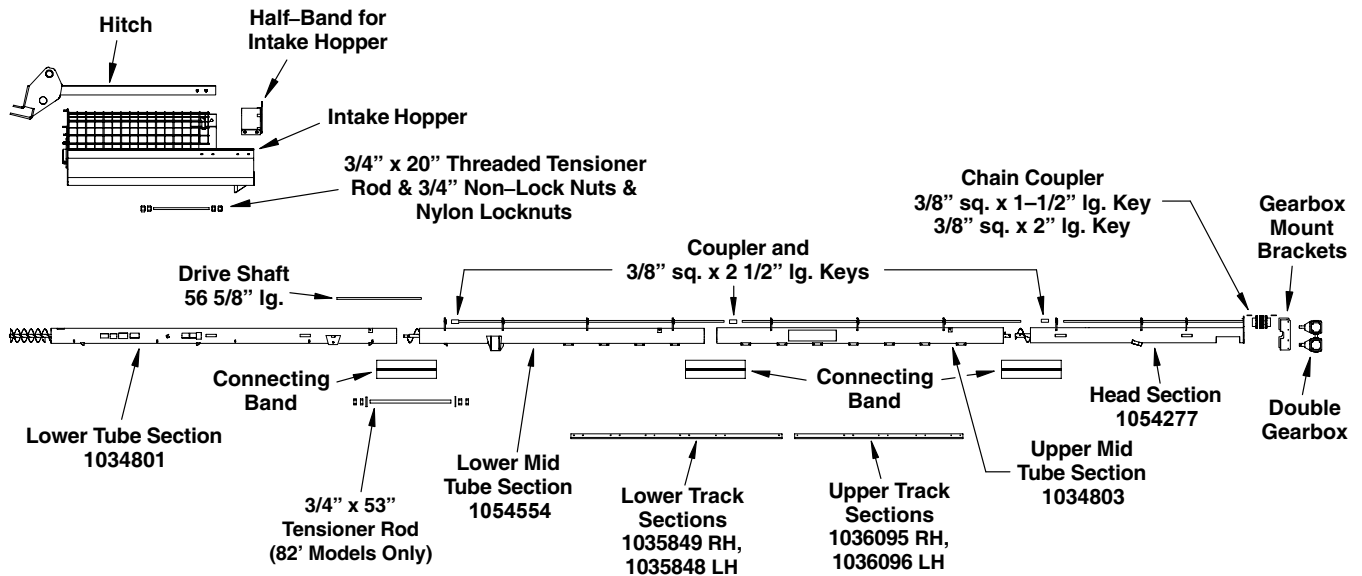

## 72' & 82' MODELS

### GEARBOX TO HEAD SECTION ASSEMBLY

**IMPORTANT!** The gearboxes are shipped WITHOUT oil. Oil *must* be added before operation. Refer to the "Lubrication & Maintenance" section.

1. Attach the gearbox mounting brackets to the head plate on the discharge end of the auger. Secure brackets using eight (8) 1/2" x 1 1/4" bolts and nylon locknuts (See illustration below). Do Not tighten completely, leave a little bit of movement for installing the gearboxes.
2. **Apply anti-seize compound to both the gearbox shafts and to the end of the drive shaft that will be connected to the chain coupler for the upper gearbox.**
  - Install a 3/8" x 1 1/2" key and chain coupler half onto the end of the drive shaft (temporarily position face of coupler half flush with the end of the shaft).
  - Install a 3/8" x 2" key and chain coupler half onto the shaft of the upper gearbox (temporarily position face of coupler half with end of shaft).
3. Position the upper and lower gearboxes in between the mounting brackets aligning lower gearbox shaft with the end of the auger flight. Slide the lower gearbox shaft into the end of the flight. Secure the gearboxes to the mounting brackets using 3/8" x 1-1/4" bolts, lock washers, flat washers and spacer bushings (do not tighten completely).
4. Secure the auger flight to the lower gearbox shaft using the 5/8" x 4" black bolts, flat washers, rubber washers and side-depress lock nuts (**only tighten enough to allow slight compression of the rubber washer, Do Not tighten completely to where the rubber washers become deformed**).
5. Install the head shaft cover using four (4) 1/2" x 3/4" bolts and lock washers. Tighten gearbox mounting hardware and head cover hardware.
6. Position the chain coupler halves so there is approximately 5/16" gap between the halves (try to keep the distance from the end of each shaft equal). Install chain coupler onto both coupler halves (**do not** install chain coupler so that it is tight against the coupler halves, allow chain coupler to move slightly). Secure coupler halves to each respective shaft.

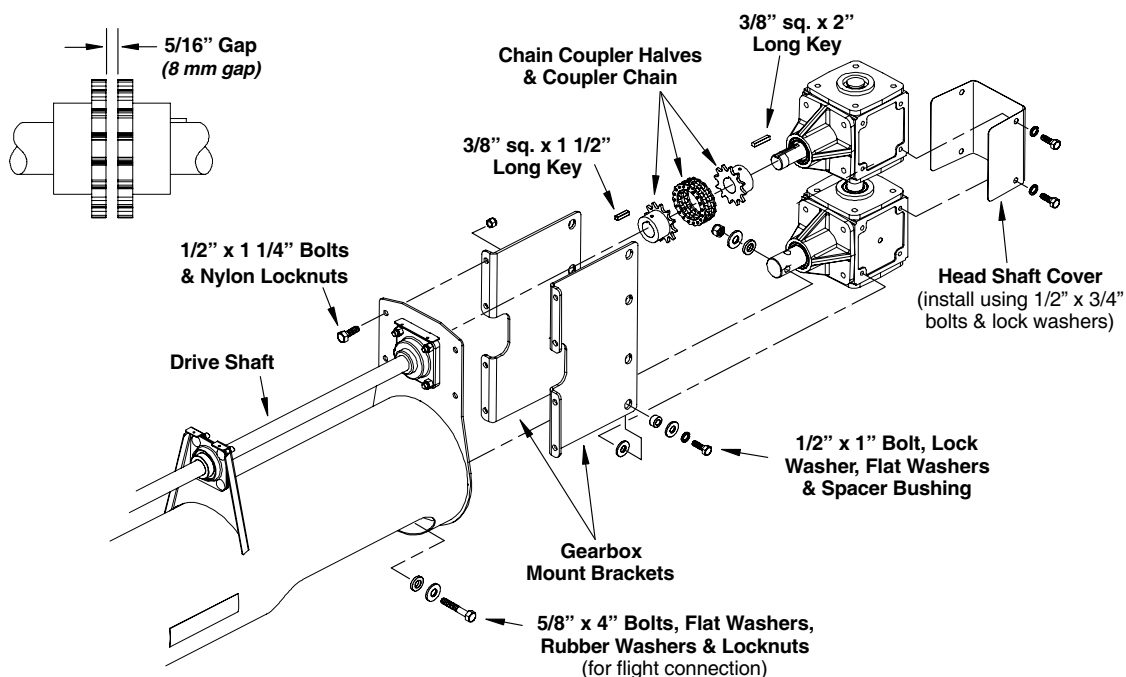

# ASSEMBLY INSTRUCTIONS

## AUGER HOUSING & FLIGHT ASSEMBLY

### 72' & 82' Models

1. Position the next tube section for installation. Leave enough space in between the tubing sections to allow the connecting band to be installed and to allow enough room to attach the flights together.

Remove the backing plates that are wired to the connecting bands. Slide a connecting band onto the discharge end of the next tubing section to be installed).

Note the flanges on the connecting bands. One of the flanges protrudes (overhangs) further than the other. Position the connecting band on the auger tube so the flange that overhangs the most is on top, See Fig. 17.

Install the backing plates using the 7/16" x 1 3/4" bolts and nylon locknuts provided. Do not tighten the hardware at this time.

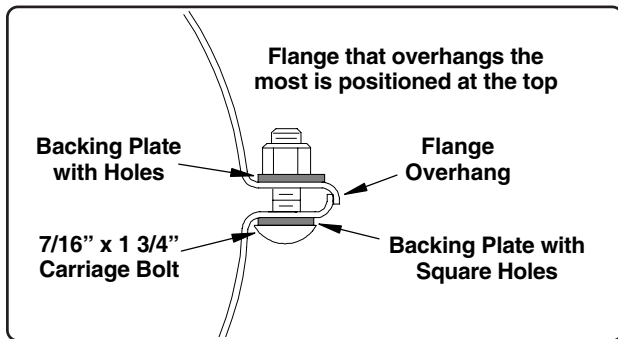

Fig. 17

2. Slide the flight from the mid section towards the head flight far enough to allow working room to connect the flights together.

Apply an anti-seize compound to the flight shaft and attach the flight from the mid section to the head section flight using two 5/8" x 4" black bolts and locknuts (the lower section of flighting will overlap the head section flight by approximately 1" as shown in Fig. 18).

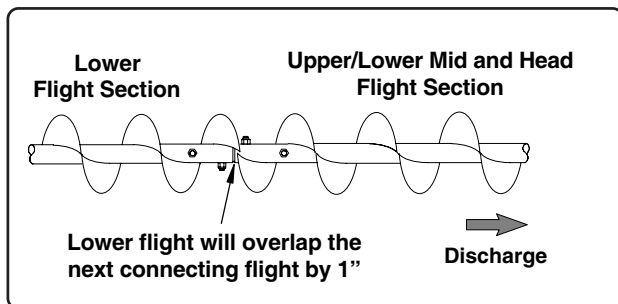

Fig. 18

3. Apply an anti-seize compound to the ends of the drive shafts. Install the 3/8" x 2 1/2" long keys into the keyways and slide a 1 1/2" I.D. x 1 1/2" I.D. coupler onto the end of the head section drive shaft. Slide the tubing sections together while inserting the lower drive shaft into the coupler and slide tubing sections together until they contact each other.

Slide the connecting band into position (connecting band should be halfway over each tube). Do Not tighten hardware at this time, it will be tightened after track sections have been installed.

4. When the drive shafts have been connected, there should be an 1/16" to 1/8" (2 mm to 3 mm) space in between the end of the shafts and the snap ring that is inside the coupler. If necessary, loosen the bearing locking collars on the drive shafts and position accordingly (See Fig. 19).

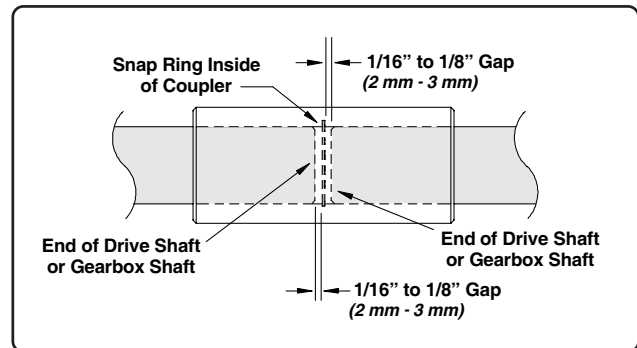

Fig. 19

5. Continue attaching the remaining tubes, drive shaft and flight sections in the same manner until all sections have been assembled.

## TRACK ASSEMBLY

1. Once all housing and flight sections have been assembled, verify the ends of the tubing sections are tight against each other and snug up the connecting bands (**the bands only need to be snugged up at this time , do not tighten them completely**). When snugging up the connecting bands, start with one of the middle bolts and work your way to one end, then start at the next middle bolt and work to the other end.

**NOTE: The tubing ends may not be completely square with each other, there may be a gap at the top and none at the bottom, or vice versa. As long as the tubing remains straight and in line, a small 1/16" to 1/8" gap is acceptable as long as some part of the tubes are making contact.**

**On the 72' Models only**, there will be a stiffener that will bolt to the first set of holes in the tracks and to the winch mount.

**NOTE: The winch mount pulley will need to be assembled to the winch mount prior to installing the stiffener. Refer to the track assembly instructions for the 72' models on Page 31.**

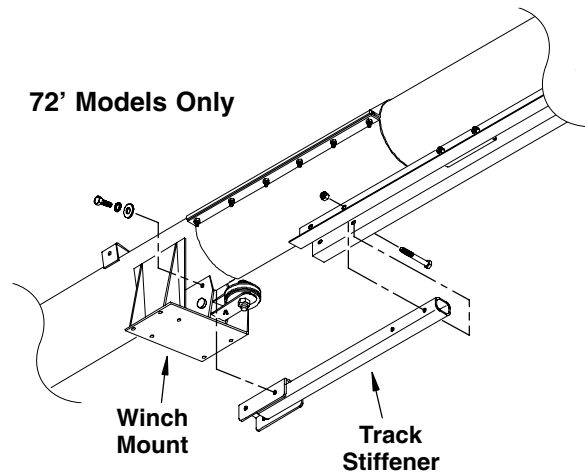

**On the 82' Models only**, there will be a 3/4" threaded tensioner rod that will help secure the first and second tubing sections together.

Insert the rod through the tensioning bracket located directly in front of the undercarriage mount bracket on the bottom side of the lower tube section and through the tensioning bracket on the second tube section. Install a 3/4" flat washer and two non-lock nuts onto each end of the rod. The rod will be tightened after the tracks have been installed.

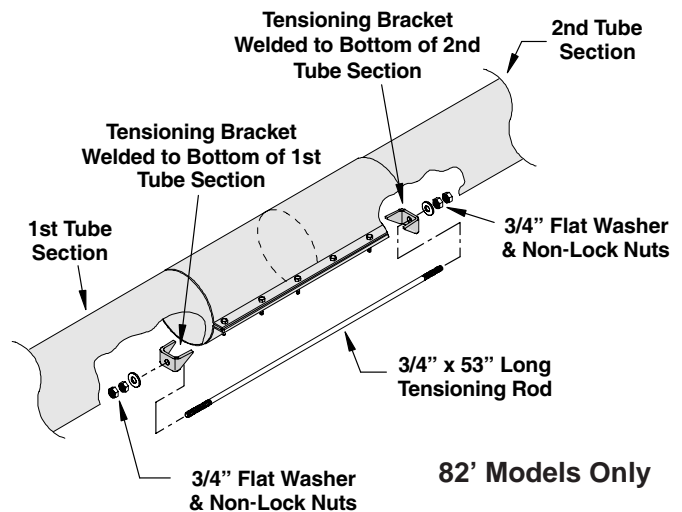

# ASSEMBLY INSTRUCTIONS

## TRACK ASSEMBLY (con't.)

When installing the track sections you will note that some of the track mounting holes will not have a mounting bracket on the housing in which to attach to. These areas will generally be located under the connecting bands, use the 2" long spacers in these locations (the spacers will be positioned between the tracks as shown in the illustration below).

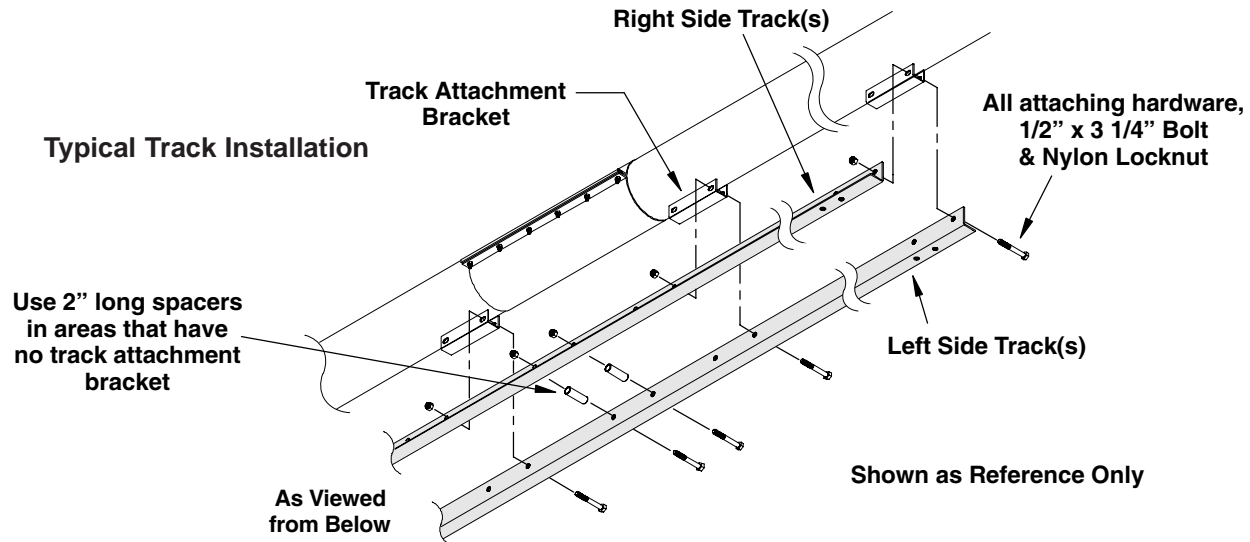

The tracks are 2" x 2" angle iron with predrilled mounting holes for attachment to the track mounting brackets and predrilled holes for mounting the upper and lower trolley stops. There is also a left hand and right hand set of tracks.

The set of four holes on the bottom of the tracks will be positioned at the discharge end of the auger (refer to the following illustrations on Pages 31 and 32).

**The left, right, front and rear of the auger are determined while standing at the inlet end and looking towards the discharge end.**

### Track Installation For All Models

Pages 31 and 32 show the appropriate track lengths and mounting locations for each model.

On augers that use more than one set of tracks you will note that one end of the track has only one mounting hole approximately 3" from the end, this end will abut with the next section of track which also has one hole 3" from its end.

1. Align the track mounting holes with the mounting brackets welded to the bottom side of the auger tubing. Secure the tracks to the mounting brackets using 1/2" x 3 1/4" bolts and nylon locknuts (use the 2" spacers in the locations that have no mounting brackets as shown in the illustration above, these locations are generally beneath the connecting bands).

Do Not tighten hardware at this time, for 72' Models, install the winch pulley and track stiffener as detailed on Page 31, then go to Step 2 on Page 32.

On 82' Models go to Step 2 on Page 32 and continue with track installation.

**TRACK ASSEMBLY (con't.)**

**Track Sections and Lengths**

**72' Models:**

- Left Lower Track - 123 11/16" long P.N. 1036229
- Right Lower Track - 123 11/16" long P.N. 1036230
- Left Upper Track - 240" long P.N. 1036227
- Right Upper Track - 240" long P.N. 1032628

**Install Winch Pulley (72' & 82' Models)**

On the **72' Models** a track stiffener will be installed and will attach to the lower section of tracks and to the winch mount. The winch mount pulley will need to be installed before the stiffener is bolted into place (see illustration to the right).

To install the winch pulley (both 72' & 82' Models), slide the shorter pulley clevis onto the anchor pipe on the winch mount plate as shown.

Stack the pulley, spacer bushing and washers as shown and install this assembly into the end of the clevis. Secure using one 1" x 3 1/2" bolt and nylon locknut. Install the 1/4" x 2 1/2" bolt and nylon locknut.

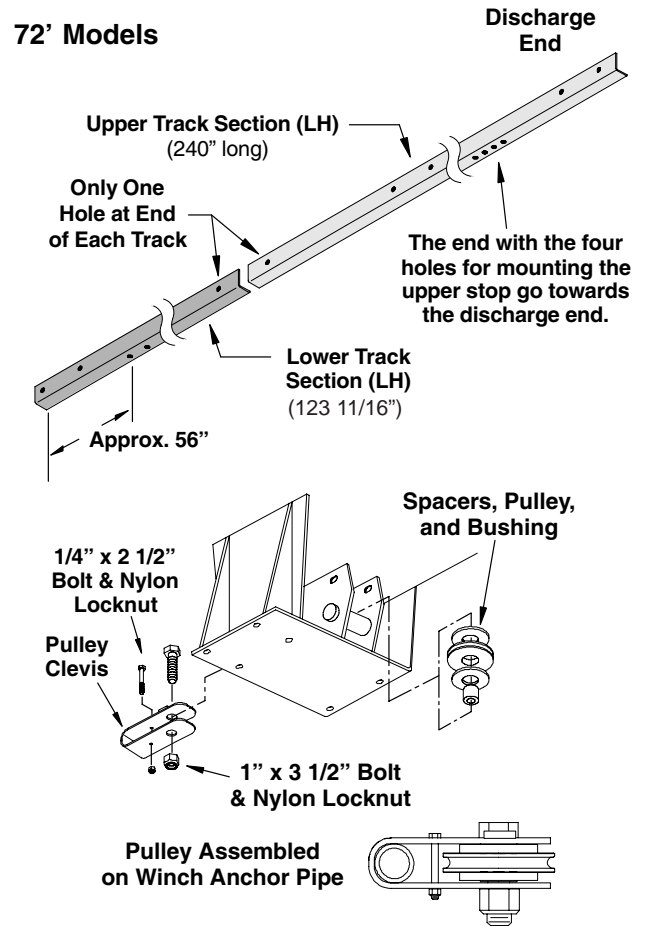

**Install Track Stiffener (72' Models Only)**

The first set of holes in the lower track sections will be used for mounting the track stiffener (these holes are located under the connecting band).

Position the saddle end of the track stiffener in between the winch pulley anchor mount plates as shown in the illustration to the right. The other end of the stiffener will be positioned between the tracks.

Secure the stiffener to the tracks using 1/2" x 3 1/4" bolts and nylon locknuts. Secure the saddle end to the anchor mount plates using four (4) 1/2" x 1" bolts, flat washers and lock washers (the mounting holes in the saddle of the stiffener are threaded). Tighten these four bolts and continue with the assembly instructions for the tracks beginning with Step 2 on the following page.

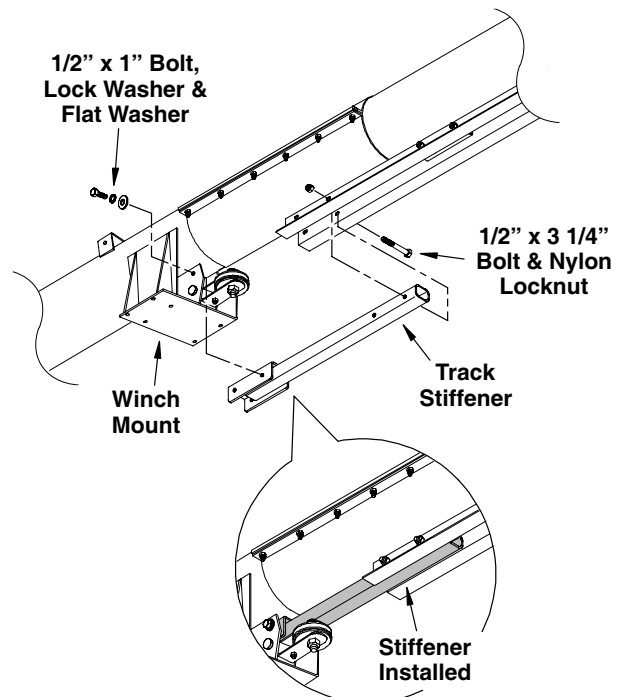

# ASSEMBLY INSTRUCTIONS

## TRACK ASSEMBLY (con't.)

### Track Sections and Lengths

#### 82' Models:

- Left Lower Track - 233" long P.N. 1035848
- Right Lower Track - 233" long P.N. 1035849
- Left Upper Track - 189" long P.N. 1036096
- Right Upper Track - 189" long P.N. 1036095

2. Snug up all the track bolts and verify the tracks are running straight (it may be necessary to loosen the connecting bands a little to help with alignment of the tracks).
3. Once tracks are properly in line, check to see that the tube ends beneath the connecting bands are still touching each other, then tighten all track hardware.

On 82' Models, tighten the 3/4" tensioning rod as detailed on Page 29. Tighten the nuts on each end equally. **Do Not** overtighten so it causes the top of the tubes to pull away from each other. Once properly secured, tighten the nuts against each other to lock them into place.

4. Check track alignment and tube ends once again and make any necessary adjustments.
5. Tighten the connecting band hardware. Tighten the bolts starting with one of the middle bolts and working to one end, then start again on the next middle bolt and tighten to the other end (See Fig. 20).

Repeat this process on each connecting band until all bolts are tight and the overhang on the flanges are tight together (See Fig. 21).

**IMPORTANT!** The overhangs on the flanges are meant to be tight against each other, but **Do Not** tighten so tight that the flanges are crushed and become deformed (See Fig. 21). **NOTE:** If it is impossible to get the connecting band tight on the auger tube without overly deforming the clamp, a new connecting band may be necessary.

The connecting band should be tight against the auger tube, flanges should be parallel to each other and all bolts evenly tightened.

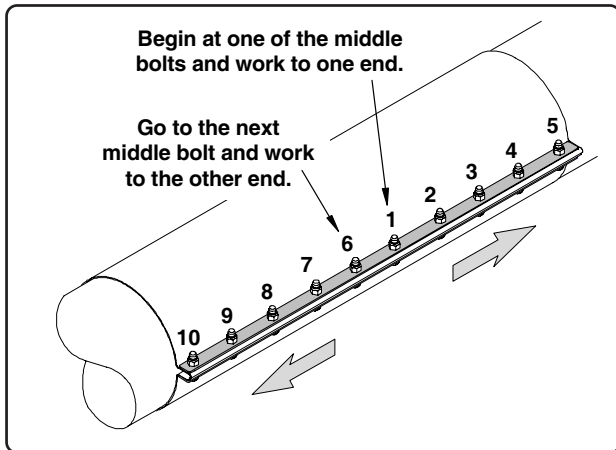
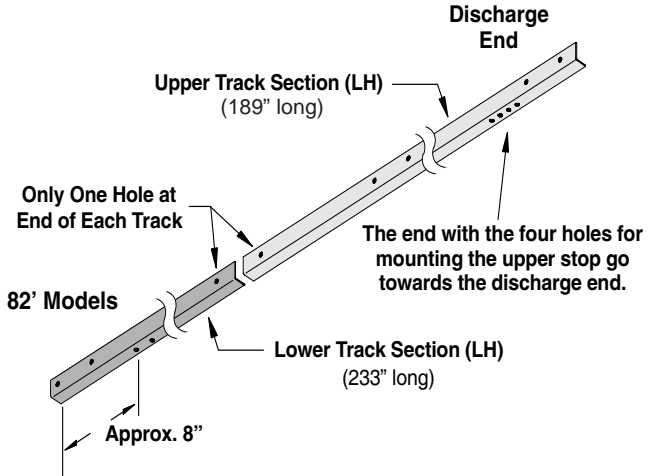

Fig. 20

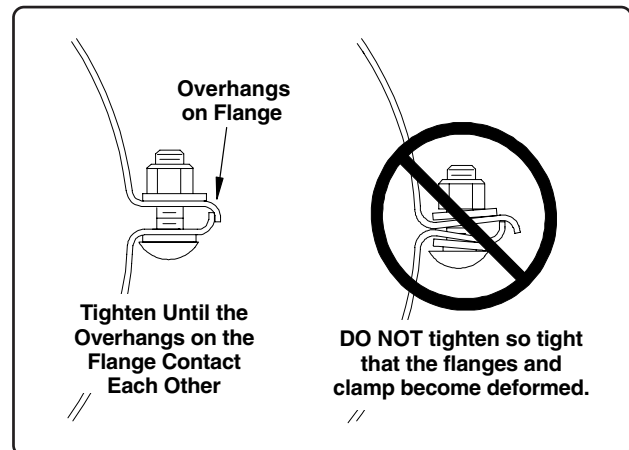

Fig. 21

## INTAKE SCREEN, HITCH & JACK ASSEMBLY



**CAUTION!** Some auger components are heavy. To avoid personal injury, use assistance when handling these parts.

1. Install the intake screen and hopper pan onto the inlet end of the auger. Insert the flight stub shaft through the bearing on the rear of the inlet hopper plate.

Install each half-band using, 3/8" x 1 3/4" bolts, flat washers and 3/8-16 nylon locknuts. **Loosely clamp the half-bands to the main auger tubing.**

2. Install a 3/4" **non-lock nut** onto each end of the 3/4" threaded tensioner rod and thread on far enough so the rod can be inserted through the bracket on the bottom of the main auger tube and the bracket on the bottom of the inlet hopper (See below).

Install a 3/4" **nylon locknut** onto each end of the tensioner rod. Tighten the locknuts on tensioner rod to achieve a 1/4" space between the bearing mount plate and end of flight shaft (see below). Tighten the non-lock nuts against the brackets.

3. Tighten the half-bands into position (make sure the inlet hopper remains square with the main auger housing).

**IMPORTANT!** When tightening the half-bands to the hopper pan, **DO NOT** tighten bolts so tight that they deform the hopper pan. Tighten bolts just tight enough until they start to distort the hopper pan, **Do Not** tighten beyond that point.

4. Once the inlet hopper is properly secured, insert the hitch tube through the opening on the rear panel of the hopper and into the mount tube at the front of the screen (See below).

Secure hitch tube using one 1/2" x 3-3/4" bolt and nylon locknut.

5. Install the jack assembly onto the mount tube located on the side of the hitch. Secure the jack using the attached locking pin.

6. If the small hitch tube cover is not installed onto the rear plate, use the 1/4" x 3/4" bolt and nylon locknut and secure it into place.

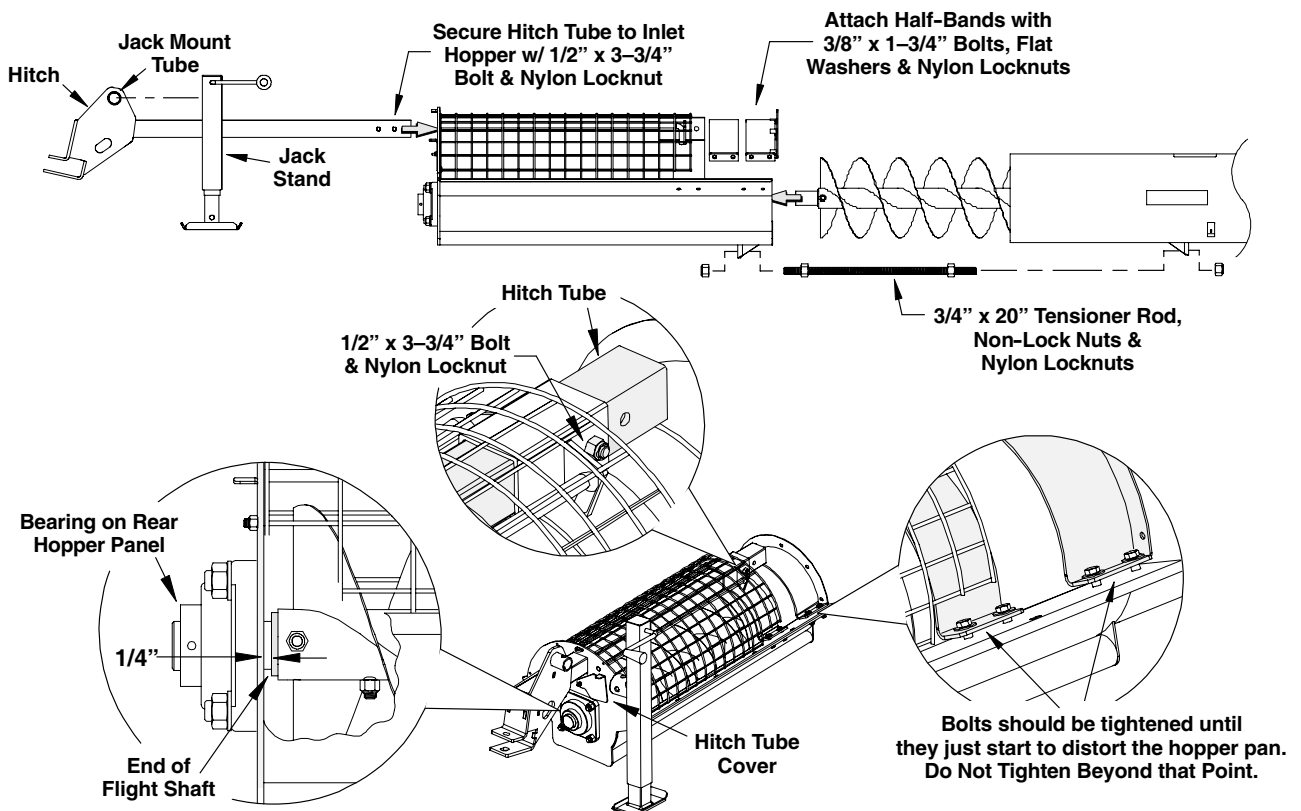

# ASSEMBLY INSTRUCTIONS

## DRIVE SHAFT & BAND-ON BEARING

### MOUNT INSTALLATION

#### (PTO DRIVE MODELS ONLY)

**NOTE:** PTO drive models use band-on bearing mounts at the inlet end along the first section of tubing. Refer to the following instructions when installing the band-on bearing supports.

#### 72' Models

- Slide the 150" long drive shaft through the first two bearing mounts that are welded to the second tube section (it may be necessary to loosen the lock collars on the bearing mounts).

Apply anti-seize compound to the end of the drive shaft and to the end of the existing drive shaft. Install two (2) 3/8" sq. x 2 1/2" long keys and the coupler to connect the drive shafts together. Leave a 1/16" to 1/8" gap between the ends of the drive shafts and the retaining ring located inside the coupler (See illustration on following page).

- Slide the upper portion of a band-on bearing mount onto the 150" drive shaft and allow the bearing mount to rest on the auger housing while supporting the shaft. Temporarily position a 73" (or 81 1/4") shaft cover so one set of mounting holes align with the first bearing mount welded to the housing. Position the band-on bearing mount so it aligns with the mounting holes on the other end of the cover.

Install the bottom half-band to the band-on bearing mount using four (4) 3/8" x 1 3/4" bolts and nylon locknuts. **Do Not tighten completely at this time.**

- Slide the upper portion of the last two (2) band-on bearing mounts onto the 200 1/8" long drive shaft spacing them in an approximate position as shown in the illustration below.

- Apply anti-seize compound to the ends of both the 150" and 200 1/8" drive shafts. Install a coupler and two (2) 3/8" sq. x 2 1/2" long keys to connect the drive shafts together. Leave a 1/16" to 1/8" gap between the ends of the drive shafts and the retaining ring located inside the coupler (See illustration on following page).

Locate the two band-on bearing mounts in the same manner as the previous one, using the shaft cover lengths shown below.

- Install the bottom half-bands using 3/8" x 1 3/4" bolts and nylon locknuts. **Do Not tighten completely at this time.** Align the drive shafts so they are in-line with the entire length of the existing drive shafts and then, tighten the half-bands to the band-on mounts. **(Shaft covers will be installed further in the assembly process, See Pages 44 & 45 and Page 60 for Internal Bearing sequence).**

- Tighten the lock collars on each of the bearing mounts to secure bearings to drive shafts. Check all lock collars down the continuous length of the auger to verify they are properly secured as well.

Drive Shaft Cover lengths for Models with the Internal Bearing Option are also shown below.

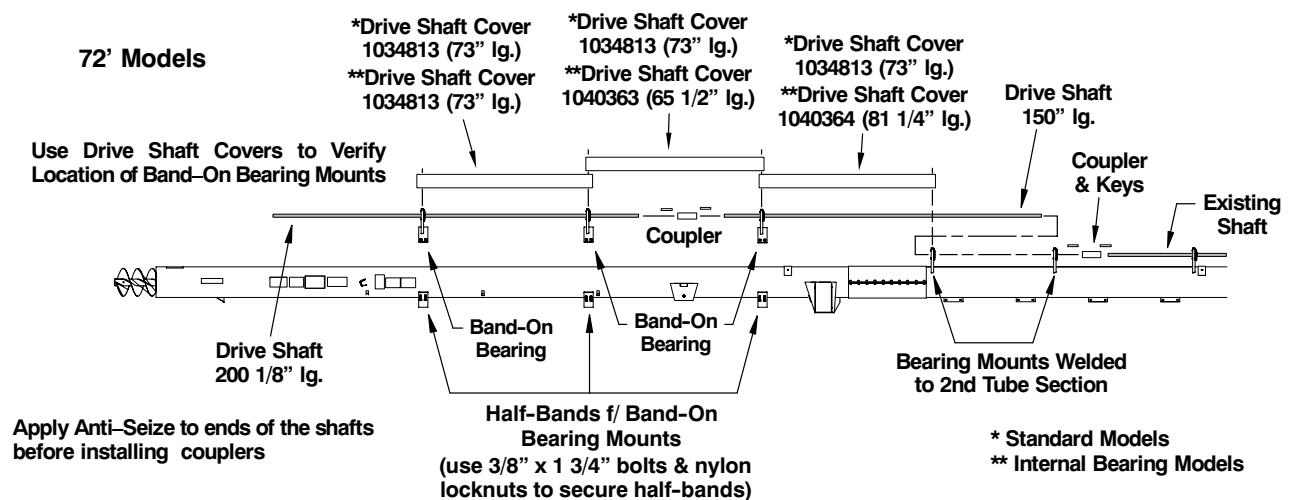



# ASSEMBLY INSTRUCTIONS

## **GEARBOX INSTALLATION for PTO DRIVE UNITS**

Refer to Page 39 for the gearbox installation on electric drive models.

**IMPORTANT! The gearbox is shipped without oil. Oil *must* be added before operation.** Refer to the Lubrication and Maintenance Section on Page 22 for proper filling procedures.

1. Once all drive shafts and band-on bearing supports have been assembled, install the gearbox mount plate and gearbox. Position the PTO gearbox mount plate and half-bands at the inlet end of the auger close to the end of the driveshaft.

Loosely attach the mount plate and half-bands using eight (8) 3/8" x 1 3/4" bolts and nylon locknuts (See illustration below).

2. Set the gearbox on top of the mount plate and secure using four (4) 1/2" x 1" bolts and lock washers.

3. **Apply an anti-seize compound to the end of the drive shaft.** Install the coupler and 3/8" x 2 1/2" long key to the end of the drive shaft and secure coupler to shaft (leave a 1/16" to 1/8" gap between the end of the shaft and the snap ring in the coupler, See illustration in following column).

4. **Apply an anti-seize compound to the gearbox shaft.** Insert the 3/8" sq. x 2" key into the end of the gearbox shaft and slide the gearbox and mount assembly towards the driveshaft, inserting the shaft into the coupler (leave a 1/16" to 1/8" gap between the end of the shafts and the snap ring in the coupler, See illustration below).

Make sure the driveshaft is properly aligned and the band-on bearing supports are positioned properly. Tighten the hardware securing the gearbox mount, its half-bands and the bearing support half bands.

It is important to keep the driveshafts aligned the entire length of the auger. If necessary make adjustments to the gearbox mount to ensure proper alignment of the drive shaft from the gearbox to the first bearing support.

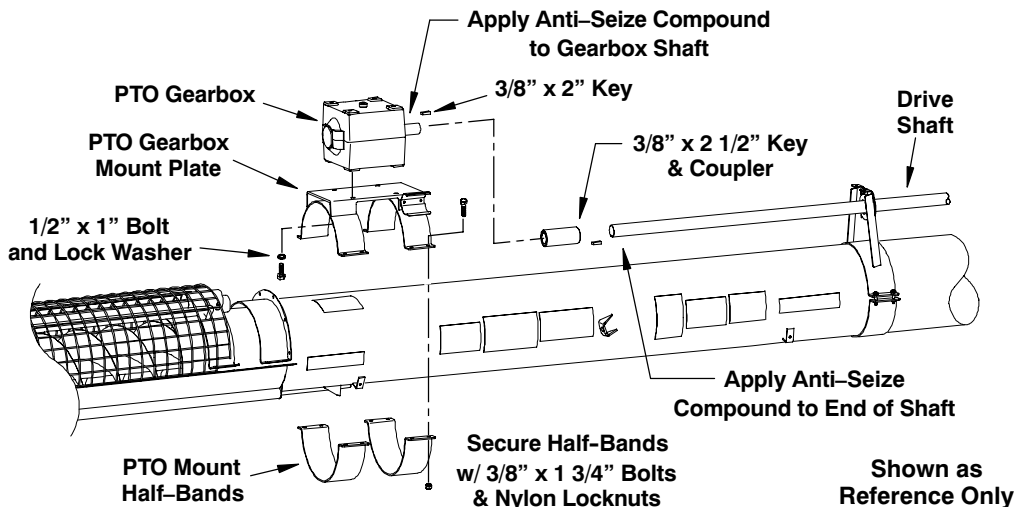
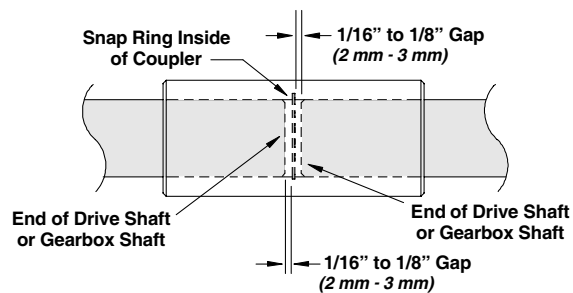

## PTO DRIVELINE INSTALLATION

1. Position the PTO driveline transport/storage cradle and attaching half-band onto the auger housing approximately 85 3/8" from the intake edge of the lower tube section (See illustration on following page). Using two (2) 3/8" x 1 3/4" bolts and nylon locknuts, loosely attach the cradle and half-band to the housing (some adjustment may be necessary so do not completely tighten the hardware at this time).
2. Slide the PTO u-joint shield over the end of the PTO driveline. Install a 3/8" sq. x 2" key into the keyway on the gearbox input shaft, apply an anti-seize compound to the shaft and attach the 1 3/4" diameter bore end of the driveline to the input shaft. Make sure the key is properly installed and ensure the setscrews in the u-joint yoke are tightened properly (one of the setscrews needs to be positioned on the flat portion of the input shaft as shown in the illustration below).

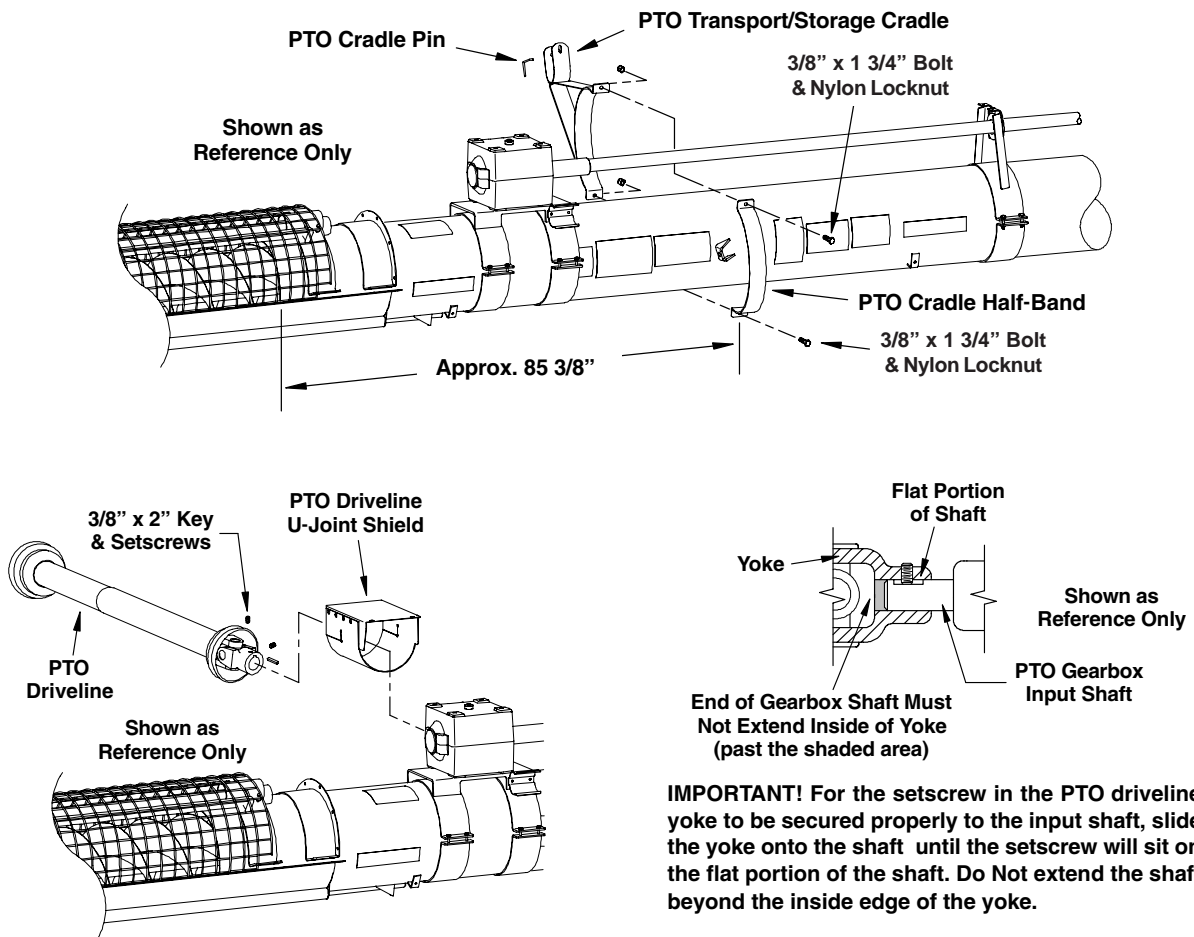

# ASSEMBLY INSTRUCTIONS

## PTO DRIVELINE INSTALLATION (con't.)

- Secure the u-joint shield along with the drive shaft cover to the top of the PTO gearbox using three 1/2" x 3/4" bolts (one corner of the drive shaft cover will sit on top of the u-joint shield using the same bolt to fasten both the shield and cover to the gearbox, See illustration below).

Before tightening the bolts securing the drive shaft cover, verify the mounting holes in the cover are aligned with the holes on top of the bearing support bracket, make any necessary adjustments, then tighten hardware.

- Position the PTO driveline so it will swing out towards the transport/storage cradle. Keeping the driveline parallel with the auger housing, position the cradle and half-band so the cradle supports the driveline just behind the safety shroud and u-joint.

After the transport/storage cradle is properly positioned and supporting the driveline, tighten the hardware securing the cradle and half-band.

Insert the cradle pin to lock the driveline into the cradle. **The driveline should always be stored in the transport/storage cradle when not in use and during transport.**

- Snap the operator's manual container into the holder located on the right hand side of the PTO gearbox mount.

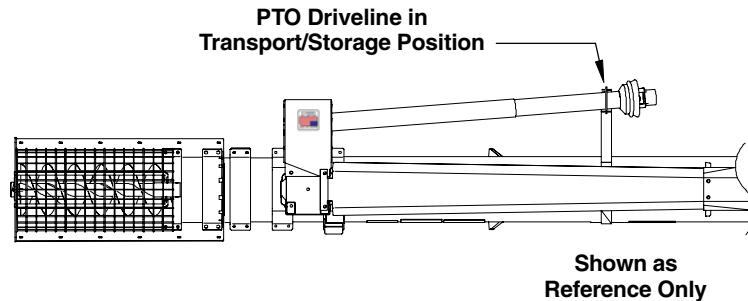
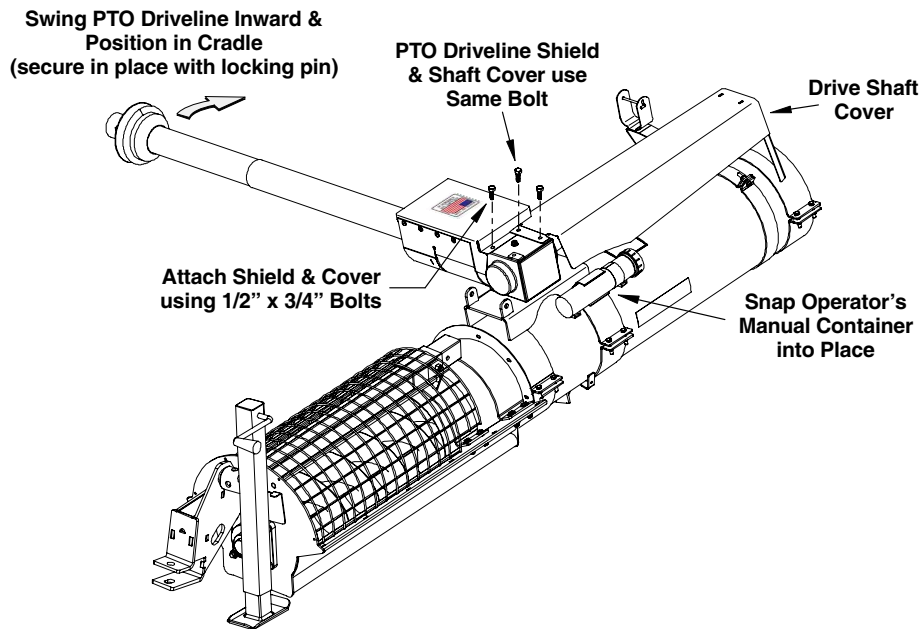

## UNDER TRUSS TOWER INSTALLATION

### Install Under Truss Tower

1. Attach the under truss tower to the undercarriage mount plate using four (4) 3/8" x 1" bolts and nylon locknuts (position the truss tower with the angled side facing the inlet end of the auger, See illustration below).
2. Insert a 5/8" eye bolt through the cable anchor located on the bottom of the first tube section as shown below. Thread two 5/8" non-lock nuts onto the end of the eye bolt leaving about 1" of the threads exposed.  
Insert another 5/8" eye bolt into the anchor strap located on the rear side of the winch mount and thread two 5/8" non-lock nuts onto the eye bolt as well (See illustration below).
3. Locate the short 1/2" diameter cable from the box of parts (cable lengths vary dependant on auger model).
4. Insert one end of the cable through the eye bolt at the inlet end and secure the cable end with two (2) 1/2" cable clamps (position the u-bolt portion of the clamp against the loose end of the cable as shown below).
5. Route the cable through the tube welded to the bottom of the truss tower and up to the eye bolt located at the winch mount.  
Pull excess slack from the cable and secure the end of the cable using two (2) 1/2" cable clamps positioning the u-bolt portion of clamp against the loose end of the cable.
6. Using the 5/8" nuts on the eye bolts, tighten the cable until cable is taut. Secure the two nuts on the eye bolts by tightening them against each other.

### Under Truss Cable Lengths

72' Models - 1/2" dia. x 14' 3"

82' Models - 1/2" dia. x 21' 2"

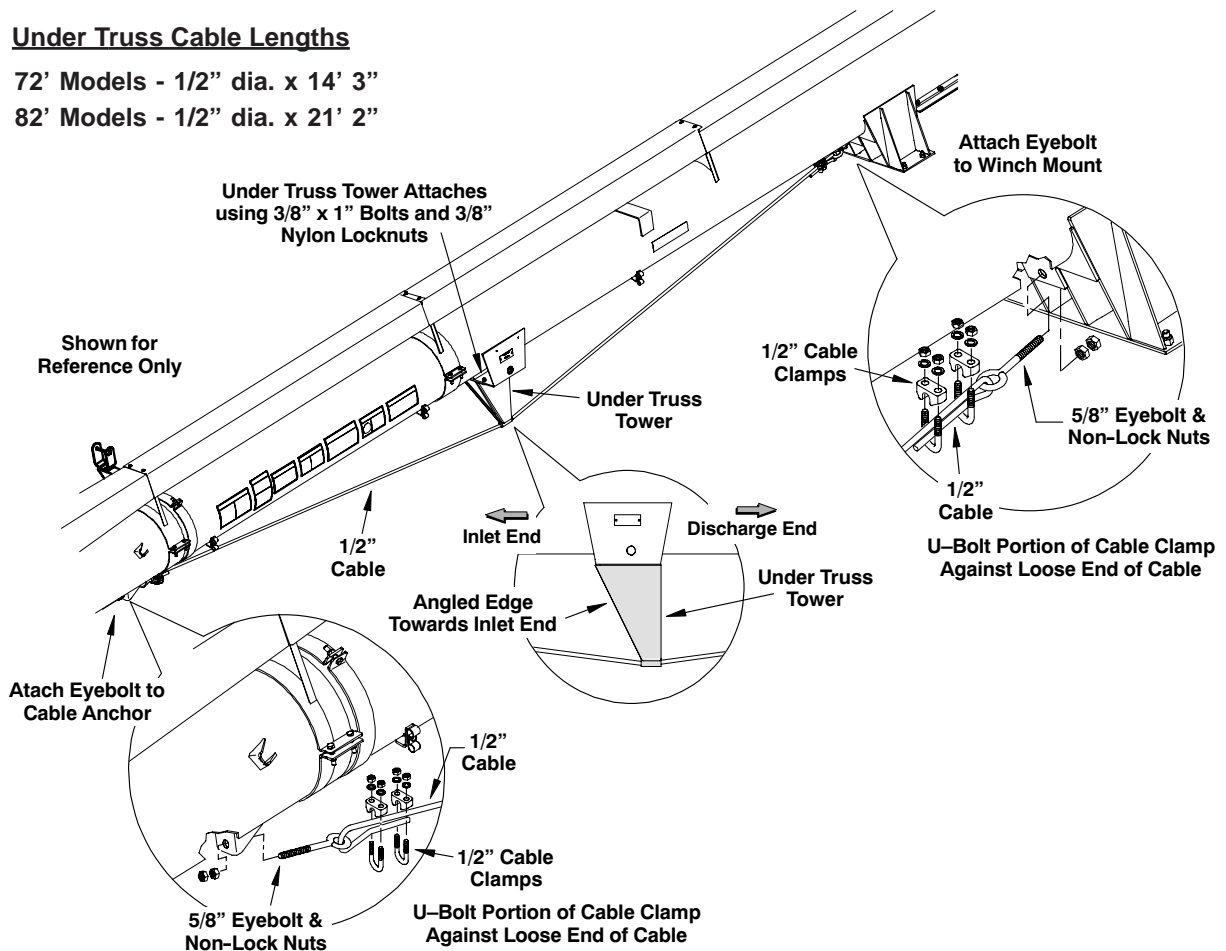

# ASSEMBLY INSTRUCTIONS

## **ELECTRIC DRIVE INSTALLATION**

**IMPORTANT! The gearbox is shipped without oil. Oil *must* be added before operation.** Refer to the Lubrication and Maintenance Section on Page 22 for proper filling procedures.

1. After all drive shafts have been installed, position the gearbox mount plate and half-bands at the inlet end of the auger close to the end of the drive shaft. Loosely attach the mount plate and half-bands using eight (8) 3/8" x 1 3/4" bolts and nylon locknuts (See illustration on Page 41).
2. Set the gearbox on top of the mount plate and secure using four (4) 1/2" x 1" bolts and lock washers.
3. **Apply an anti-seize compound** to the end of the drive shaft and install the 3/8" x 2 1/2" long key and coupler to the end of the drive shaft.  
Insert the 3/8" sq. x 2" key into the keyway on the gearbox shaft and slide gearbox mount assembly towards the drive shaft, inserting the gearbox shaft into the coupler.
4. Make sure the gearbox and drive shaft are aligned and tighten the setscrews in the coupler and tighten the hardware securing the gearbox mount and half-bands. **IMPORTANT! Keep the drive shafts aligned the entire length of the auger. If necessary, realign gearbox to keep shaft in alignment with the first bearing support).**
5. Install the motor mount plate. Position the motor mount plate over the back side of the gearbox. Lower the mount plate so the mounting ears on the motor mount plate align with the ears on the gearbox mount and the holes on top of the gearbox align with the holes on the mount plate. **The motor mount ears will be on positioned on the right side of the gearbox mount ear (See illustration on following page, Page 41).**
6. Secure the motor mount plate to the top of the gearbox using two (2) 1/2" x 1" bolts, lock washers and flat washers.  
Secure the ears on the mount plates using two (2) 1/2" x 1 1/2" bolts and nylon locknuts.
7. Secure the motor mount half-bands to the mount using four (4) 3/8" x 1 3/4" bolts and nylon locknuts.
8. Slide the belt guard mount bracket onto the motor mount tubes as shown on Page 41. Loosely attach the bracket using four (4) 5/16" x 2 1/2" bolts and nylon locknuts. Install the bolts so one is on each side of each tube (See illustration on Page 41).
9. Loosely attach the belt guard brace to the front left hole on top of the gearbox using one (1) 1/2" x 1" bolt, lock washer and flat washer. **NOTE: The drive shaft cover will be fastened to the gearbox and will also use this bolt.**

# ASSEMBLY INSTRUCTIONS

## ELECTRIC DRIVE INSTALLATION (con't.)

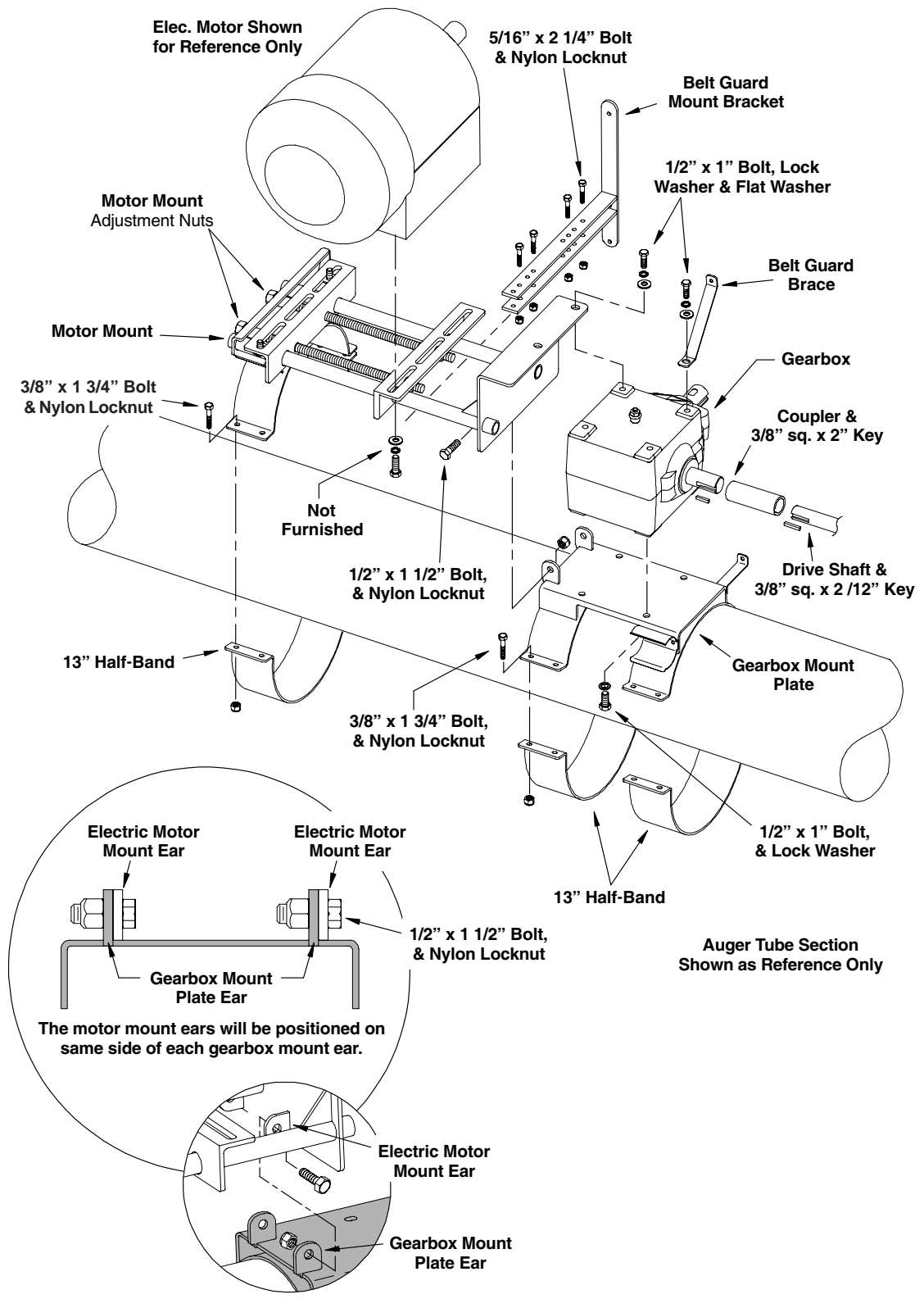

# ASSEMBLY INSTRUCTIONS

## ELECTRIC DRIVE INSTALLATION (con't.)

10. One of the motor mount plates is attached to the threaded adjustment rods, the other mount plate will slide freely. Adjust the threaded rods to allow the proper distance between each mount plate for motor installation **(the motor and its mounting hardware are not furnished. Refer to Page 7 for proper motor size and information).**

Install the appropriate sized motor. Leave the motor hardware loose enough to allow movement of the motor when installing the belt guard and sheaves.

11. Install the belt guard aligning its mounting holes with the mount brackets previously installed. There is also a belt guard bracket that is already welded to the gearbox mount plate which will be located at the lower end of the belt guard.

Position the belt guard mount bracket attached to the two mount tubes, with the appropriate mounting holes in the belt guard and secure using two (2) 5/16" x 1" bolts, flat washers and nylon locknuts.

Align each of the remaining brackets with the belt guard mount holes and secure with each with one (1) 5/16" x 1" bolt, flat washer and nylon locknut.

Tighten the four 5/16" x 2 1/4" bolts securing the belt guard mount bracket to the motor mount tubes.

12. **Apply anti-seize compound to the motor shaft and to the gearbox shaft.** Install the appropriate bushing and sheave to the motor shaft **(the motor sheave and bushing are not furnished).** Install the 12.4" sheave, QD bushing and 2" key to the gearbox shaft. Align the two sheaves by placing a straight edge on the face of each. Secure the motor to the motor mount plates and check sheave alignment. Make any necessary adjustments and secure sheaves into place tightening the setscrews to lock sheaves to the shafts.
13. Install the belts over the sheaves. Using the two adjustment nuts on each of the threaded rods, tighten the belts until proper tension has been achieved. Make sure to adjust the nuts equally to keep the motor drive sheave properly aligned.

**Proper belt tension is approximately 9/16" of deflection per belt when using 7.50 lbs. of force at the center of the span between the two sheaves.**

After 24 hours of operation, and for the remainder of belt life, deflection should be 9/16" using 4.00 to 4.50 lbs. of force.

If you do not have a weight set to apply the recommended force, a fish scale is a good alternative. Tension can also be checked by pressing firmly on the belts at the center of the span between the two sheaves.

14. Snap the Operator's Manual container into the holder located on the right side of the gearbox mount plate. **Ensure there is an Operator's Manual kept in the container at all times.**

# ASSEMBLY INSTRUCTIONS

## ELECTRIC DRIVE INSTALLATION (con't.)

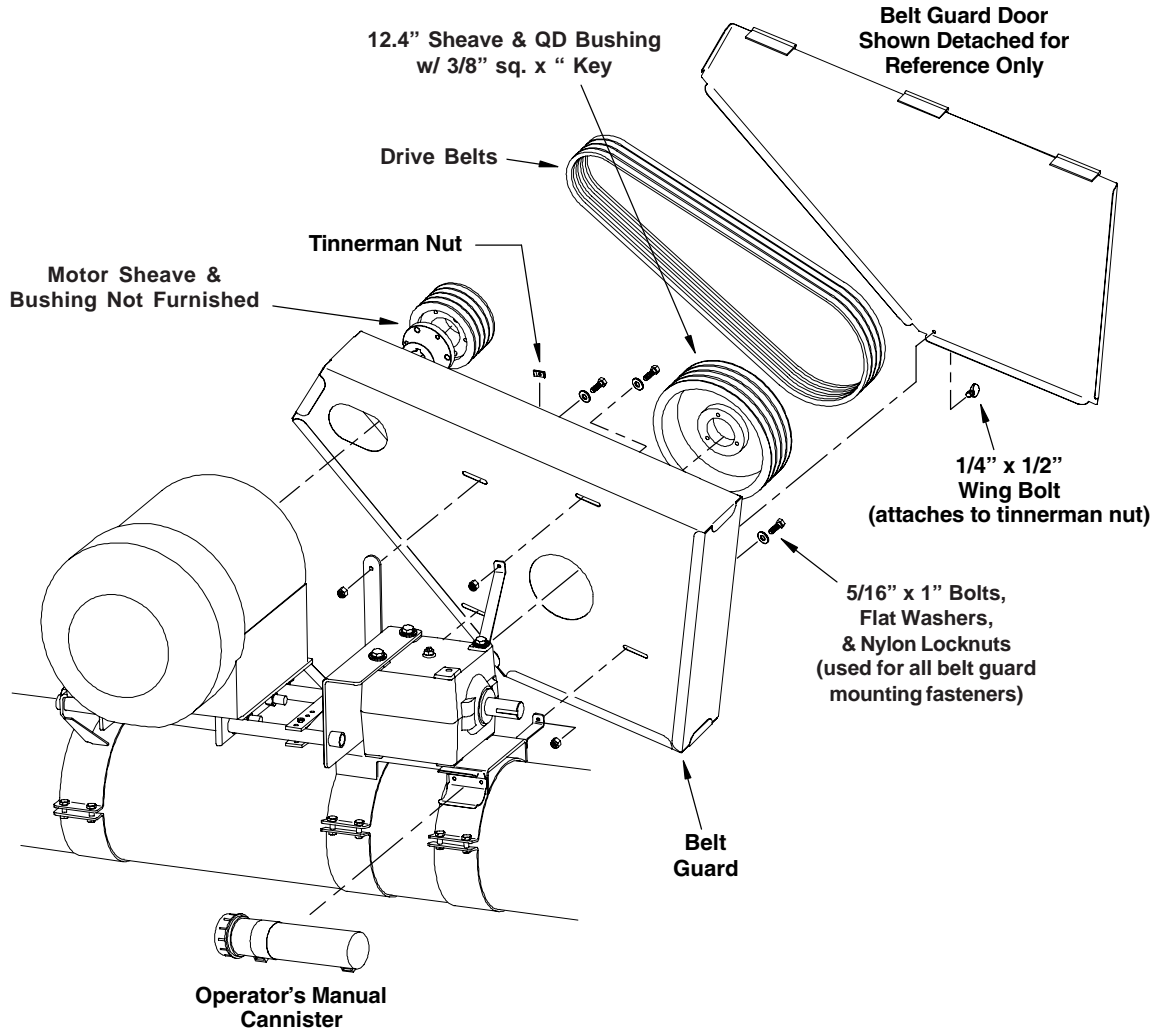

# ASSEMBLY INSTRUCTIONS

## DRIVE SHAFT COVER INSTALLATION

Note that the drive shaft covers are slightly wider at one end. The narrow end of the cover has rounded corners for ease of identification. The narrow end (with rounded corners) will face towards the discharge end of the auger. The wider end will always be positioned on top of the previous cover as shown in the illustration below.

The covers also come in various lengths. Use the following illustrations to determine proper sequence when assembling the covers.

1. The covers will overlap each other at each bearing support with the narrow end resting on the bearing support and the wider end positioned over the previous cover.

Begin at the lower end of the auger and install the covers as you work towards the discharge end of the auger. Secure the covers using two 1/4" x 3/4" self tapping screws.

**Installation for the PTO Drive Models is shown on Page 45, installation for Electric Drive Models is shown on Page 46.**

**Refer to Page 59 and 60 for sequence of drive shaft covers for models with optional Internal Bearings.**

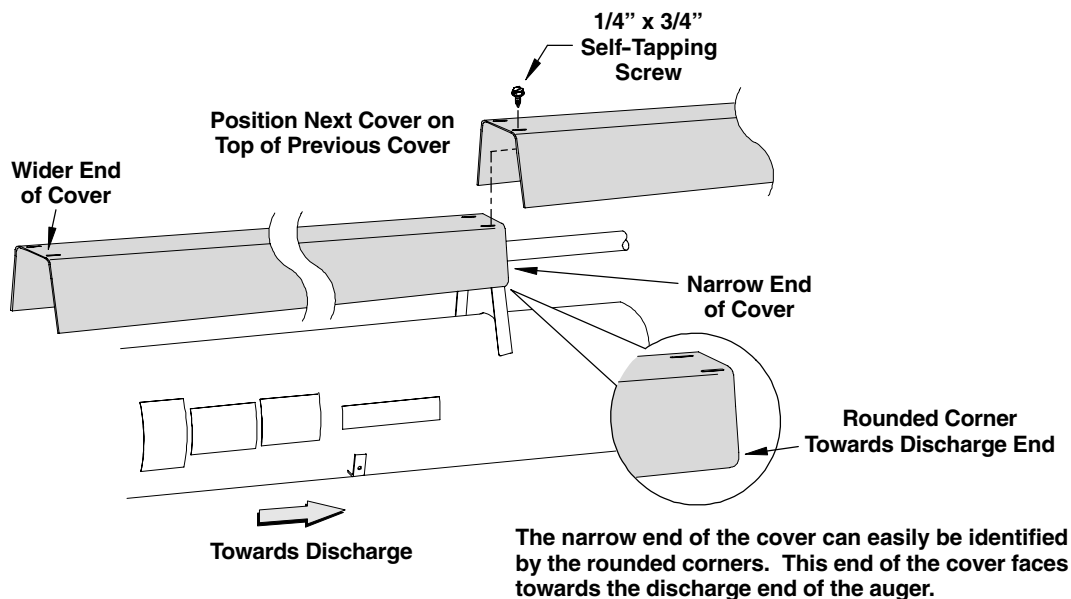

# ASSEMBLY INSTRUCTIONS

## DRIVESHAFT COVER INSTALLATION (con't.)

### PTO Drive Models

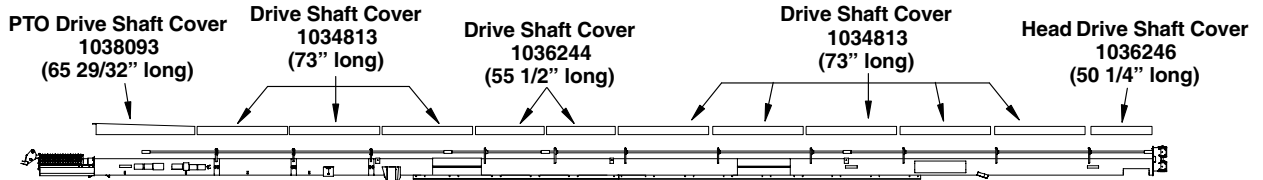

#### 72' PTO Drive Models

All Drive Shaft Covers are Secured with 1/4" x 3/4" Self Tapping Screws, Except PTO Shaft Cover to Gearbox, it Attaches with the PTO Gearbox U-Joint Shield & uses 1/2" x 3/4" bolts

<b>Driveshaft Cover Sequence</b>	1 ea. - 1038093	65 29/32" long
<b>Beginning at Intake End</b>	3 ea. - 1034813	73" long
<b>72' PTO Drive Models</b>	2 ea. - 1036244	55 1/2" long
	5 ea. - 1034813	73" long
	1 ea. - 1036246	50 1/4" long

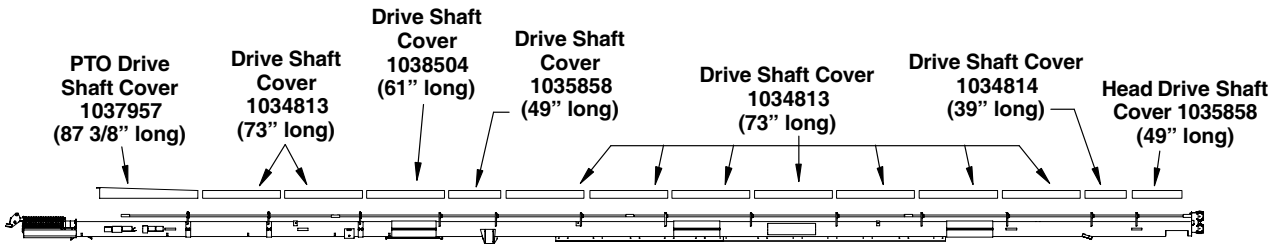

#### 82' PTO Drive Models

All Drive Shaft Covers are Secured with 1/4" x 3/4" Self Tapping Screws, Except PTO Shaft Cover to Gearbox, it Attaches with the PTO Gearbox U-Joint Shield & uses 1/2" x 3/4" bolts

<b>Driveshaft Cover Sequence</b>	1 ea. - 1037957	87 3/8" long
<b>Beginning at Intake End</b>	3 ea. - 1034813	73" long
<b>82' PTO Drive Models</b>	1 ea. - 1038504	61" long
	1 ea. - 1035858	49" long
	7 ea. - 1034813	73" long
	1 ea. - 1034814	39" long
	1 ea. - 1035858	49" long

# ASSEMBLY INSTRUCTIONS

## DRIVESHAFT COVER INSTALLATION (con't.)

### Electric Drive Models

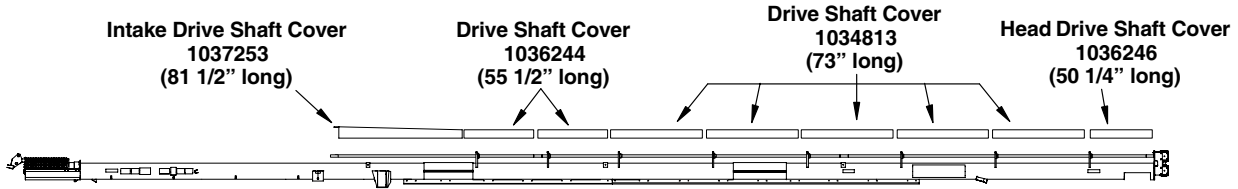

#### 72' Electric Drive Models

All Drive Shaft Covers are Secured with 1/4" x 3/4" Self Tapping Screws,  
Except Drive Shaft Cover to Gearbox, it uses 1/2" x 3/4" bolts

<b>Driveshaft Cover Sequence</b>	1 ea. - 1037253	81 1/2" long
<b>Beginning at Intake End</b>	2 ea. - 1036244	55 1/2" long
<b>72' Electric Drive Models</b>	5 ea. - 1034813	73" long
	1 ea. - 1036246	50 1/4" long

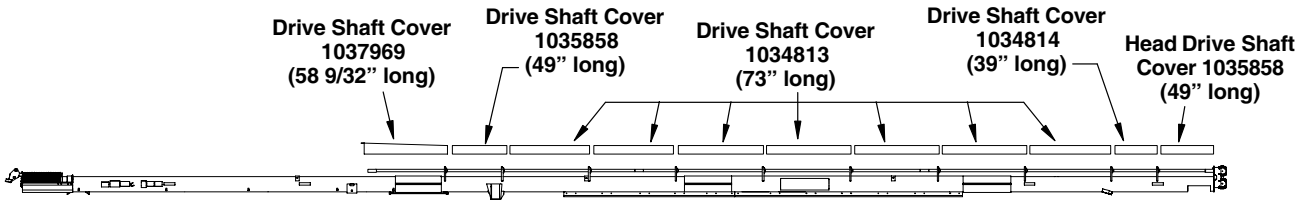

#### 82' Electric Drive Models

All Drive Shaft Covers are Secured with 1/4" x 3/4" Self Tapping Screws,  
Except Drive Shaft Cover to Gearbox, it uses 1/2" x 3/4" bolts

<b>Driveshaft Cover Sequence</b>	1 ea. - 1037969	58 9/32" long
<b>Beginning at Intake End</b>	1 ea. - 1035858	49" long
<b>82' Electric Drive Models</b>	7 ea. - 1034813	73" long
	1 ea. - 1034814	39" long
	1 ea. - 1035858	49" long

## TROLLEY & TROLLEY STOPS



**WARNING!** The trolley will roll freely on the tracks. After upper trolley stop has been installed, secure the trolley to the stop to prevent it from rolling. Be aware of pinch points during the assembly process. Use caution around these areas.

### Install Trolley & Upper Trolley Stop

1. Slide the trolley onto the tracks from the discharge end of the auger (pulley assembly facing inlet end).
2. Locate the eight (8) mounting holes (4 in each track) in the upper track sections. Secure the upper trolley stop to the tracks using eight (8) 7/16" x 1 1/4" bolts, flat washers and nylon locknuts.

Use a strap or similar means to temporarily secure the trolley to the upper stop to prevent it from rolling during the remainder of the auger assembly process.

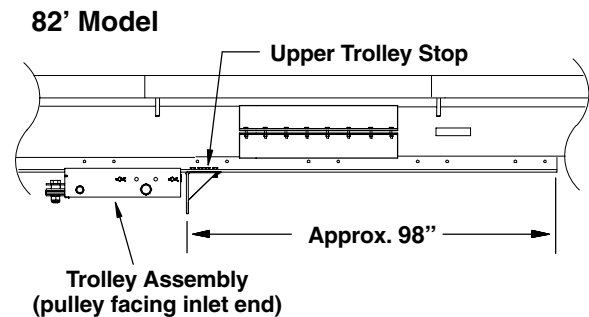
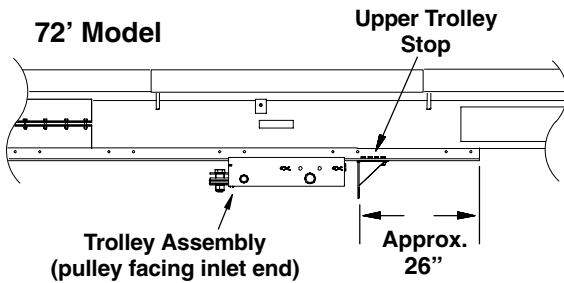
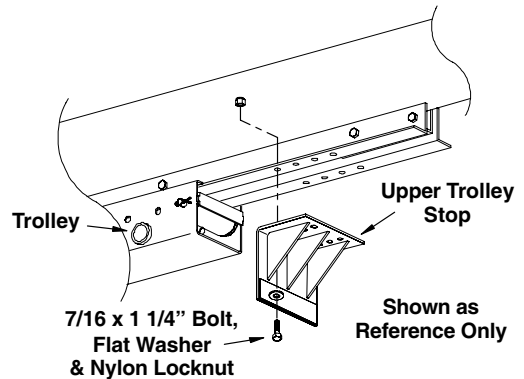

### Install Lower Trolley Stop

1. The lower trolley stop will mount to the tracks at the lowest set of holes at the inlet end of the tracks. Attach the lower stop using four (4) 1/2" x 1 1/2" bolts, flat washers and nylon locknuts.

The measurements on the mounting holes for the lower stop are taken from the inlet end of the track to the first mounting hole.

72' Models are approximately 35"

82' Models are approximately 8 1/8"

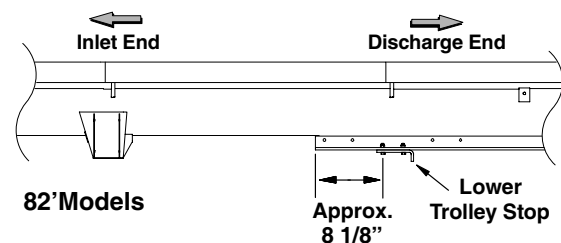
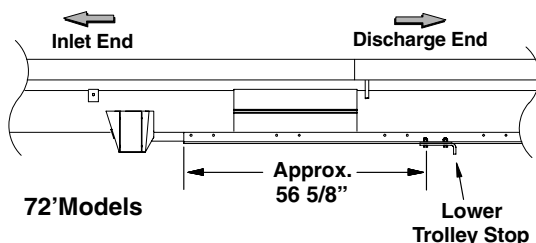
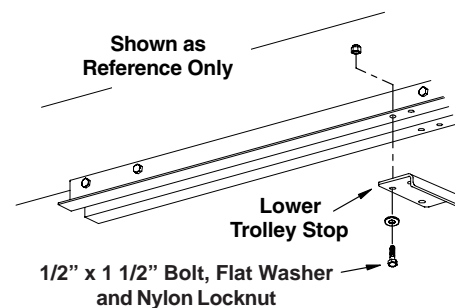

# ASSEMBLY INSTRUCTIONS

## TRUSS ASSEMBLY

1. Loosely attach the truss sides to the truss mounting brackets welded to the auger tubes. Secure each truss side using one (1) 5/8" x 1 1/2" bolt and nylon locknut. **72' & 82' Models will use three sets of truss stands, one set at intake end, one set at discharge end and one set in the middle (the middle truss stands will be taller than the intake and discharge end stands, see details below).**
2. Install the truss crossbraces between the sides and secure using two (2) 3/8" x 1 1/4" bolts and nylon locknuts. The longer crossbrace will attach to the upper portion of the truss sides and the shorter crossbrace will attach to the lower portion of the truss sides (keep the crossbraces square with the edges of the truss sides and tighten into place).
3. Tighten the hardware securing the truss sides to the mounting brackets (keep the truss sides square with the edges of the mount brackets).
4. Install the 5/8" x 11" eyebolts through the bottom truss anchors located on each side of the lower tube section (See Detail "B" on the following page, Page 49). Thread two 5/8" non-lock nuts onto the end of each eyebolt.
5. Locate the 1/2" diameter cable from the box of parts (117' long f/ 72' models, 142' long f/ 82' models). Find the middle of the cable by folding it in half and matching both loose ends of the cable. Using one (1) 1/2" cable clamp, attach the middle of the cable to the upper truss anchor. See Detail "C" on Page 49. Secure the cable and clamp to the truss anchor.
6. Temporarily route the cable over the top of the upper crossbraces and back down to the inlet end of the auger (the cable will attach to the eyebolts previously installed).
7. Attach the cable to the tops of the truss sides using the 1/2" cable clamps provided, See Detail "A" on Page 49. **Do Not tighten the clamps at this time.**
8. Insert each end of the cable through the eyebolts and pull the excess slack from the cables. Secure the cable ends using two (2) 1/2" cable clamps (See Detail "B" on Page 49). **Position the u-bolt portion of the clamp against the loose end of the cable.** Using the two 5/8" nuts on the ends of the eyebolts, tighten the cable until the truss is holding the auger straight, or until the upper portion of the auger has a slight bow at the discharge end. Tighten both eyebolts equally, making sure the auger is not being pulled to one side or the other. After the cable has been tightened, secure the two 5/8" nuts on the eyebolts by tightening them against each other.
9. Now go back and tighten all the cable clamps securing the cable to the tops of the truss sides. Check all hardware used to install the truss sections to ensure it has been properly tightened.
10. Check down the length of the auger again to make sure everything stayed aligned as the hardware was and cable clamps were tightened. Make any necessary adjustments.
11. It may be necessary to cut excess cable ends (if so, leave a minimum 6" of cable past the u-bolts).

**All lengths are approximate. Some truss sides and crossbraces may measure slightly longer than the dimension shown.**

**72' Models:** Truss Sides – 4 ea. 40 1/2" long (two at intake end, two at discharge end)  
Cross Brace – 3 ea. 18" (lower brace, f/ intake & discharge end and middle stand)  
Truss Sides – 2 ea. 43 1/2" long (f/ middle truss stand)  
Cross Brace – 2 ea. 30" (upper brace, f/ intake and discharge ends)  
Cross Brace – 1 ea. 32" (upper brace, f/ middle truss stand)

**82' Models:** Truss Sides – 4 ea. 40 1/2" long (two at intake end, two at discharge end)  
Cross Brace – 3 ea. 18" (lower brace, f/ intake & discharge end and middle stand)  
Truss Sides – 2 ea. 43 1/2" long (f/ middle truss stand)  
Cross Brace – 2 ea. 30" (upper brace f/ intake and discharge ends)  
Cross Brace – 1 ea. 32 1/32" (upper brace f/ middle truss stand)

# ASSEMBLY INSTRUCTIONS

## TRUSS ASSEMBLY

72' & 82 Models Use 3 Sets of Truss Stands

72' Model Shown for Reference Only

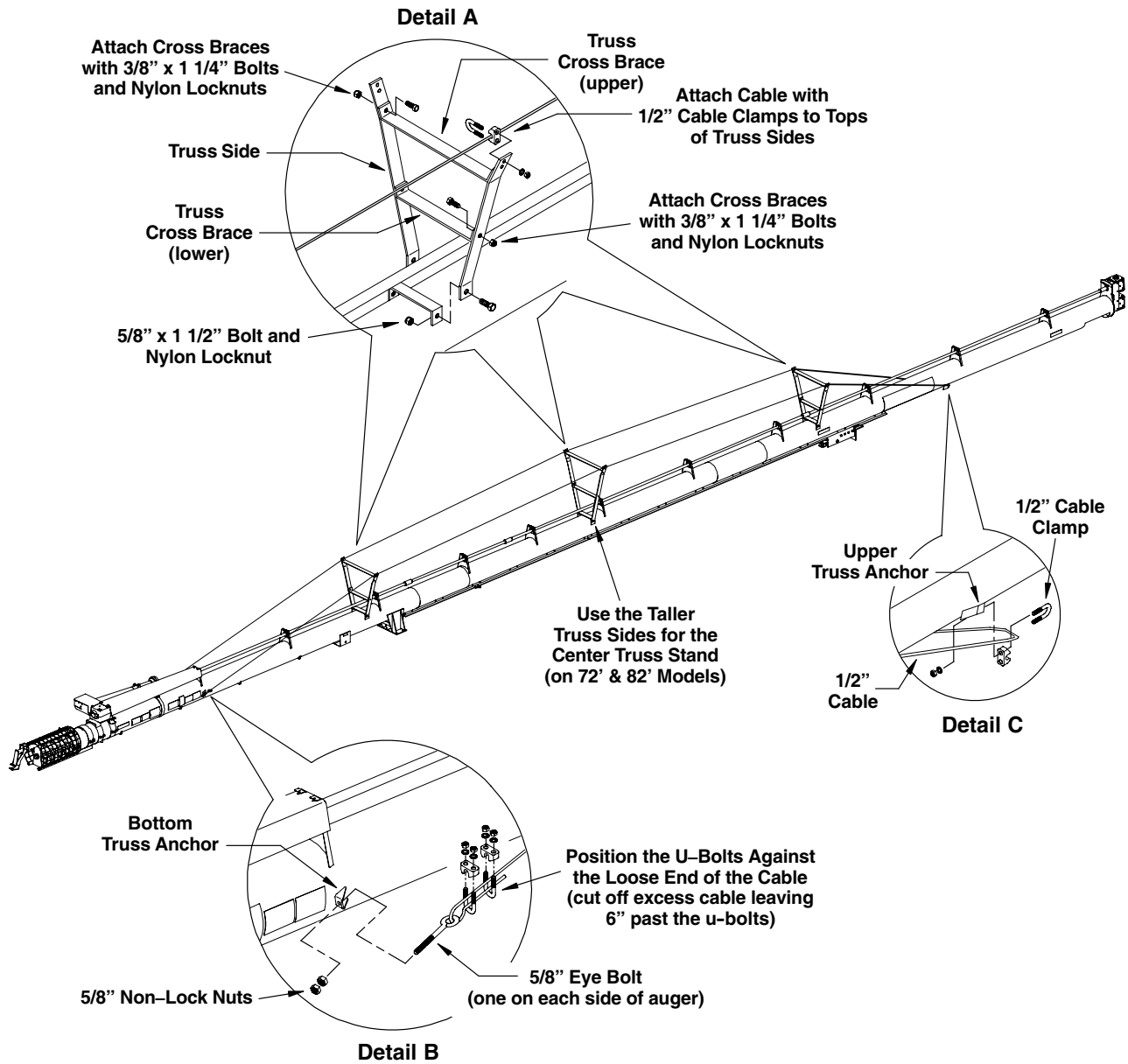

# ASSEMBLY INSTRUCTIONS

## UNDERCARRIAGE ASSEMBLY

When assembling the undercarriage, leave all bolts loose until all components of the carriage have been installed, or until otherwise instructed in the assembly procedures.

Use the illustration on Page 51 to assist with assembly procedures as well as parts identification.

The following instructions show a reference number in parenthesis ( ), this number refers to the item shown in the assembly illustration on Page 51.

1. Bolt the conveyor axle (Ref. 1) to the lower radius arms (Ref. 2 & 3) using six 5/8" x 2" bolts and nylon locknuts. **NOTE: The lower radius arms will bolt on the inside of the axle plate (See Detail "A" on Page 51).** Make sure the axle is oriented so the reflective decals are facing up.

2. Install the longer x-brace tubes (Ref. 4) to the lower radius arms using four 1/2" x 1 1/2" bolts, flat washers and nylon locknuts. **Note: All x-brace tubes have a hole near the center of the tube but is offset to one end, this hole should be positioned towards the narrow end of the radius arms.**

The long x-brace tubes measure 103 23/32" long for the 72' Models and 99 23/32" long for the 82' Models.

The x-brace tubes will be secured together using the offset hole that was positioned at the narrow end of the arms. Secure using one 1/2" x 3 1/4" bolt, flat washer and nylon locknut.

3. Attach the upper lift arms (Ref. 5 & 6) to the lower radius arms (Ref. 2 & 3). Secure each arm using one 1" x 3" bolt, flat washer, one spacer bushing (Ref. 7) and one nylon locknut, See Detail "A" (the bushing dimension used to connect the upper and lower arms together is 1 1/2" O.D. x 1 1/16" I.D. x 11/16" long).

4. Bolt the shorter x-brace tubes (Ref. 8) to the upper lift arms using four 1/2" x 1 1/2" bolts, flat washers and nylon locknuts. Make sure the offset holes are facing towards the narrow end of the lift arms.

The short x-brace tubes measure 95 3/4" long for the 72' Models and 95 1/4" long for the 82' Models.

5. Attach the connecting brace tube (Ref. 9) to the bottom side of each lower radius arm as shown in Detail "A" on Page 51. Secure the connecting tube using two 1/2" x 1 1/2" bolts and nylon locknuts.

**IMPORTANT! The connecting tube *MUST* be installed on the *BOTTOM* side of the lower radius arms as shown in Detail "A" on Page 51.**

**IMPORTANT! Always use straps or similar means wrapped completely around the conveyor housing when raising the conveyor during the assembly process. Never raise the conveyor using the drive shafts or any other components that are attached to the conveyor.**

6. Using an overhead hoist or similar means, position the conveyor housing over the undercarriage so the trolley is positioned above the ends of the upper lift arms.

Install the 7 5/8" long bushing (Ref. 10) into the trolley (Ref. 11) and position trolley between the lift arms (remove the temporary strap that was used to hold the trolley in place).

Secure the trolley to the lift arms using one 1" x 11" long bolt, two flat washers and nylon locknut.

7. Tighten all hardware in the upper lift arm assembly, including the bolts connecting the upper lift arms and lower radius arms together.

8. Raise the conveyor at a point approximately two-thirds of the distance towards the discharge end. Raise the conveyor only high enough to allow the lower radius arms to be attached to the undercarriage mount welded to the conveyor housing (See Detail "B" on Page 51).

Secure each of the lower arms to the mount using one 1" x 3" bolt, one spacer bushing (Ref. 12), one flat washer and nylon locknut. The flat washer goes under the head of the bolt with the bolt head on the outside, See Detail "B" on Page 53 (the bushing dimensions are 1 1/2" O.D. x 1 1/16" I.D. x 15/16" long).

**For 82' Models Only:** Install the cross stiffener brace (Ref. 13) between the lower radius arms as shown in the illustration on Page 51. Use the end plates (Ref. 14) and eight 1/2" x 5 1/2" bolts and nylon locknuts to secure the cross stiffener to the arms. Position the stiffener so that each end of the stiffener contacts the radius arms, then bolt into place.

9. Install the reflector brackets (Ref. 15) to the lower radius arms (near the axle) using two 5/16" x 1" bolts and nylon locknuts for each reflector.

Verify that all hardware used to assemble the undercarriage is tight.

10. If the wheel hubs have not been mounted onto the axle spindles at this point, refer to the hub assembly instructions on Page 18. Otherwise, mount the wheel and tires to the hubs and secure using the lug bolts provided.

## UNDERCARRIAGE ASSEMBLY

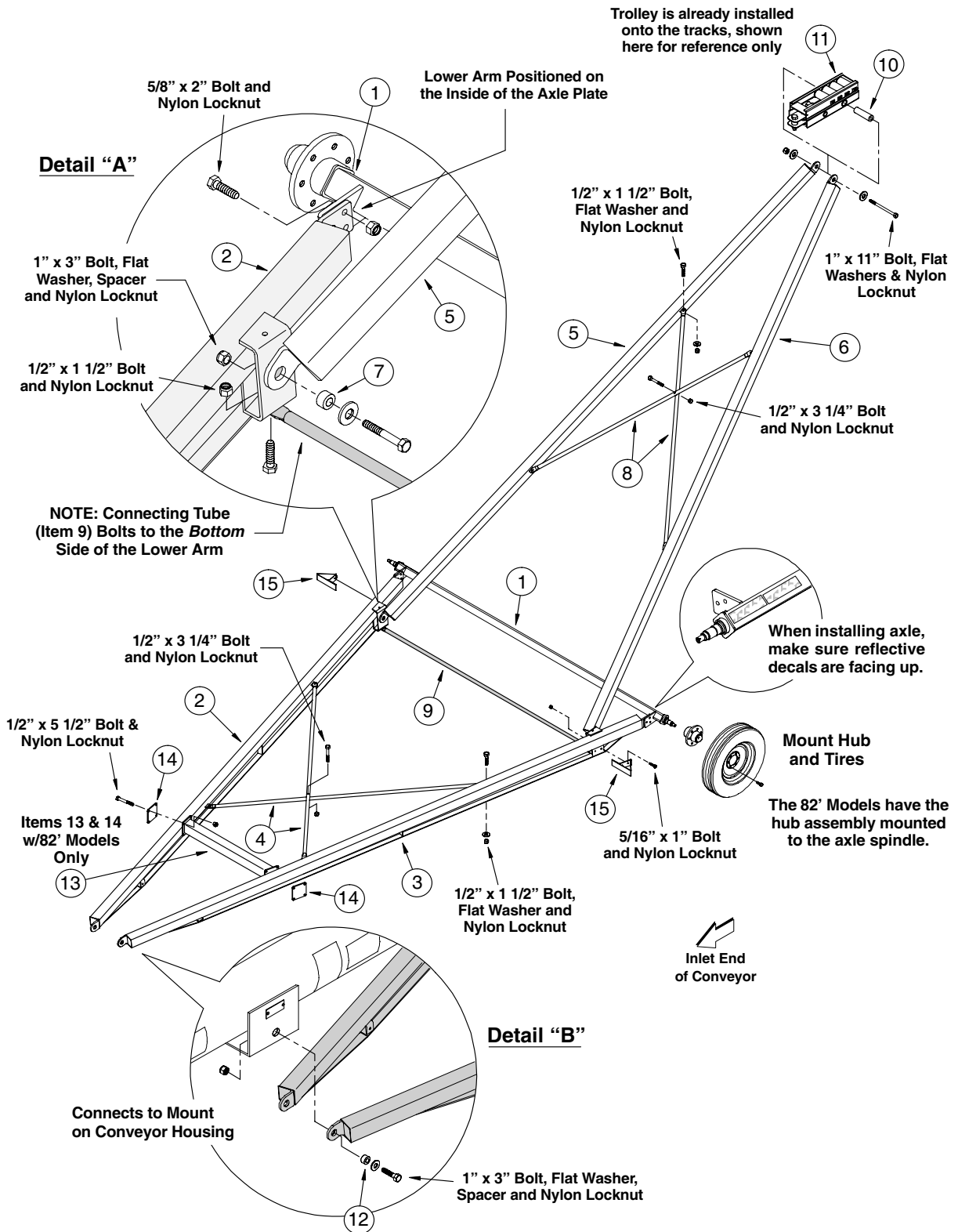

# ASSEMBLY INSTRUCTIONS

## WINCH & WINCH CABLE INSTALLATION

1. **For all 72' and 82' Models:** Slide the shorter pulley clevis onto the anchor pipe on the winch mount plate as shown in the illustration below. **NOTE: Because of the installation of the stiffener, the pulley assembly should already be installed on the 72' units.**

Stack the pulley, spacer bushing and washers as shown below. Install this assembly into the end of the clevis and secure using one 1" x 3 1/2" bolt and nylon locknut. Install the 1/4" x 2 1/2" bolt and nylon locknut.

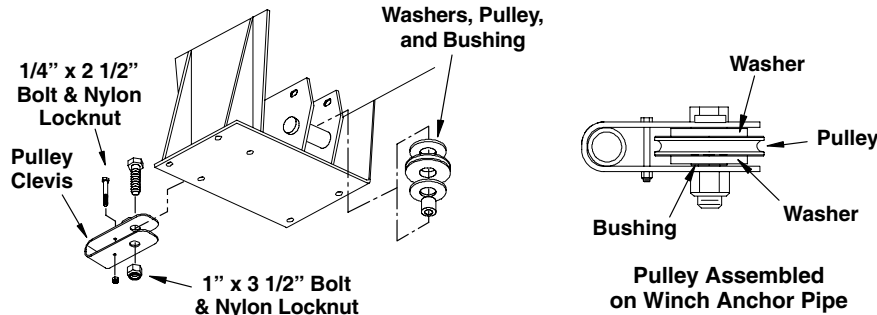

This Pulley Assembly Used on all 72' & 82' Units Equipped with Either Electric or Hydraulic Winch

2. **For all Models Equipped with Hydraulic Winch:** Remove the two shipping bolts from the top of the winch and discard bolts.
3. Position the hydraulic winch as shown below. Attach winch to the winch mount plate using six (6) 1/2" x 2 1/2" bolts and nylon locknuts.

**NOTE: Both the electric and hydraulic winches use the same mounting hardware and mount in the same location.**

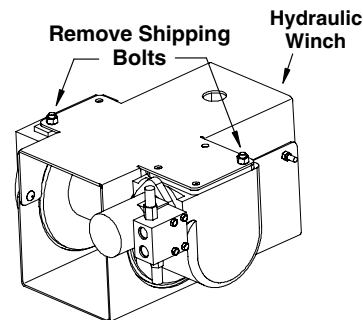

**For Electric Winches:** there are no shipping bolts, position the winch as shown below. Attach the winch to the winch mount plate using six (6) 1/2" x 2 1/2" bolts and nylon locknuts.

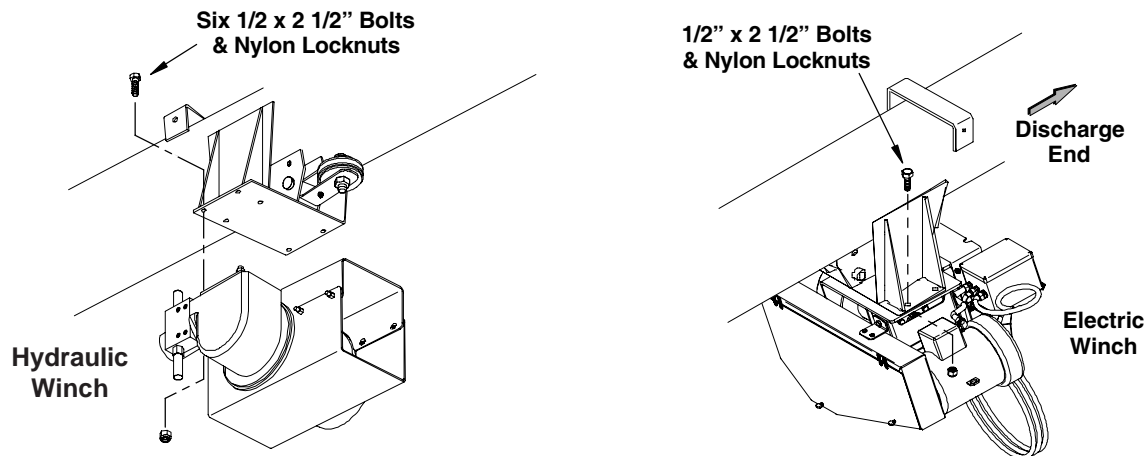

## WINCH & WINCH CABLE INSTALLATION (con't.)

**For all 72' & 82' Models Equipped with either the Hydraulic or Electric winch:** The winch cable will route from the winch drum, up to the trolley pulley, back down to the lower cable pulley and up again to the anchor bushing on the trolley (See illustration below). **Cable connection to the winch drum is the same for both winches.**

1. Attach the cable to the winch drum. Pass the free end of the cable over the top of the winch drum and make three wraps around the drum. Insert the cable end through the small opening in the drum and secure the cable to the drum using the existing anchor setscrew (keep a little tension on the cable so it does not come unraveled).

**IMPORTANT!** The cable anchor setscrew on the winch drum alone cannot support the weight of the auger. There should be a minimum of three complete wraps of cable around the drum when the auger is in the full down position.

2. Route the cable up and around the trolley pulley, making sure the cable is positioned between the pulley and the cotter pin. Bring the cable back down and around the cable pulley located on front of the winch mount (keep cable between the pulley and the 1/4" bolt), then route cable back up to the anchor bushing on the trolley pulley (See illustration below).

Pull any remaining slack from the cable and secure cable to the trolley anchor bushing using three (3) 1/2" cable clamps (the u-bolt portion of the clamp needs to be against the loose end of the cable).

### 72' & 82' Models Equipped with Either Hydraulic or Electric Winch

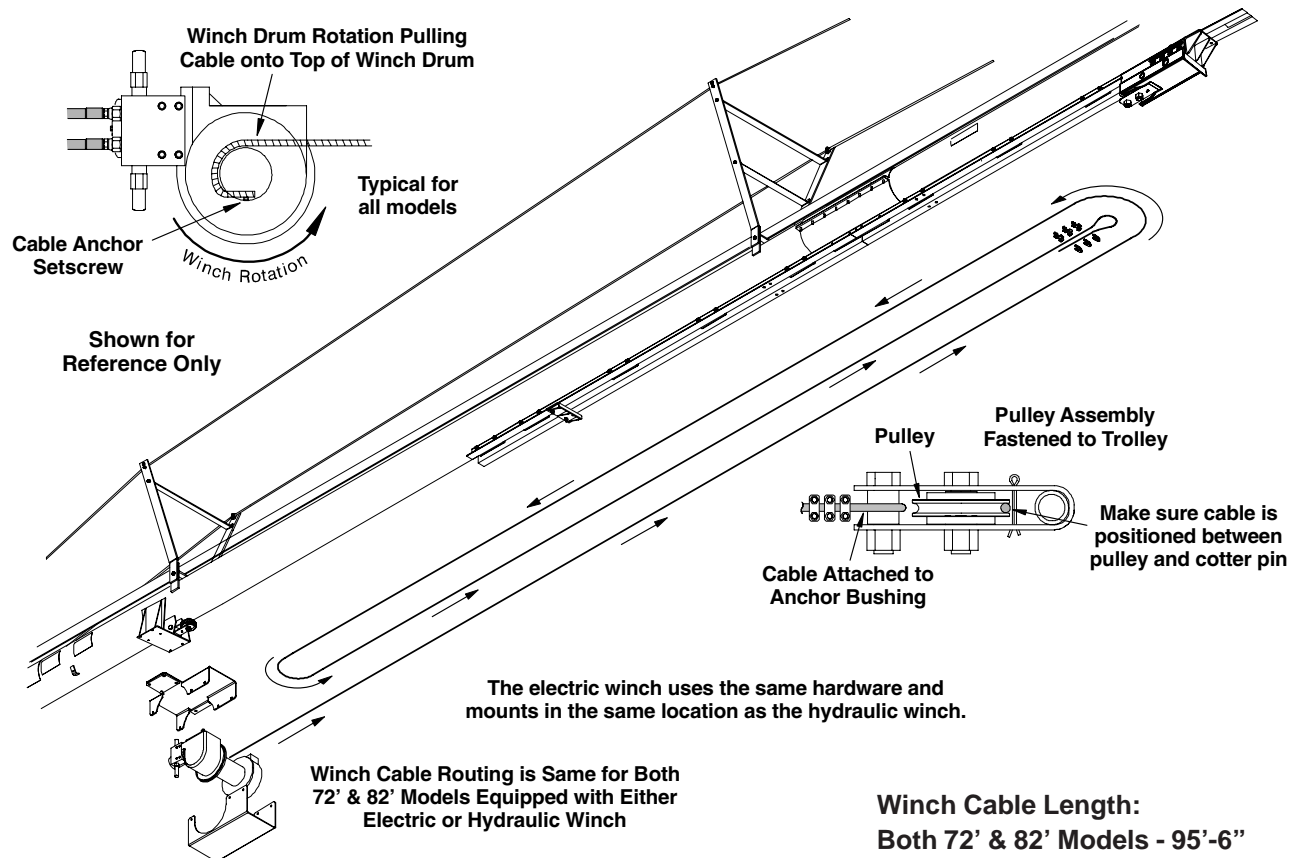

# ASSEMBLY INSTRUCTIONS

## HYDRAULIC HOSE INSTALLATION



**WARNING!** Hydraulic systems are highly pressurized. Do Not connect or disconnect hydraulic components when there is pressure within the system.

Escaping hydraulic oil, even an invisible pin hole leak can penetrate body tissues and cause serious injury.



Use a piece of wood or cardboard when searching for leaks, Never use your hands or other parts of your body.

If injured by hydraulic oil escaping under pressure, see a doctor immediately. Serious infection or reaction can occur if medical attention is not received at once.

**IMPORTANT!** Keep hydraulic hoses away from moving parts. Allow hoses to coil in their original shape. Avoid pinching, crimping or twisting hoses that would otherwise restrict the flow of hydraulic oil.

1. Attach the hydraulic hoses to the relief valve on the winch. Apply a thin coat of clean oil to the o-rings on the ends of the hose fittings and attach the hoses to the relief valve.
2. Pass the ends of the hoses through the undercarriage mount and route the hoses down to the inlet end of the auger. There are mounting brackets welded to the housing every few feet along the lower portion of the auger tubes. Attach the hoses to these brackets using the provided hose clamps and 1/4" x 1" bolts and lock washers (See illustration below).

After the hoses have been properly secured, it is good practice to always keep the excess length of hoses attached to the auger. This will help prevent damage to the hoses while in storage and while transporting. The fittings on the hose should also be covered, not only to keep dirt and other contaminants from collecting in the fittings, but to protect the threaded portion of the fittings as well.

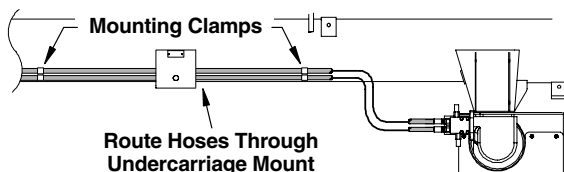
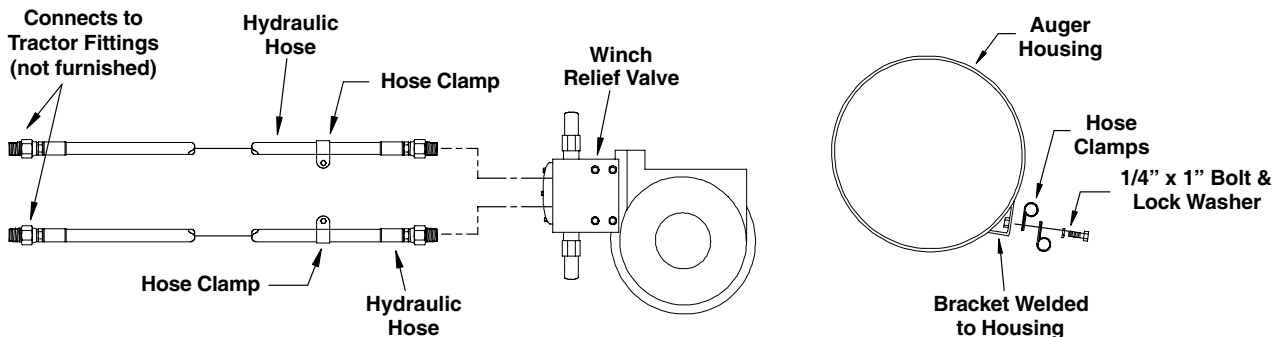

### Hose Lengths

72' Model	82' Model
3/8" dia. x 28'	3/8" dia. x 38'

Hose Connection to Relief Valve: SAE #10 Port, 7/8"-14 w/ O-Ring

Hose Connection for Tractor: 1/2" NPT Male

## INLET HOPPER ASSEMBLY

1. Install the filler plate to the front side of the inlet hopper as shown below. Secure using five (5) 5/16" x 3/4" bolts, flat washers and nylon locknuts (bolt heads from the inside, flat washers on outside of plate).
2. There is a right and left side panel with hinged doors and a long hinge along the bottom edge of the side panel (note the angle of the panels, position the lowest part of the angle towards the discharge end). Secure the long hinge to the inlet using 5/16" x 1 1/4" elevator bolts, flat washers and nylon locknuts. **IMPORTANT! Do Not open the hinge completely when attaching to the inlet. The hinge will be partially open with the bolt inserted through the folded side of the hinge, See illustration below.**
3. Locate the chain door strap from the hardware box, the chain has a 5/16" bolt and pin welded to it (see illustration below). Remove the nylon locknut from the bolt and secure the chain strap to the top of the left side hopper panel.
4. Position the doors to form an enclosure and secure using the long pins provided. The bottom of the pins will be inserted into the tab welded to the filler plate and to the rear side of the inlet assembly. After inserting the pins, secure them using the attached hair pin (when secured, the hair pin will be below the lip of the hopper panel). The pins will be stored in the door panels when the hopper is in the folded transport position (refer to the following page, Page 56 for hopper transport and storage information).

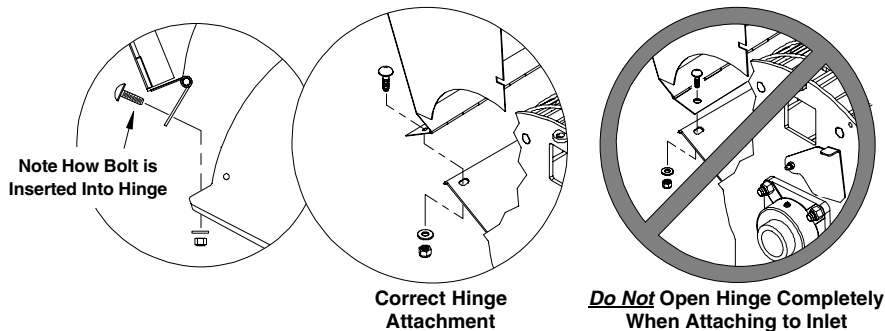
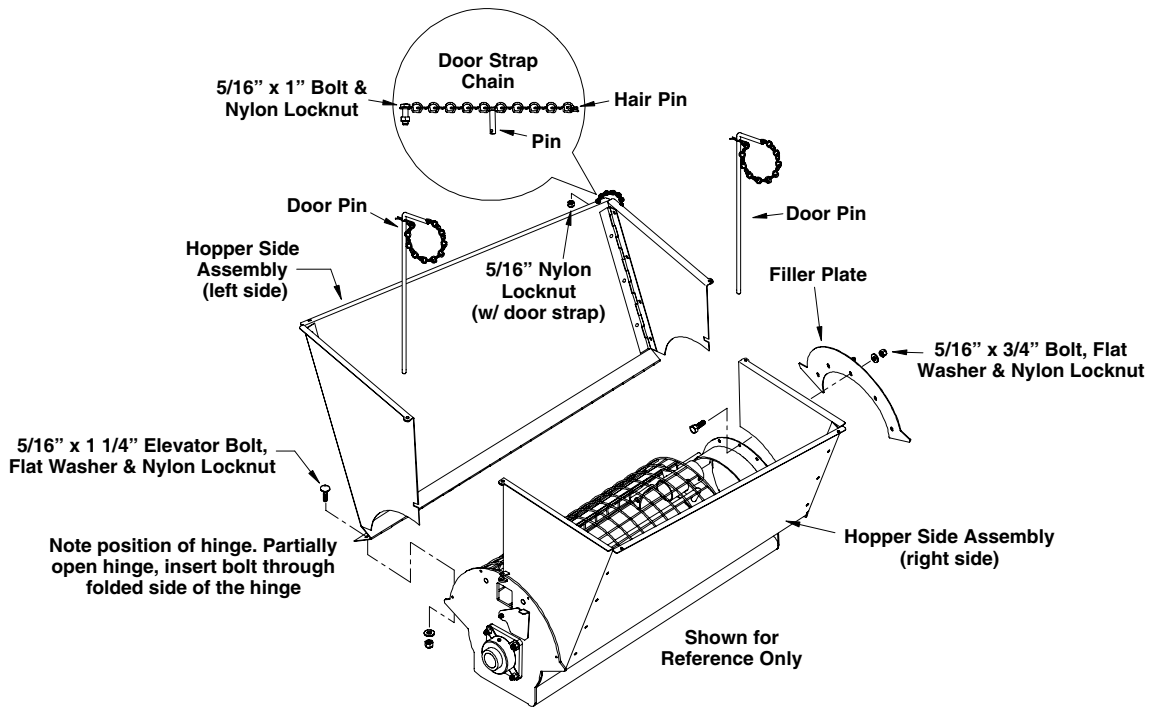

# ASSEMBLY INSTRUCTIONS

## INLET HOPPER ASSEMBLY (con't.)

**IMPORTANT!** When the hopper sides are extended, it is possible they could become damaged during transport, especially when turning tight corners. To prevent this, the hopper sides should be folded inward when the auger is to be transported. The sides can also be folded inward when storing the auger as well.

1. To fold the hopper sides, remove the long pins from the front and rear doors of the hopper. Fold the doors inward. The long pins will be stored on the doors in the same manner as when the hopper sides are extended, insert the pin through the hole at the top of the door panel and through the lower tab on the door, secure using the attached hairpin (see illustration below).
2. After the doors are folded inward, tilt the hopper sides towards the center of the inlet assembly and using the chain strap and pin, secure the hopper panels as shown in the illustration below.
3. Reverse these procedures to extend the hopper sides when setting up the auger for operation.

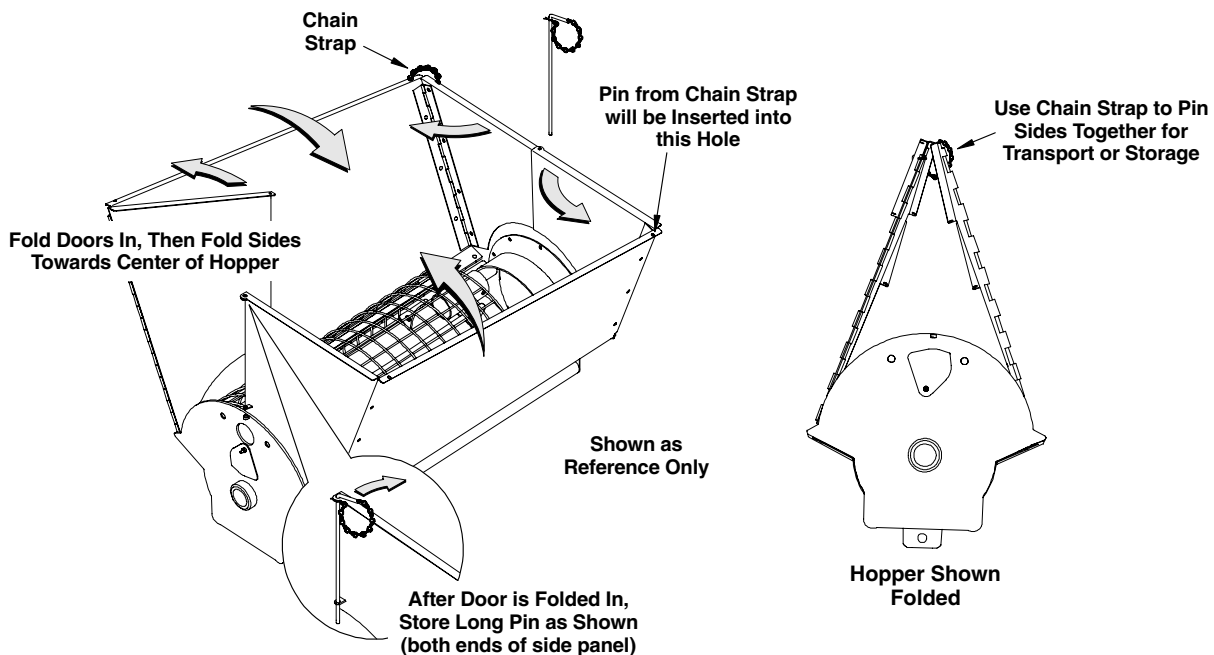

## OPTIONAL INLET HOPPER (FLEXIBLE)

1. Using 5/16" x 3/4" carriage bolts, flat washers and nylon locknuts, assemble the front, rear, left side & right side hopper panels together (See illustration below).  
Attach the hopper and back fill panel to the auger intake assembly using 5/16" x 3/4" carriage bolts, flat washers and nylon locknuts as shown in the illustration below (the back fill panel is positioned at the front of the hopper as shown below).  
Secure the front panel of the flex hopper to the auger intake assembly using 1/4" x 3/4" bolts, flat washers and nylon locknuts (See illustration below).
2. Position the rubber boot at the top of the flex hopper as shown in the illustration below. Attach the rubber boot to the inside of the hopper using the 1" x 40" (25 mm x 1.02 m) and 1" x 28" (25 mm x 71.1 cm) long clamp strips, and the 1/4" x 3/4" bolts, flat washers and nylon locknuts (the longer clamp strips are used to secure the sides, the shorter strip on the rear, flat washers over slotted holes on clamp strips).
3. Attach the support angles, upper clamp strips and corner clamps onto the top portion of the rubber boot. Position the support angles to the inside of the rubber boot, the clamp strips onto the outside of the boot and the corner clamps to the outside of the clamp strip, See illustration below.  
Secure the angles and clamp strips using 1/4" x 3/4" bolts, flat washers and nylon locknuts.

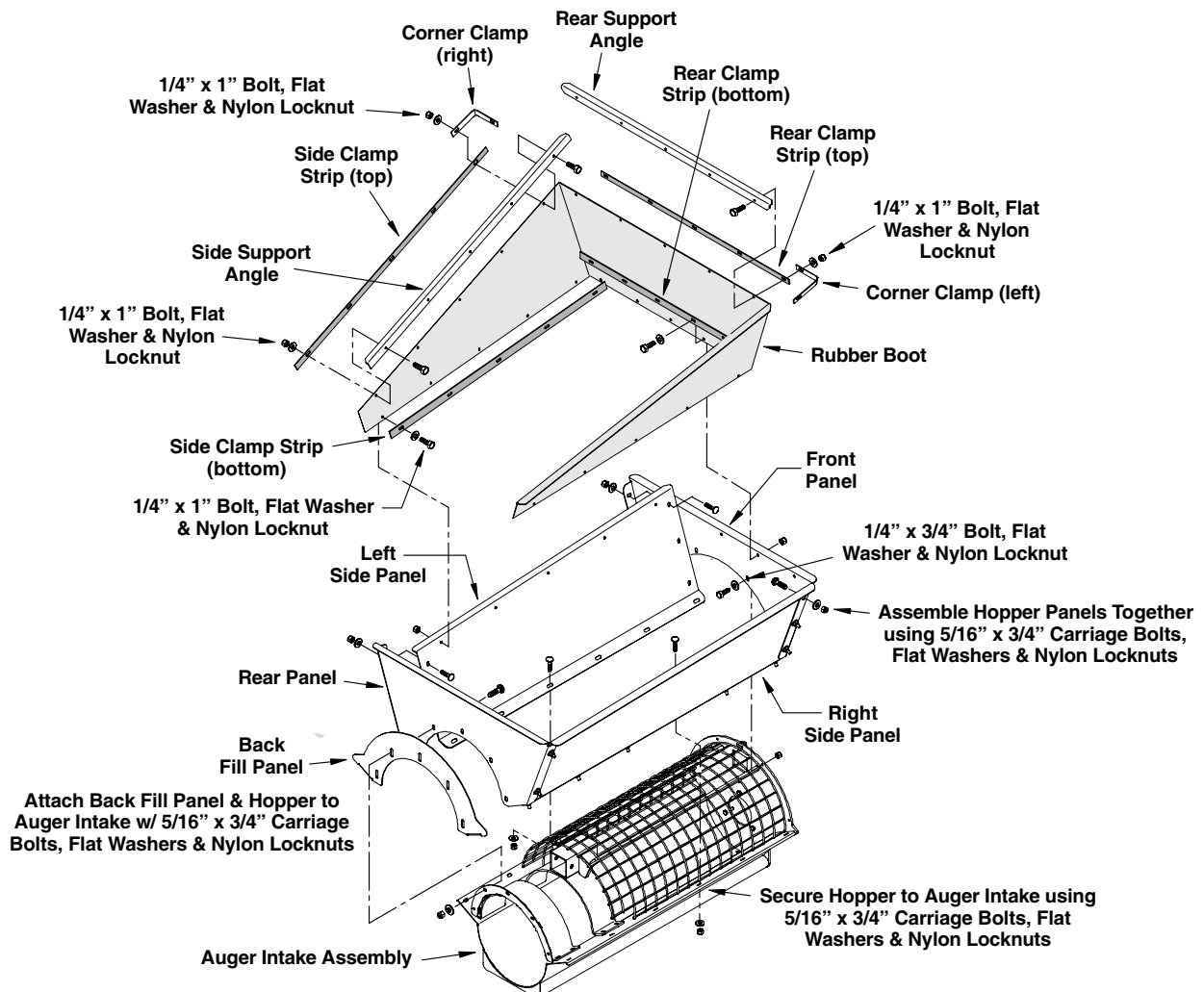

# ASSEMBLY INSTRUCTIONS

## **FLIGHT SECTION & HOUSING for UNITS with the OPTIONAL INTERNAL FLIGHT BEARINGS**

### **Install Flights & Internal Bearings**

Follow the auger assembly procedures as outlined on Pages 24 to 28. The connecting bands and drive shaft assembly will be the same as shown on those pages. The only difference will be the connection of the flight sections, refer to the following procedures for internal bearing and flight installation.

**Pages 60 & 61 show the layout sequence for drive shaft covers used with the internal bearing option.**

1. Slide an internal bearing hanger onto the end of the flight connecting stub. Apply anti-seize compound to the connecting stub and attach the flight to the next flight section. Secure using two 5/8" x 4" bolts (blk) and side depress locknuts (See Fig. 22).

NOTE: The flights are indexed to achieve a timed connection (a timed connection is where the flight pitch does not change across a connection, See Fig. 23).

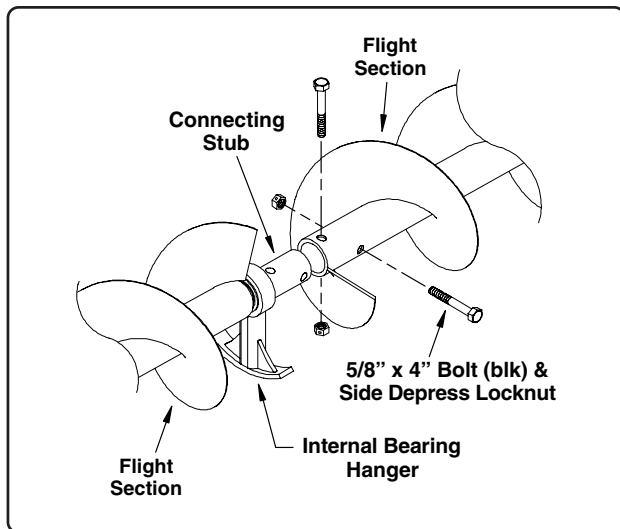

**Fig. 22**

2. Slide the tube sections and driveshafts together as outlined in the instructions on Page 28. After all tube and flight sections have been connected, the bearing hangers can be attached to the housing.

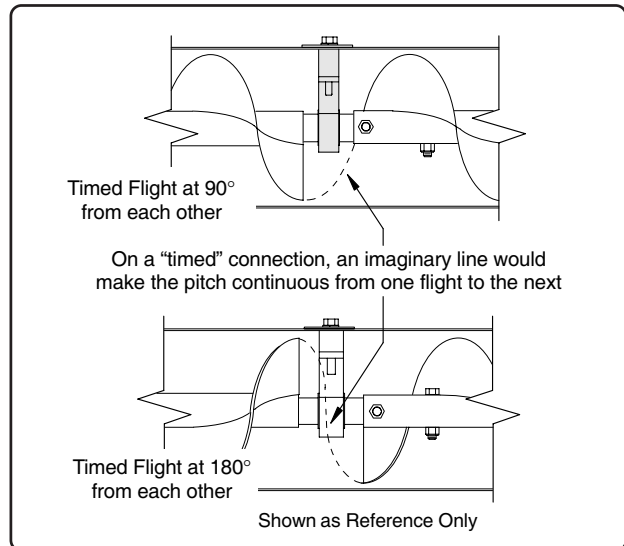

**Fig. 23**

3. A special "bearing positioning bar" has been provided to position the bearing hangers for assembly.

Insert the end of the positioning bar with the "double bend" through the slot in the top of the housing and hook the bearing hanger stem. Rotate the stem upward as far as possible (See Fig. 24).

Remove the positioning bar and insert the "L" shaped end into the slot. Hook the bearing hanger stem and pull upward to place the hanger in an upright position.

4. Position the bearing hanger so the mounting hole is visible through the slot in the housing.

Adjust the hanger so it is centered between the ends of the flights. (See Fig. 25). This can be done by sliding the hanger back and forth through the slot to determine approximate center (there should be equal distance between each end of the flight and bearing).

5. Secure the bearing hanger using one mounting plate and one 5/8" x 1 1/2" bolt and lock washer (See Fig. 26). Repeat these steps for all remaining flights and bearing hangers.

## INSTALL FLIGHTS & INTERNAL BEARINGS (con't.)

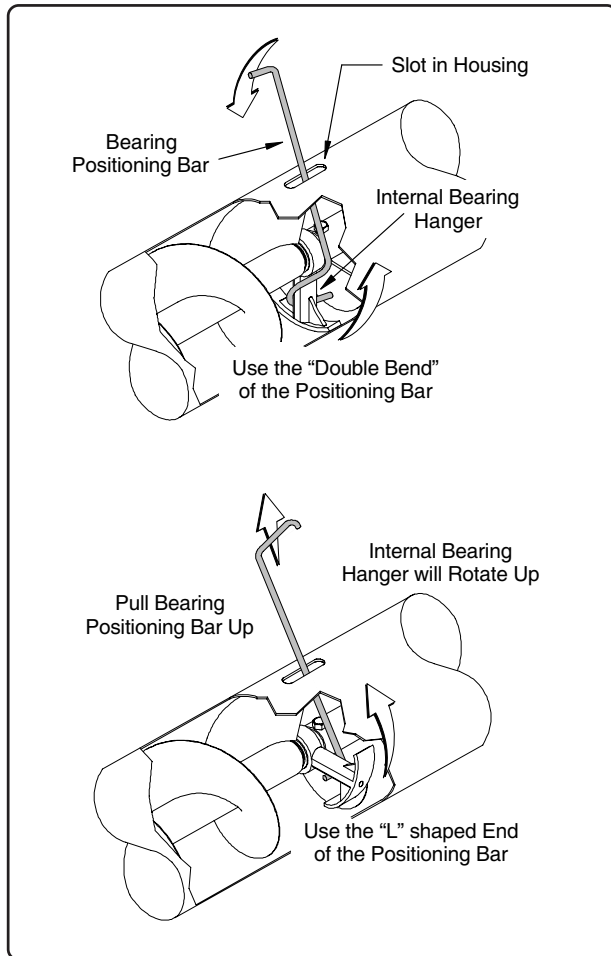

**Fig. 24**

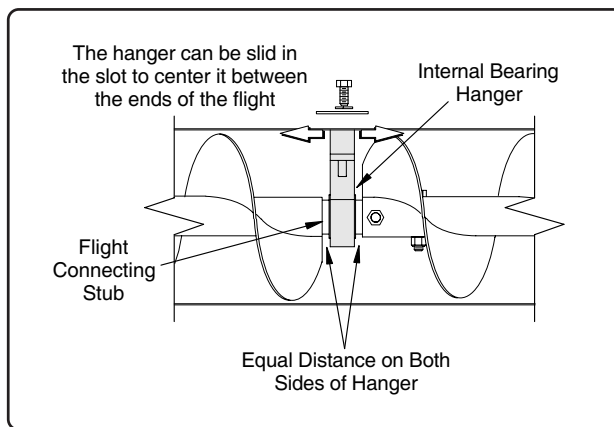

**Fig. 25**

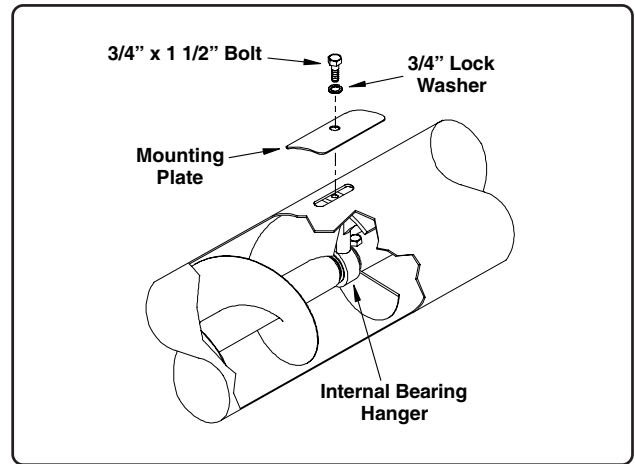

**Fig. 26**

### Remove Flights & Internal Bearings

Place the auger in the full down position. Raise and support the inlet end of the auger so the inlet end is a little higher than horizontal.

Page 33 shows the procedures for installation of the intake hopper. These instructions can be reversed to assist with the removal of the intake hopper.

1. Remove the intake hopper to expose the lower flight section. Disconnect the head flight shaft from the gearbox shaft at the discharge end of the auger.
2. Remove and retain the bolts and mount plates securing the hanger bearings to the auger housing.
3. Pull the flight sections out of the auger. As each flight connection clears the auger housing, disconnect the flights from each other and remove the bearing hanger.
4. Replace the damaged bearing hanger and reinstall the flights and hangers. Refer to the instructions on Page 58 for flight and bearing hanger installation. Reinstall the intake hopper and verify all hardware is tight and all parts are properly secured and in place.

### Install Drive Shaft Covers

The drive shaft cover mounting procedure for augers with optional internal bearings will be the same as shown on Page 44.

Refer to the illustrations on Pages 60 & 61 for drive shaft cover identification and sequence of assembly for units with internal bearings.

# ASSEMBLY INSTRUCTIONS

## DRIVESHAFT COVER INSTALLATION

### F/ INTERNAL BEARING OPTION

#### PTO DRIVE MODELS

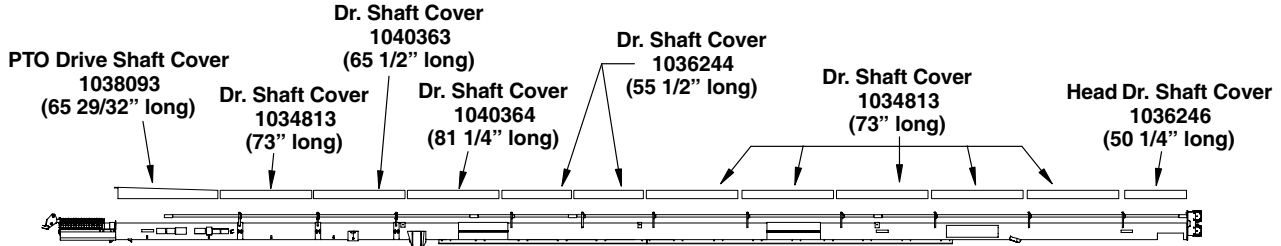

**72' PTO Drive Models  
w/ Internal Bearings**

All Drive Shaft Covers are Secured with 1/4" x 3/4" Self Tapping Screws, Except PTO Shaft Cover to Gearbox, it Attaches with the PTO Gearbox U-Joint Shield & uses 1/2" x 3/4" bolts

<b>Driveshaft Cover Sequence</b>	1 ea. - 1038093	65 29/32" long
<b>Beginning at Intake End</b>	1 ea. - 1034813	73" long
<b>72' PTO Drive Models</b>	1 ea. - 1040363	65 1/2" long
<b>w/ Internal Bearings</b>	1 ea. - 1040364	81 1/4" long
	2 ea. - 1036244	55 1/2" long
	5 ea. - 1034813	73" long
	1 ea. - 1036246	50 1/4" long

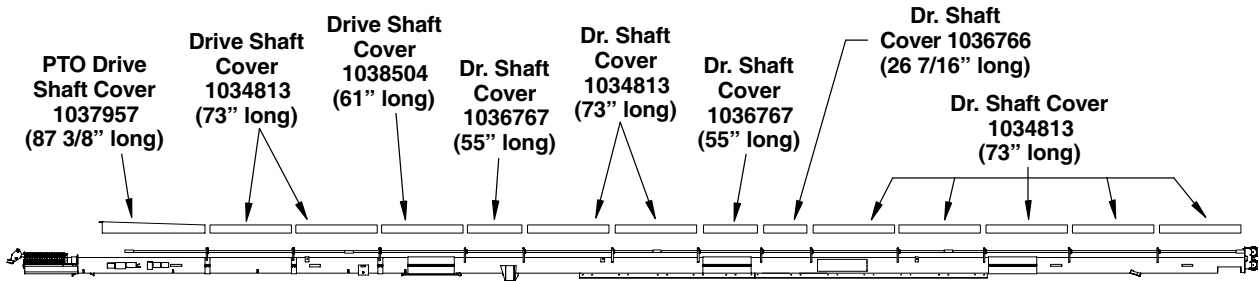

**82' PTO Drive Models  
w/ Internal Bearings**

All Drive Shaft Covers are Secured with 1/4" x 3/4" Self Tapping Screws, Except PTO Shaft Cover to Gearbox, it Attaches with the PTO Gearbox U-Joint Shield & uses 1/2" x 3/4" bolts

<b>Driveshaft Cover Sequence</b>	1 ea. - 1037957	87 3/8" long
<b>Beginning at Intake End</b>	2 ea. - 1034813	73" long
<b>82' PTO Drive Models</b>	1 ea. - 1038504	61" long
<b>w/ Internal Bearings</b>	1 ea. - 1036767	55" long
	2 ea. - 1034813	73" long
	1 ea. - 1036767	55" long
	1 ea. - 1036766	26 7/16" long
	5 ea. - 1034813	73" long

## DRIVESHAFT COVER INSTALLATION

### F/ INTERNAL BEARING OPTION

### F/ ELECTRIC DRIVE MODELS

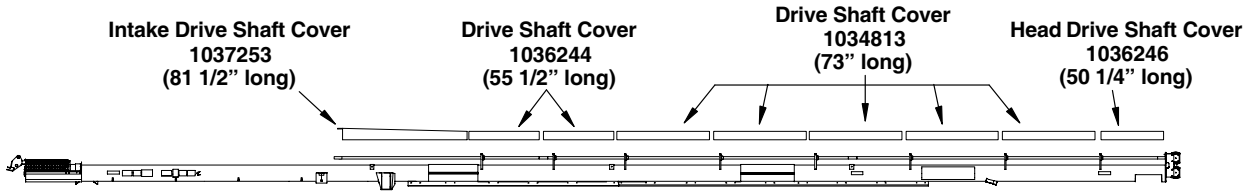

**72' Electric Drive Models  
w/ Internal Bearings**

All Drive Shaft Covers are Secured with 1/4" x 3/4" Self Tapping Screws,  
Except Drive Shaft Cover to Gearbox, it uses 1/2" x 3/4" bolts

<b>Driveshaft Cover Sequence</b>	1 ea. - 1037253	81 1/2" long
<b>Beginning at Intake End</b>	2 ea. - 1036244	55 1/2" long
<b>72' Electric Drive Models</b>	5 ea. - 1034813	73" long
<b>w/ Internal Bearings</b>	1 ea. - 1036246	50 1/4" long

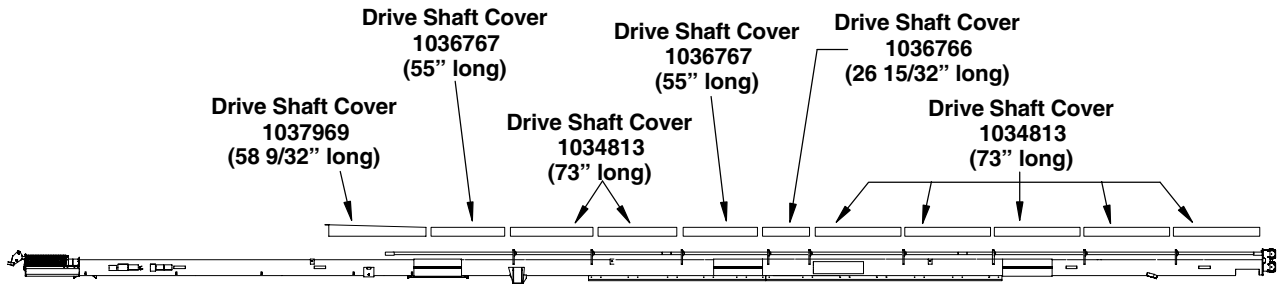

**82' Electric Drive Models  
w/ Internal Bearings**

All Drive Shaft Covers are Secured with 1/4" x 3/4" Self Tapping Screws,  
Except Drive Shaft Cover to Gearbox, it uses 1/2" x 3/4" bolts

<b>Driveshaft Cover Sequence</b>	1 ea. - 1037969	58 9/32" long
<b>Beginning at Intake End</b>	1 ea. - 1036767	55" long
<b>82' Electric Drive Models</b>	2 ea. - 1034813	73" long
<b>w/ Internal Bearings</b>	1 ea. - 1036767	55" long
	1 ea. - 1036766	26 15/32" long
	5 ea. - 1034813	73" long

# PARTS LIST TABLE OF CONTENTS

**Box of Parts Information ..... P-1**

**Decals and Safety Signs ..... P-2 to P-3**

**Main Auger Components ..... P-4 to P-5**

- Lower, Mid & Upper Tube & Flight Sections, 72' Models ..... P-4
- Connecting Bands ..... P-4
- Track Sections, 72' Models ..... P-4
- Track Sections 82' Models ..... P-5
- Lower, Mid & Upper Tube & Flight Sections, 82' Models ..... P-5

**Hydraulic Components ..... P-5**

**Truss Components ..... P-6**

**PTO Driveline, Intake Screen, Jack, Gearbox, Hitch ..... P-7**

**Driveshaft, Driveshaft Covers, PTO Drive Models ..... P-8**

**Driveshaft, Driveshaft Covers, Electric Drive Models ..... P-9**

**Electric Drive Components ..... P-10 to P-11**

**Winch Lift Components ..... P-12**

**Electric Winch Components ..... P-13**

**Undercarriage ..... P-14 to P-15**

**Collapsible Axle, 82' Models ..... P-15**

**Trolley Components ..... P-16**

**Head Gearbox Components ..... P-17**

**Collapsible Hopper Components ..... P-18**

**Flex Hopper Components ..... P-19**

**Internal Bearing Components ..... P-20 to P-23**

**Torque Chart ..... P-24**

# PARTS LIST

## 13" Portable Top Drive Auger 72' & 82' Models

Each Model is shipped with a **Main Box of Parts**. Each "Main Box of Parts" contains a box of parts for each of the auger groups shown below.

### Main Box of Parts

13" x 72' - 1054101

### Grouped Box of Parts

72' Undercarriage - 1045454

72' Main Auger Tube - 1054292

### Main Box of Parts

13" x 72' w/ Internal Bearings- 1054323

### Grouped Box of Parts

72' Undercarriage - 1045454

72' Main Auger Tube - 1054328

### Main Box of Parts

13" x 82' - 1054102

### Grouped Box of Parts

82' Undercarriage - 1045473

82' Main Auger Tube - 1054294

### Main Box of Parts

13" x 82' w/ Internal Bearings- 1054324

### Grouped Box of Parts

82' Undercarriage - 1045473

82' Main Auger Tube - 1054329

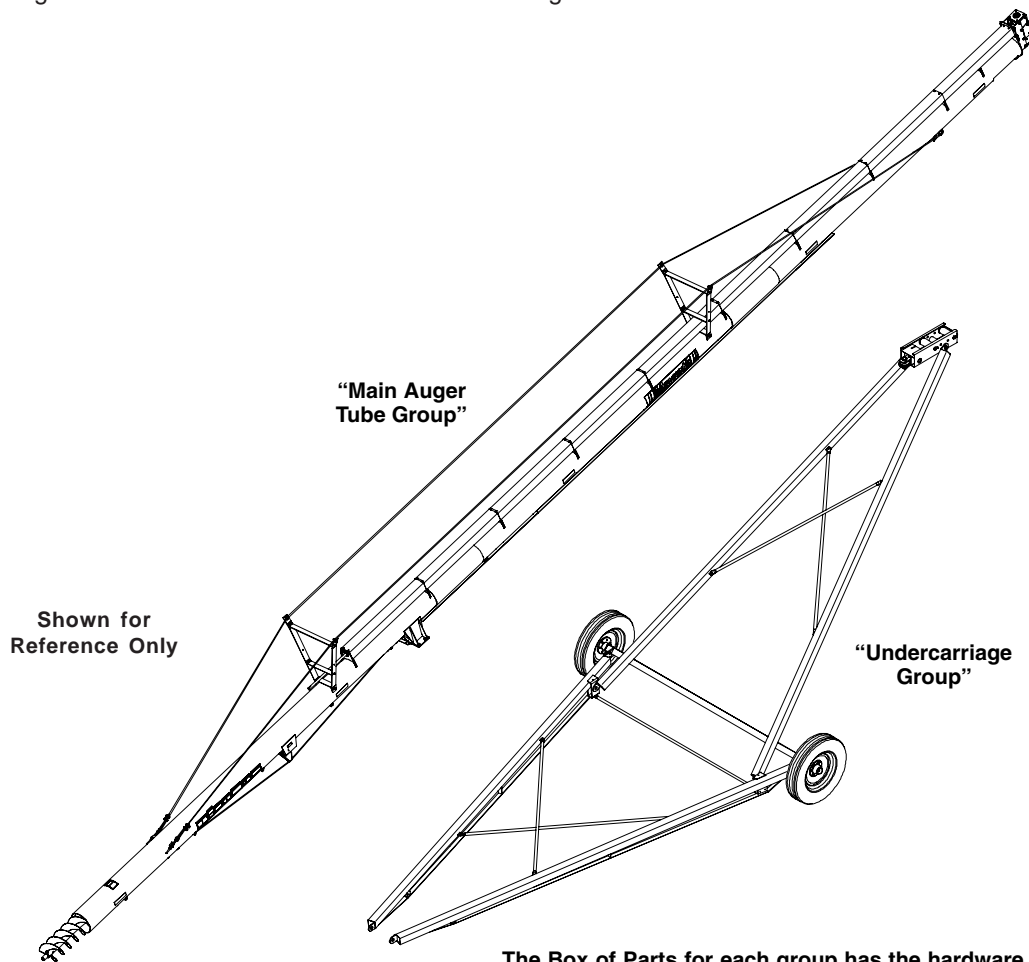

The Box of Parts for each group has the hardware and components used to assemble that specific group

# PARTS LIST

## DECALS & SAFETY SYMBOLS

13" Top Drive Augers  
72' and 82' Models

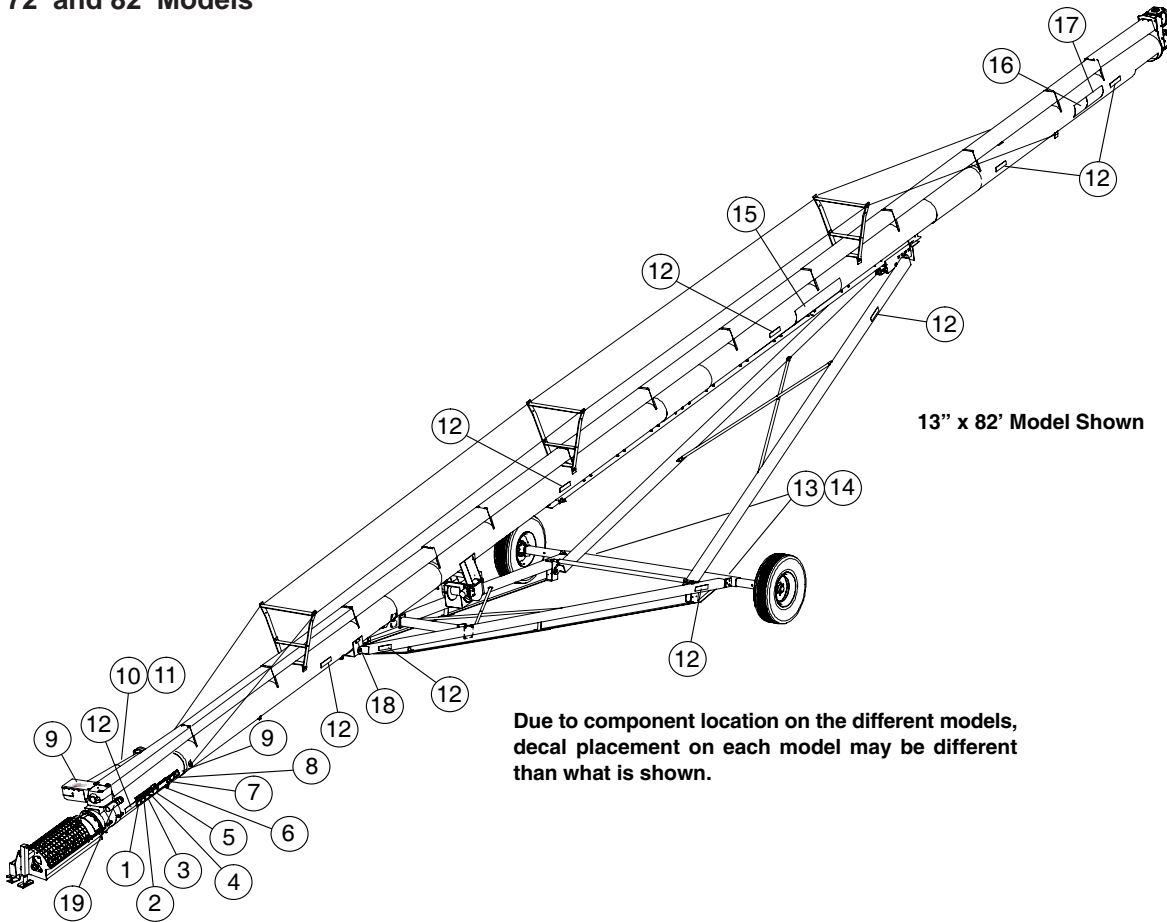

Due to component location on the different models, decal placement on each model may be different than what is shown.

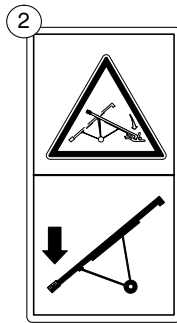

Ref. No.	Part No.	Description	Ref. No.	Part No.	Description
1	1025078	Decal, Danger, Power Line Hazard	3	1025080	Decal, Danger, Rotating Auger
2	1025079	Decal, Danger, Upending Hazard	4	1025082	Decal, Danger, Rotating Shaft

## DECALS & SAFETY SYMBOLS

### 13" Top Drive Augers 72' and 82' Models

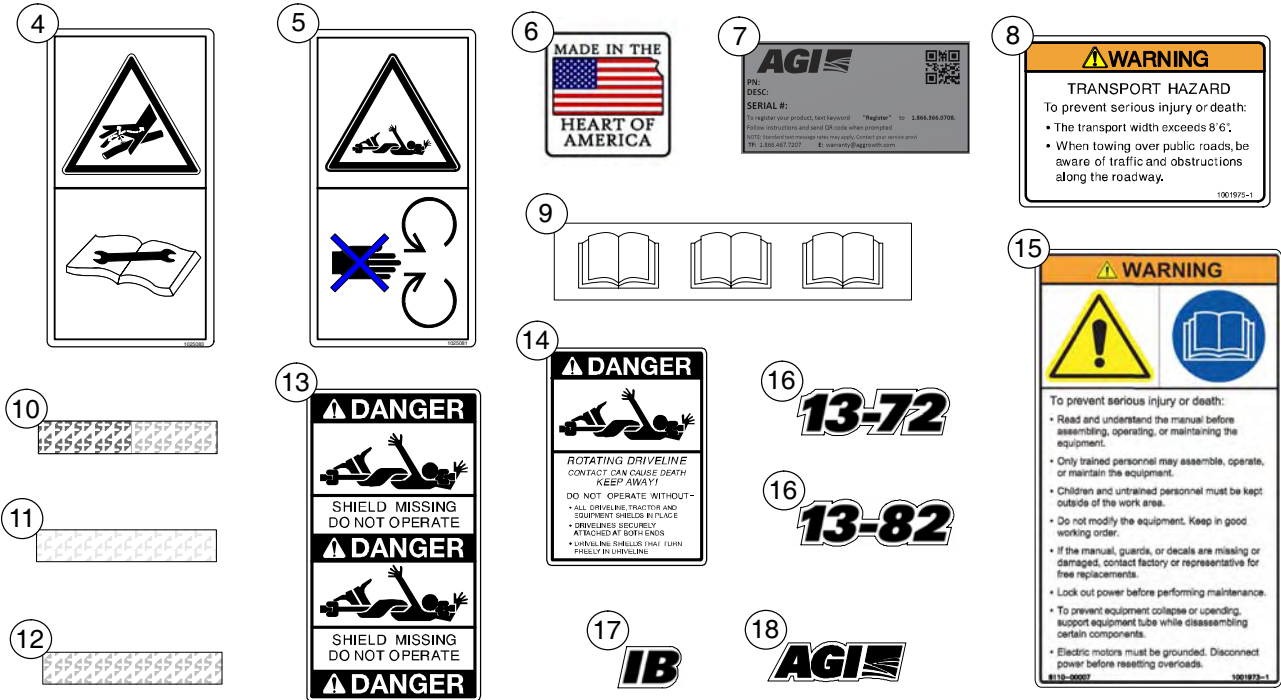

Ref. No.	Part No.	Description	Ref. No.	Part No.	Description
5	1025083	Decal, Danger, Escaping Hydraulic Oil	15	1001973-1	Decal, Caution, General Information
6	1041833	Decal, U.S. Flag	16	1054000	Decal, 13-72
7	34678-1	Serial No. Plate	(16)	1054001	Decal, 13-82
8	1001975-1	Decal, Warning, Transport Width	17	1054003	Decal, "IB" f/ 13" Tube
9	1004461	Decal, Operator's Manual Inside	18	1054030	Decal, AGI
10	1021181	Decal, Red/Orange Reflective	*	1054062	Kit, Decal AGI 13-72
11	1021180	Decal, Yellow Reflective	*	1054063	Kit, Decal AGI 13-82
12	1021179	Decal, Red Retroreflective	*	1054009	Kit, Decal AGI 13-72 IB
13	13-10021	Decal, Danger, Shield Missing	*	1054010	Kit, Decal AGI 13-82 IB
14	13-10022	Decal, Danger, Rotating Driveline			* Not Shown

Decal Kits contain the respective auger size decal (13-72, 13-82), the IB decal (if applicable), the AGI decal, a manual for application instructions and an applicator for applying the decals.

# PARTS LIST

## MAIN AUGER COMPONENTS

### 13" x 72' Top Drive Models

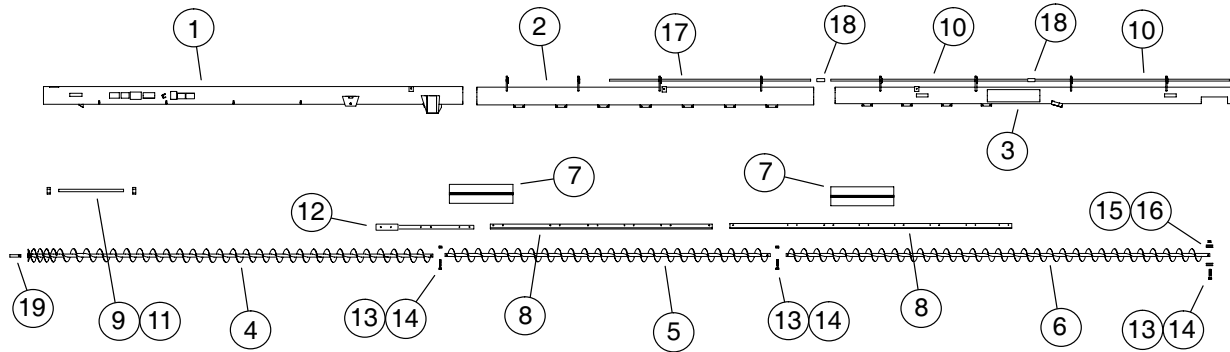

Ref. No.	Part No.	Description	Ref. No.	Part No.	Description
1	1036206-130	Lower Tube Section f/ 72'	9	D1152	Nut, 3/4-10 Non-lock
2	1040031-130	Mid Tube Section f/ 72'	10	1040030	Drive Shaft, 150" long
3	1054276 130	Head Tube Section f/ 72' (25' long)	11	1036432	Intake Screen Tensioner Rod
4	1038051P	Lower Flight, 1/4" (27'-1" long)	12	1038075	Track Stiffener
5	1021253P	Mid Flight, 1/4" (20'-0" long)	13	1010485	Bolt, 5/8-11 x 4" (G8 BLK)
6	1036657P	Head Flight, 1/4" (25'-0" long)	14	1005111	Locknut, 5/8-11 (side depress)
7	1033444	Connecting Band, 13"	15	33026	Washer, 5/8" Flat (PLT)
8	1036230	Lower Track, RH f/ 72' (123 11/16" long)	16	1022476	Washer, Rubber (5/8" x 1 3/4" o.d. x 1/4" thick)
(8)	1036229	Lower Track, LH f/ 72' (123 11/16" long)	17	1040035	Drive Shaft, 141 1/4" long
(8)	1036228	Upper Track, RH f/ 72' (240" long)	18	1036076	Coupler, 2 1/4" dia. x 5" long w/ snap ring
(8)	1036227	Upper Track, LH f/ 72' (240" long)	(18)	1036078	Key, 3/8" sq, x 2 1/2" long
			19	1259D	Stub Shaft f/ Intake

# PARTS LIST

## MAIN AUGER COMPONENTS

### 13" x 82' Top Drive Models

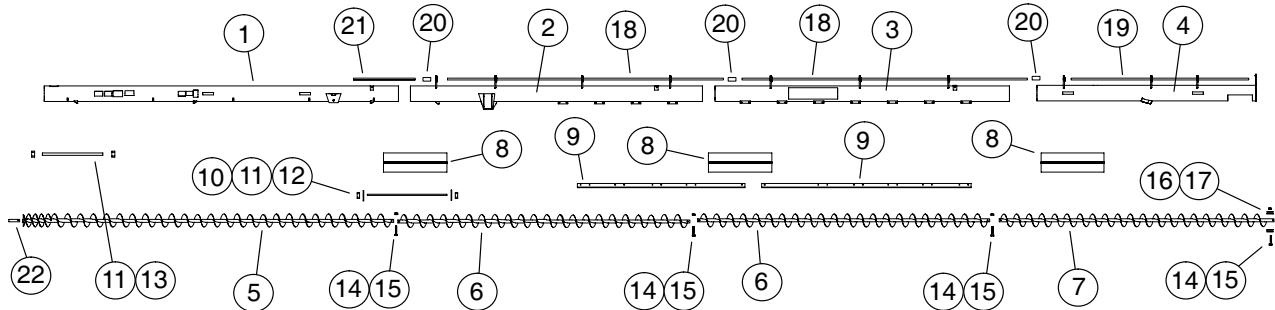

Ref. No.	Part No.	Description	Ref. No.	Part No.	Description
1	1034801-130	Lower Tube Section f/ 82'	12	33027	Flat Washer, 3/4"
2	1054554-130	Lower Mid Tube Section f/ 82'	13	1036432	Intake Screen Tensioner Rod
3	1034803-130	Upper Mid Tube Section f/ 82'	14	1010485	Bolt, 5/8-11 x 4" G8 BLK
4	1054277-130	Head Tube Section f/ 82' (15' long)	15	1005111	Locknut, 5/8-11 (side depress)
5	1038051P	Lower Flight, 1/4" (27'-5" long)	16	33026	Flat Washer, 5/8" PLT
6	1021253P	Mid Flight, 1/4" (20'-0" long)	17	1022476	Washer, Rubber (5/8" x 1 3/4" o.d. x 1/4" thick)
7	1054284P	Head Flight, 1/4" (15'-5" long)	18	1034198	Drive Shaft, 240" long
8	1033444	Connecting Band, 13"	19	1054285	Drive Shaft, 154-3/4" long
9	1035849	Lower Track, RH, 233" long	20	1036076	Coupler, 2 1/4" dia. x 5" long w/ snap ring
(9)	1035848	Lower Track, LH, 233" long	(20)	1036078	Key, 3/8" sq, x 2 1/2" long
(9)	1036095	Upper Track, RH, 189" long	21	1054540	Drive Shaft, 51" long
(9)	1036096	Upper Track, LH, 189" long	22	1259D	Stub Shaft f/ Intake
10	1034234	Tensioner Rod (f/ 82' only)			
11	D1152	Nut, 3/4-10 Non-lock			

## HYDRAULIC COMPONENTS

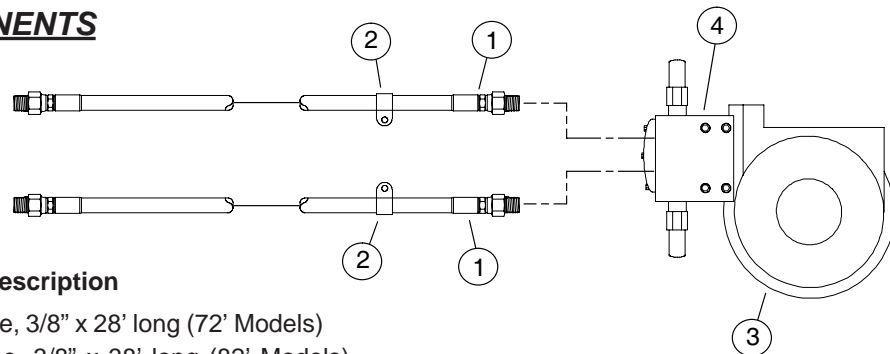

Ref. No.	Part No.	Description
1	1032436	Hydraulic Hose, 3/8" x 28' long (72' Models)
(1)	1032438	Hydraulic Hose, 3/8" x 38' long (82' Models)
2	1006324	Hydraulic Hose Mounting Clamp
3	1021162	Hydraulic Winch (less relief valve and covers)
4	1032392	Bypass Relief Valve

# PARTS LIST

## TRUSS COMPONENTS

### 13" x 72' and 13" x 82' Top Drive Models

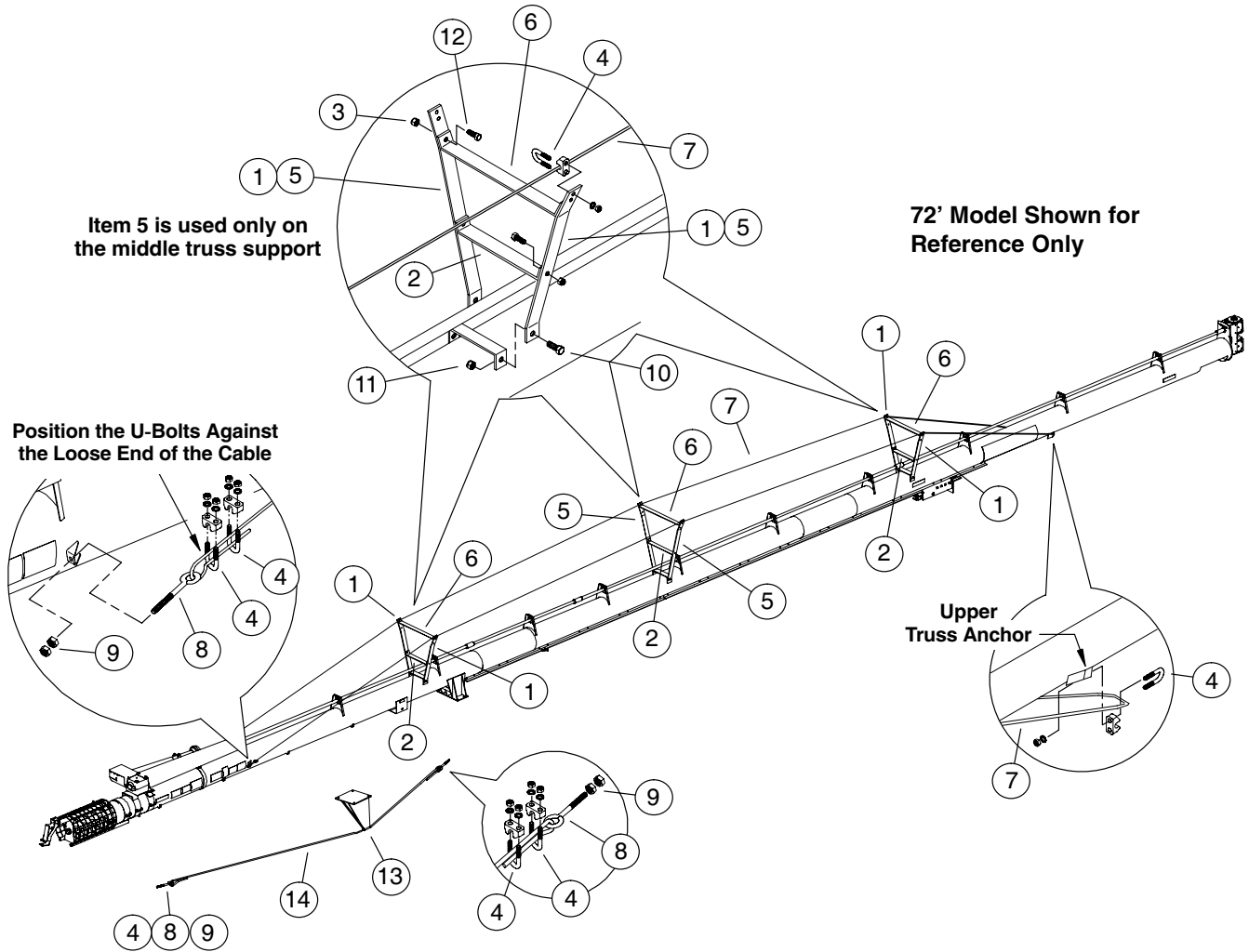

Ref. No.	Part No.	Description
1	1038054	Truss Side (40 1/2" long)
2	1019157	Truss Crossbrace, lower (18 1/4" long)
3	33136	Nut, 3/8-16 Nylon Lock PLT
4	1021158	Cable Clamp, 1/2"
5	1037940	Truss Side (43 1/2") f/ 72' & 82' Models
6	1031864	Truss Crossbrace, top (30" long) f/ 72' Models
(6)	1038363	Truss Crossbrace, top (32" long) f/ 82' Models
7	1038068	Cable, 1/2" x 117' f/ 72' Models
(7)	1038053	Cable, 1/2" x 142' f/ 82' Models

Ref. No.	Part No.	Description
8	866015-1	Eyebolt, 5/8"
9	D1150	Nut, 5/8-11, Non-lock
10	33276	Bolt, 5/8-11 x 1 1/2" G5 PLT
11	33139	Nut, 5/8-11 Nylon Lock PLT
12	33229	Bolt, 3/8-16 x 1 1/4" G5 PLT
13	1037630	Under Truss Tower
14	1038069	Cable, Under Truss Tower f/ 72' Models (14'-3" long)
(14)	1037970	Cable, Under Truss Tower f/ 82' Models (21'-2" long)

# PARTS LIST

## PTO DRIVELINE, INTAKE SCREEN, JACK, GEARBOX & HITCH

All items shown are used on the  
13" Top Drive 72' and 82' Models

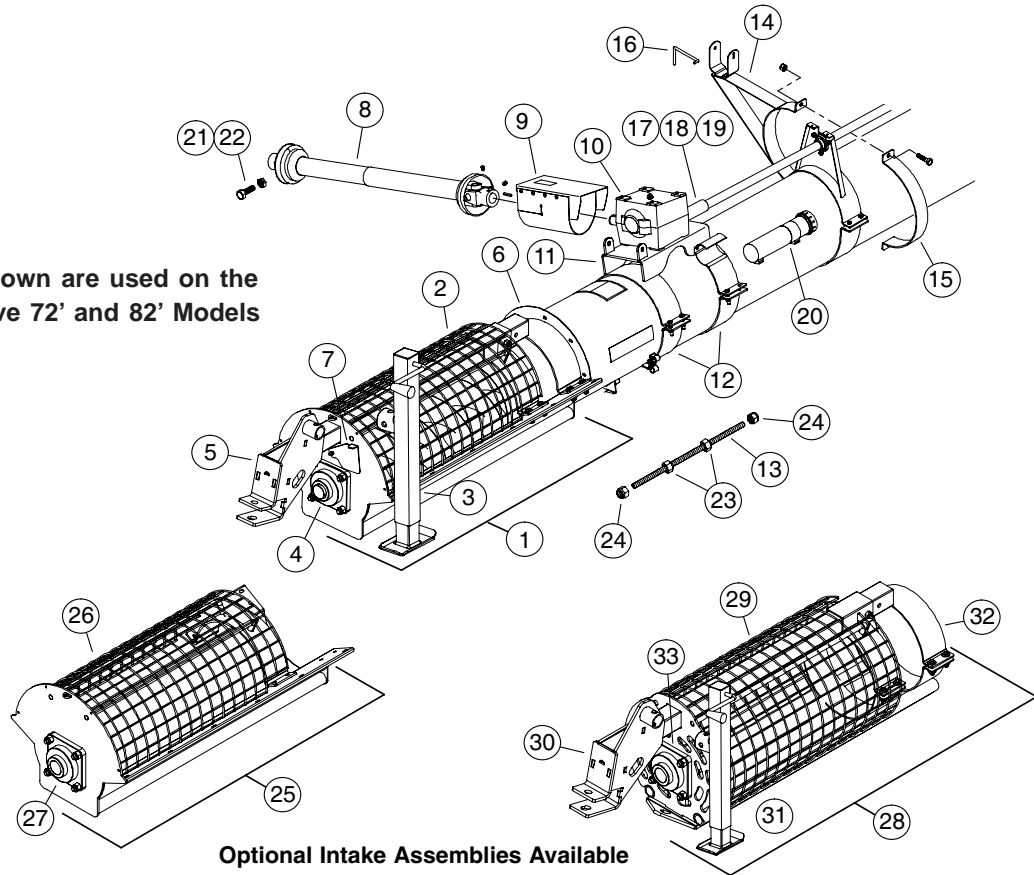

Optional Intake Assemblies Available

Ref. No.	Part No.	Description	Ref. No.	Part No.	Description
1	1054141	Intake Ay, (Portable Inline Style)	17	1036076PTD	Coupler, Drive Shaft w/ Snap Ring
2	1054142	•Intake Weldment (Portable Inline Style)	18	1036078	Key, 3/8" sq. x 2 1/2" long
3	1036623	•Jack Assembly	19	1038D	Key, 3/8" sq. x 2" long
4	2214C	•Bearing, 2" bore 4-hole flange	20	1036990	Cannister, Operator's Manual
5	1043217	•Hitch (portable styles only)	21	1018891	Shear Bolt, 3/8-16 x 1" G8
6	1051078	•Half-Band Clamp f/ Intake	22	1004783	3/8-16 Locknut (side depress)
7	1043226	•Cover, Hitch Tube	23	D1152	Nut, 3/4-10 Non-Lock
8	1021297	PTO Driveline	24	33140	Nut, 3/4-10 Nylon Lock
9	1036150	PTO U-Joint Cover	25	1054296	Intake Ay. (Stationary Inline Style)
10	1021282	Gearbox, PTO	26	1054297	•Intake Weldment
11	1036125	Gearbox Mount	27	2214C	•Bearing, 2" bore 4-hole flange
12	1032114P	Half-Band f/ Gearbox Mount	28	1054336	Intake Ay. (Portable Cage Style)
13	1036432	Tensioner Rod 3/4"-10 x 20" lg	29	1054337	•Intake Weldment
14	1021312	Cradle f/ PTO Drive Line	30	1043217	•Hitch (portable styles only)
15	1021311	Half-Band f/ PTO Cradle	31	1036623	•Jack Assembly
16	3338A1	Pin, Cradle	32	1032114P	•Half-Band f/ Gearbox Mount
			33	2214C	•Bearing, 2" bore 4-hole flange

•Indented Parts Names Indicate these Parts are Included in the Previous Assembly.

# PARTS LIST

## DRIVE SHAFTS & DRIVE SHAFT COVERS

### PTO Drive Models

#### 72' PTO Drive Models

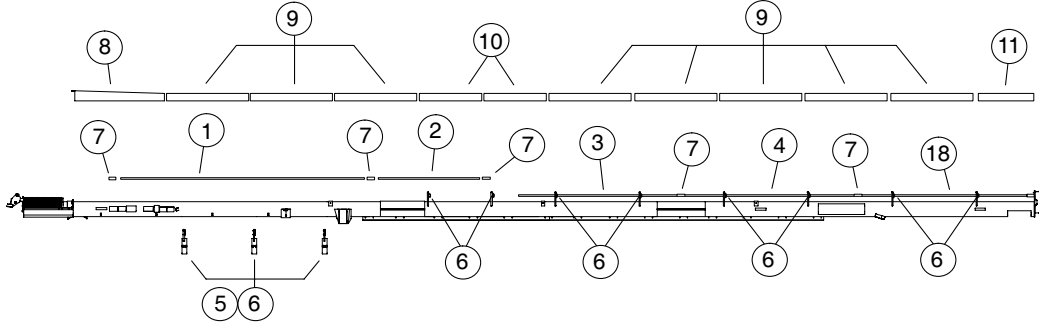

#### 82' PTO Drive Models

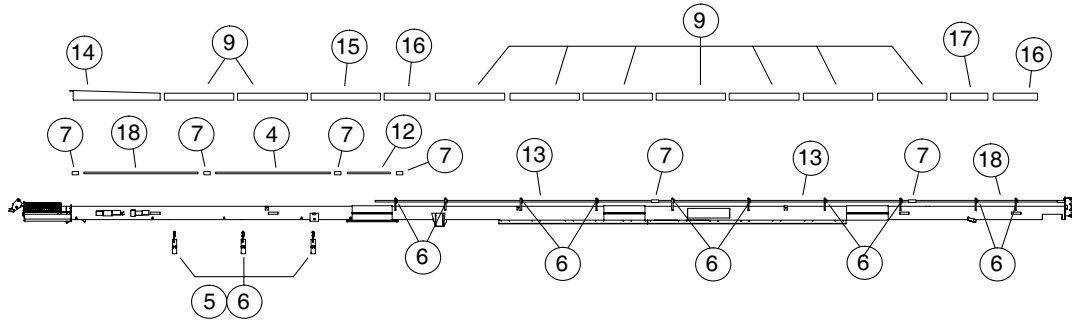

All items listed are used on the 72' and 82' Models unless otherwise noted.

Ref. No.	Part No.	Description	Ref. No.	Part No.	Description
1	1034818	Drive Shaft, 200 1/8" long	11	1036246	Cover, Drive Shaft f/ 72' Models (50 1/4" long)
2	1040030	Drive Shaft, f/ 72' Models (150" long)	12	1054540	Drive Shaft, f/ 82' Models (51" long)
3	1040035	Drive Shaft, f/ 72' Models (141 1/4" long)	13	1034198	Drive Shaft, f/ 82' Models (240" long)
4	1040440	Drive Shaft, (82 13/16" long)	14	1037957	Cover, PTO Shaft, f/ 82' Models (87 3/8" long)
5	1037420	Band-On Bearing Mount	15	1038504	Cover, Drive Shaft f/ 82' Models (61" long)
6	40206	Flangette Bearing	16	1035858	Cover, Drive Shaft, f/ 82' Models (49" long)
	40207	•Bearing, Flangette w/ lock collar	17	1034814	Drive Shaft, f/ 82' Models (39" long)
	40208	•Flangette f/ Bearing, 1 1/2" bore	18	1054285	Drive Shaft, f/ 82' Models (154 3/4" long)
7	1036076	Coupler, 2 1/4" dia. x 5" long w/ snap ring			
(7)	1036078	Key, 3/8" sq. x 2 1/2" long			
8	1038093	Cover, Drive Shaft f/ 72' Models (66" long)			
9	1034813	Cover, Drive Shaft (73" long)			
10	1036244	Cover, Drive Shaft, f/ 72' Models (55 1/2" long)			

• Indented Parts Names Indicate these Parts are Included in the Previous Assembly.

# PARTS LIST

## DRIVE SHAFTS & DRIVE SHAFT COVERS

### Electric Drive Models

#### 72' Electric Drive Models

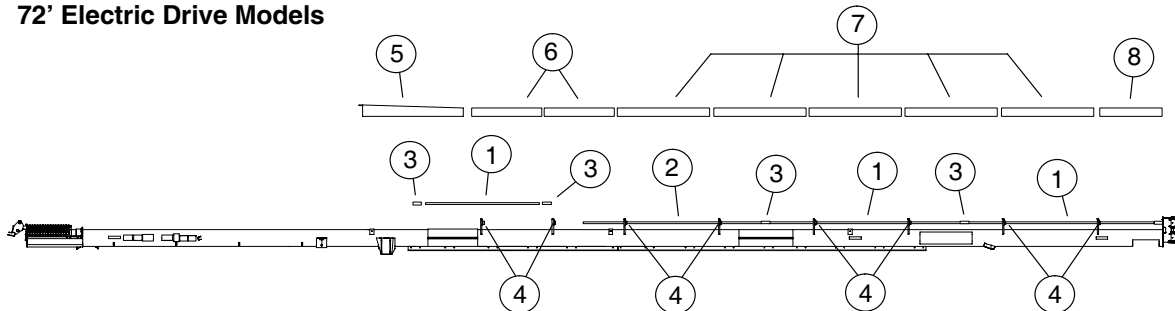

#### 82' Electric Drive Models

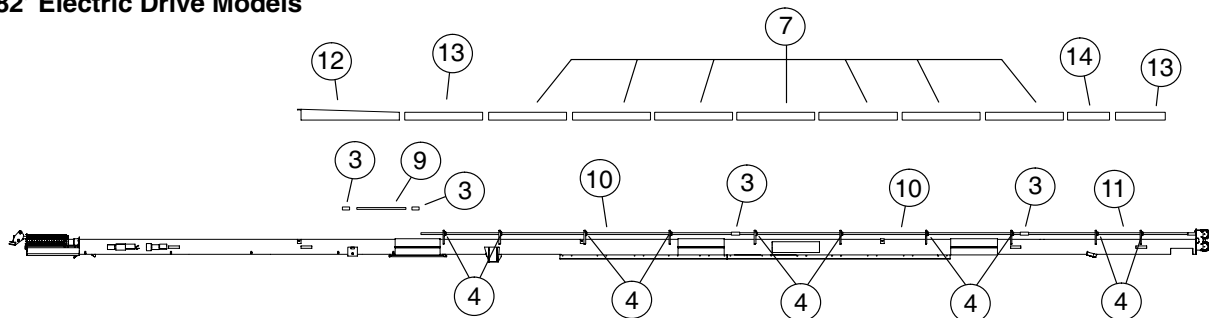

All items listed are used on the 72' and 82' Models unless otherwise noted.

Ref. No.	Part No.	Description	Ref. No.	Part No.	Description
1	1040030	Drive Shaft, f/ 72' Models (150" long)	8	1036246	Cover, Drive Shaft, f/ 72' Models (50 1/4" long)
2	1040035	Drive Shaft, f/ 72' Models (141 1/4" long)	9	1040424	Drive Shaft, f/ 82' Models (56 5/8" long)
3	1036076	Coupler, 2 1/4" dia. x 5" long w/ snap ring	10	1034198	Drive Shaft, f/ 82' Models (240" long)
(3)	1036078	Key, 3/8" sq. x 2 1/2" long	11	1040030	Drive Shaft, f/ 82' Models (150" long)
4	40206	Flangette Bearing	12	1037969	Cover, Intake Shaft, f/ 82' Models (58 9/32" long)
	40207	•Bearing, Flangette w/ lock collar	13	1035858	Cover, Drive Shaft, f/ 82' Models (49" long)
	40208	•Flangette f/ Bearing, 1 1/2" bore	14	1034814	Cover, Drive Shaft, f/ 82' Models (39" long)
5	1037253	Cover, Drive Shaft f/ 72' Models (83 1/2" long)			
6	1036244	Cover, Drive Shaft, f/ 72' Models (55 1/2" long)			
7	1034813	Cover, Drive Shaft (73" long)			

•Indented Parts Names Indicate these Parts are Included in the Previous Assembly.

# PARTS LIST

## ELECTRIC DRIVE COMPONENTS

### 13" X 72' and 13" X 82' Top Drive Models

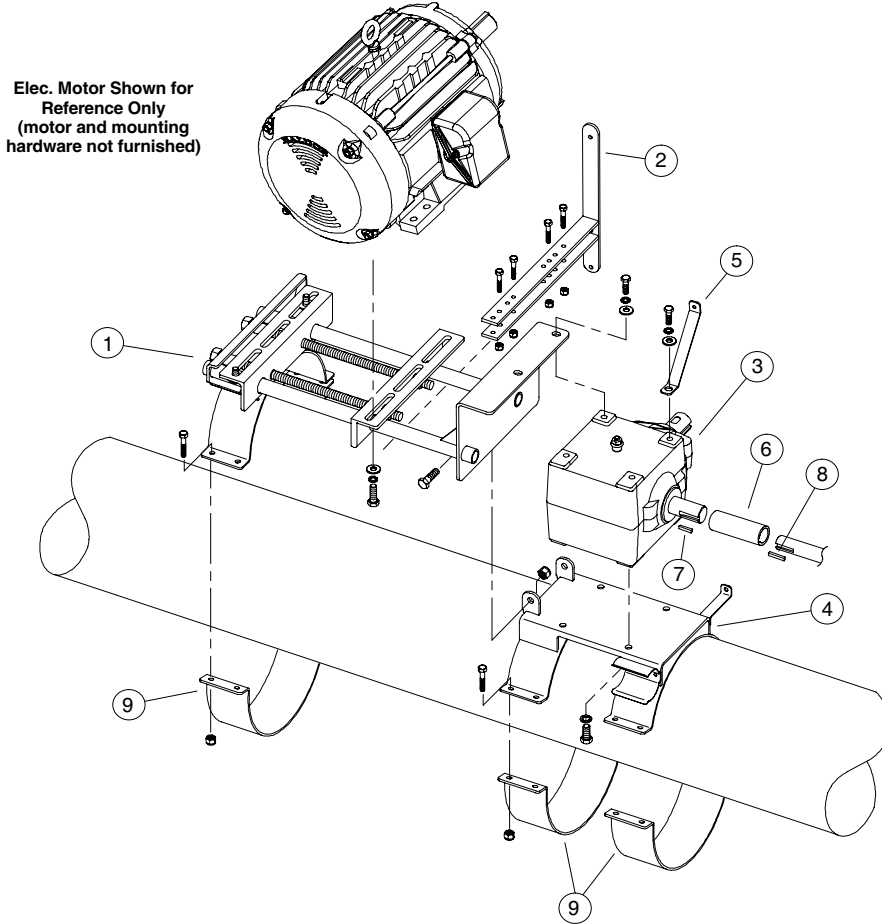

All items listed are used on the 72' and 82' Models

Ref. No.	Part No.	Description	Ref. No.	Part No.	Description
1	1037108	Motor Mount	6	1036076PTD	Coupler (gearbox to drive shaft)
2	1037240	Belt Guard Mount	7	1038D	Key, 3/8" sq. x 2" long
3	1021282	Gearbox, 1.875:1 ratio	8	1036078	Key, 3/8" sq. x 2 1/2" long
4	1036125	Gearbox Mount	9	1032114P	Half-Band, 13" x 4" wide
5	1037769	Belt Guard Brace			

## ELECTRIC DRIVE COMPONENTS

### 13" X 72' and 13" X 82' Top Drive Models

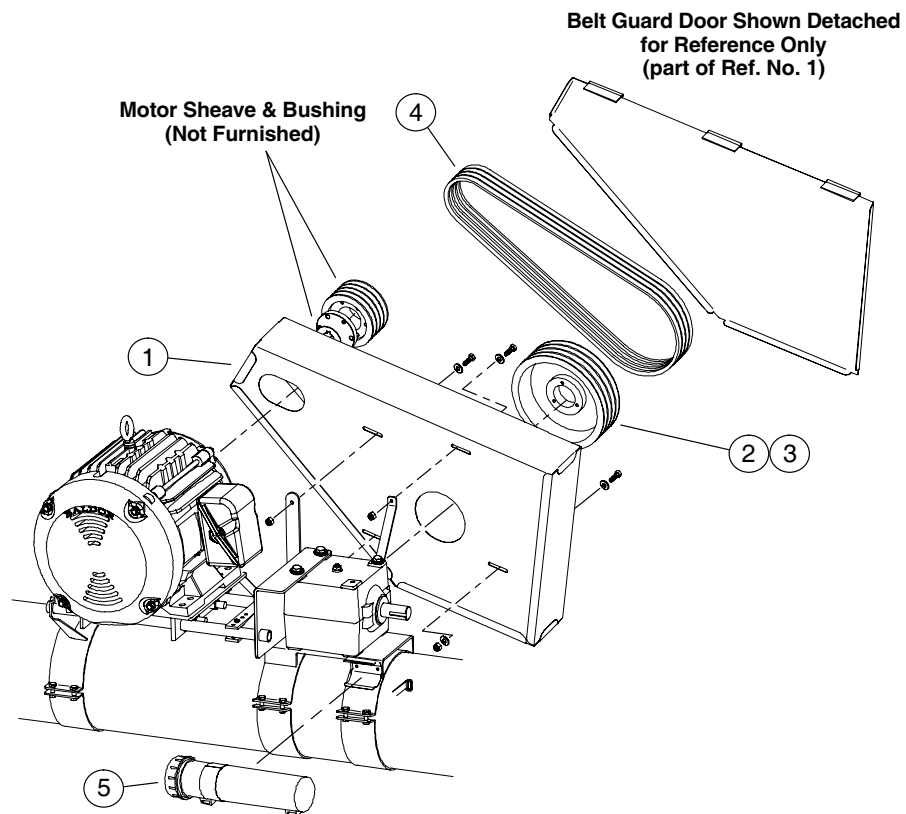

All items listed are used on the 72' and 82' Models

Ref. No.	Part No.	Description	Ref. No.	Part No.	Description
1	1037202	Belt Guard Weldment	5	1036990	Operators Manual Cannister
2	3091A1	Sheave, QD 12.4" 4-belt	--	1018308	Latch f/ Belt Guard*
3	1032857	Bushing, QD SK 1.75" bore			* Not Shown
4	40127	Belt, B75 V-belt			

# PARTS LIST

## WINCH LIFT COMPONENTS 72' & 82' TOP DRIVE MODELS

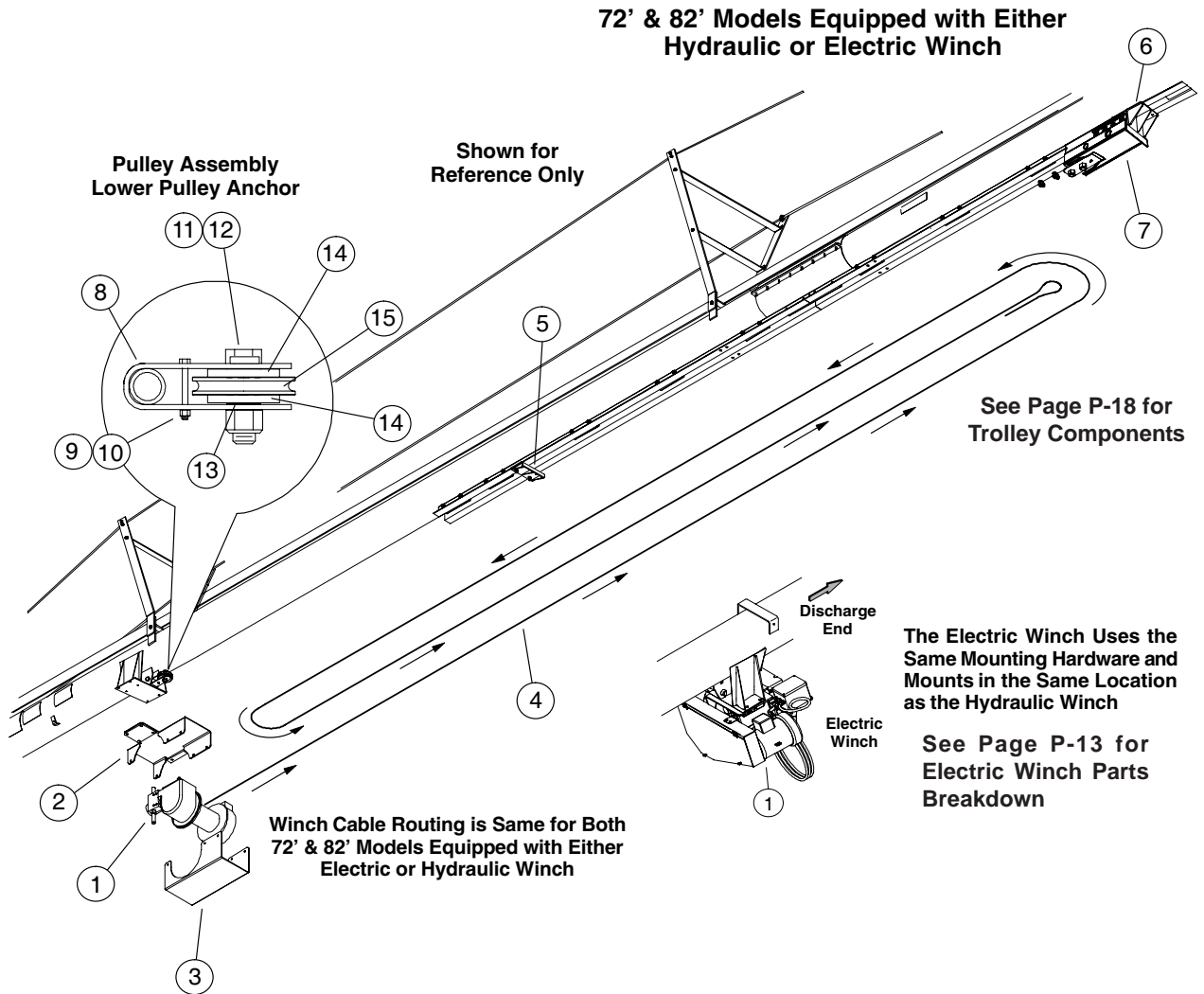

Ref. No.	Part No.	Description
1	1021069	Hydraulic Winch, Complete
(1)	1032553	Electric Winch, Complete
2	1021242	Upper Guard Half (hydr. winch)
3	1021237	Lower Guard Half (hydr. winch)
4	1038052	Cable, 1/2" dia. x 95'-6" lg (f/ 72' & 82' Models)
5	1031146	Trolley Stop, Lower
6	1019827	Trolley Stop, Upper
7	1021062	Trolley, Complete

Ref. No.	Part No.	Description
8	1021155	Clevis, Pulley
9	4619	Bolt, 1/4-20 x 2 1/2" G5 PLT
10	33150	Nut, 1/4-20 Nylon Lock PLT
11	1021064	Bolt, 1-8 x 4" G8 PLT
12	1007943	Nut, 1-8 Nylon Lock PLT
13	1021146	Bushing, Pulley/Anchor
14	1031583	Spacer, 3/8" f/ Trolley/Pulley
15	1021160	Pulley, f/ 1/2" Cable

# PARTS LIST

## ELECTRIC WINCH COMPONENTS 13" x 72' & 13" x 82' TOP DRIVE MODELS

Complete Winch Available: Order Part No. 1032553

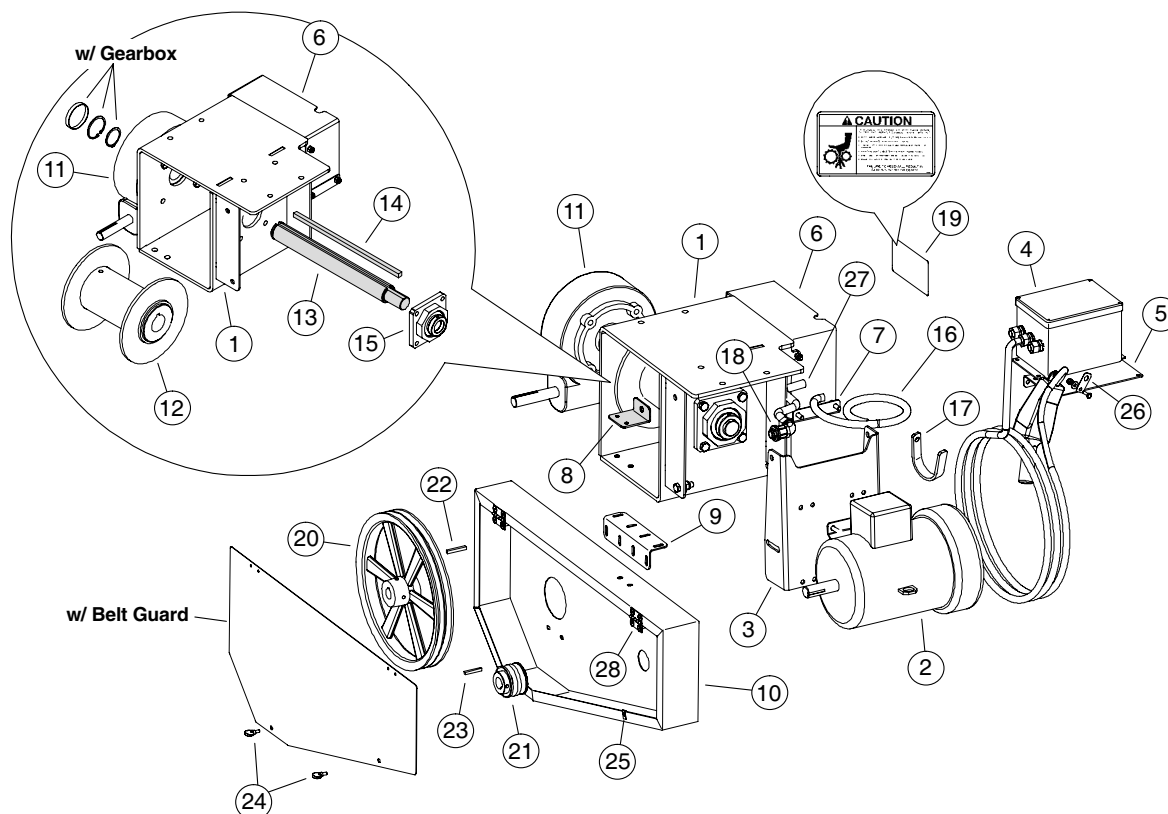

The complete winch assembly (Part No. 1032553) consists of all items listed below.

Ref. No.	Part No.	Description	Ref. No.	Part No.	Description
1	1032539	Frame, Winch Weldment	16	1035342	Cable, Power Supply, 12/4-600V 20 amps, .650" x 5' long
2	1034250	Motor, 5 HP, 3PH (184T frame)	17	1035351	Strap, Pendant Cable Holder
3	1032555	Plate, Motor Mount	18	1007339	Connector, 90° Electric
4	1042690	Control Box w/ Pendant	19	1006554	Decal, Caution, f/ Electric Winch
5	1043334	Plate, Control Box Mount	20	40157	Sheave, 15" O.D. x 1" bore 2B
6	1035366	Guard, Upper Half	21	40191	Sheave, 3" O.D. x 1 1/8" bore 2B
7	1035367	Guard, Lower Half	22	4045A1	Key, 1/4" sq. x 2" long
8	1032818	Bracket, Upper Belt Guard	23	8371C	Key, 1/4" sq. x 1 1/2" long
9	1032817	Bracket, Bottom Belt Guard	24	1013131	Wing Bolt, 1/4" x 1/2"
10	1038341	Belt Guard	25	1013133	Nut, 1/4" Tinnerman
11	1032536-1	Gearbox, 50:1 (LH assembly)	26	1043576	Hanger, f/ Pendant
12	1032551	Drum, Winch	27	1043587	Conduit, 1/2" flexible, 14" long
13	1032548	Shaft, f/ Winch	28	1013215	Hinge, 2" x 1 3/4"
14	1032840	Key, 1/2" sq. x 16" long			
15	1029745	Bearing, 1 1/2" (4 hole flange)			

# PARTS LIST

## UNDERCARRIAGE COMPONENTS

13" x 72' & 13" x 82' Top Drive Augers

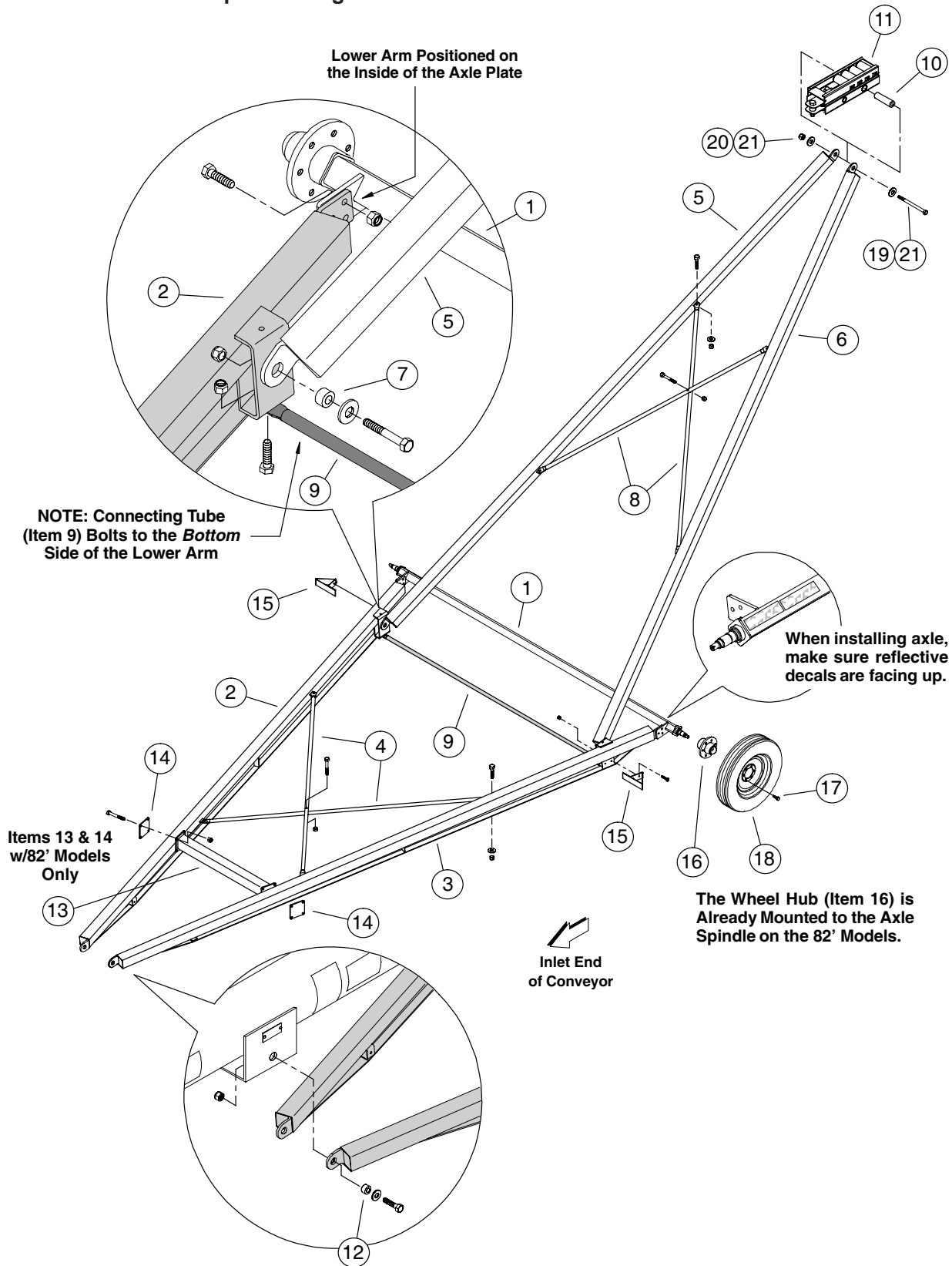

# PARTS LIST

## UNDERCARRIAGE COMPONENTS

### 13" x 72' & 13" x 82' Top Drive Augers

Ref. No.	Part No.	Description	Ref. No.	Part No.	Description
1	1021383	Axle, 72' Models	9	1019132	Connecting Tube f/ 72' (113.25" lg)
(1)	1034148	Axle, 82' Models	(9)	1034227	Connecting Tube f/ 82' (79.75" lg)
2	1018362	Radius Arm (left) f/ 72' (230.25" lg)	10	1020041	Bushing, Trolley ( 7 5/8" lg)
(2)	1033937	Radius Arm (left) f/ 82' (266" lg)	11	1021062	Trolley f/ 72' & 82' Models
3	1018361	Radius Arm (right) f/ 72' (230.25" lg)	12	1021198	Bushing (1 1/2" O.D. x 15/16" long)
(3)	1033938	Radius Arm (right) f/ 82' (266" lg)	13	1034253	Cross Stiffener (82' Models Only)
4	1020015	Radius Arm Crossbrace, f/ 72' (103.75" lg)	14	1029094	End Plate (82' Models Only)
(4)	1033952	Radius Arm Crossbrace, f/ 82' (99.75" lg)	15	1021204	Reflector Bracket
5	1018360	Lift Arm, f/ 72' (236" lg)	16	1025911	Hub Assembly, 6-Bolt
(5)	1033971	Lift Arm, f/ 82' (270" lg)	17	106241	Lug Bolt
6	1018360	Lift Arm, f/ 72' (236" lg)	18	1026197	Tire & Rim Assembly, 16"
(6)	1033971	Lift Arm, f/ 82' (270" lg)	19	1007941	Bolt, 1-8 x 11" G5 PLT
7	1021065	Bushing (1 1/2" O.D. x 11/16" long)	20	1007943	Nut, 1-8 Nylon Lock PLT
8	1019134	Lift Arm Crossbrace f/ 72' (95.5" lg)	21	D1160	Flat Washer, 1"
(8)	1034079	Lift Arm Crossbrace f/ 82' (95.25" lg)			

**Tire Spec's: 235/85R16, Part No. 1025913**

**Rim Spec's: 16" dia. x 6" wide 6-bolt, Part No. 1025912**

## COLLAPSIBLE AXLE 82' MODELS ONLY

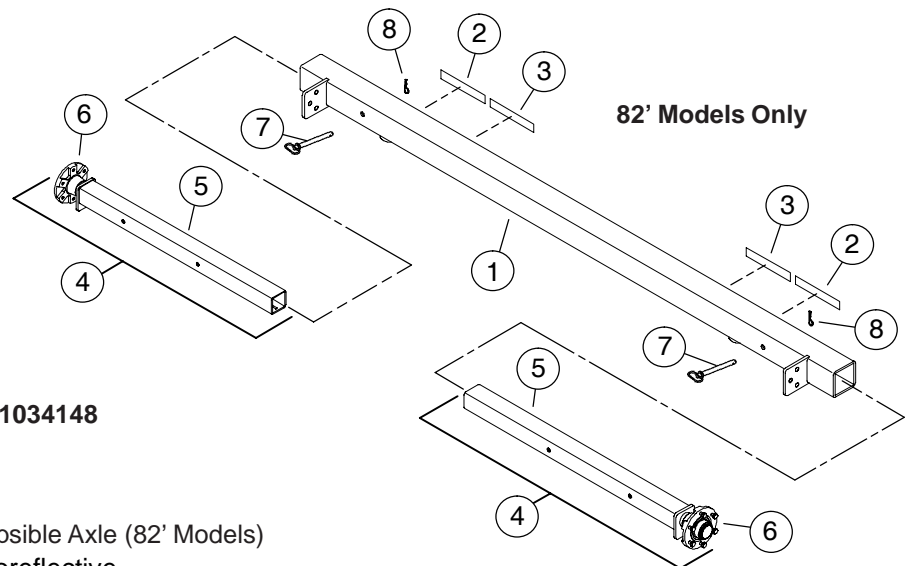

### Complete Axle, Order Part No. 1034148

Ref. No.	Part No.	Description
1	1033923	Axle Tube f/ Collapsible Axle (82' Models)
2	1021179	•Decal, Red Retroreflective
3	1021181	•Decal, Orange Transport
4	1033842	Collapsible Axle Assembly
5	1033649	•Collapsible Axle Weldment w/ Spindle
6	1025911	•Hub Assembly, 6-Bolt
7	1052538	Hitch Pin, 5/8" x 6" Lg.
8	D1166	•Hair Pin

•Indented Parts Names Indicate these Parts are Included in the Previous Assembly.

# PARTS LIST

Page P-16

## TROLLEY COMPONENTS

### 13" x 72' & 13" x 82' TOP DRIVE MODELS

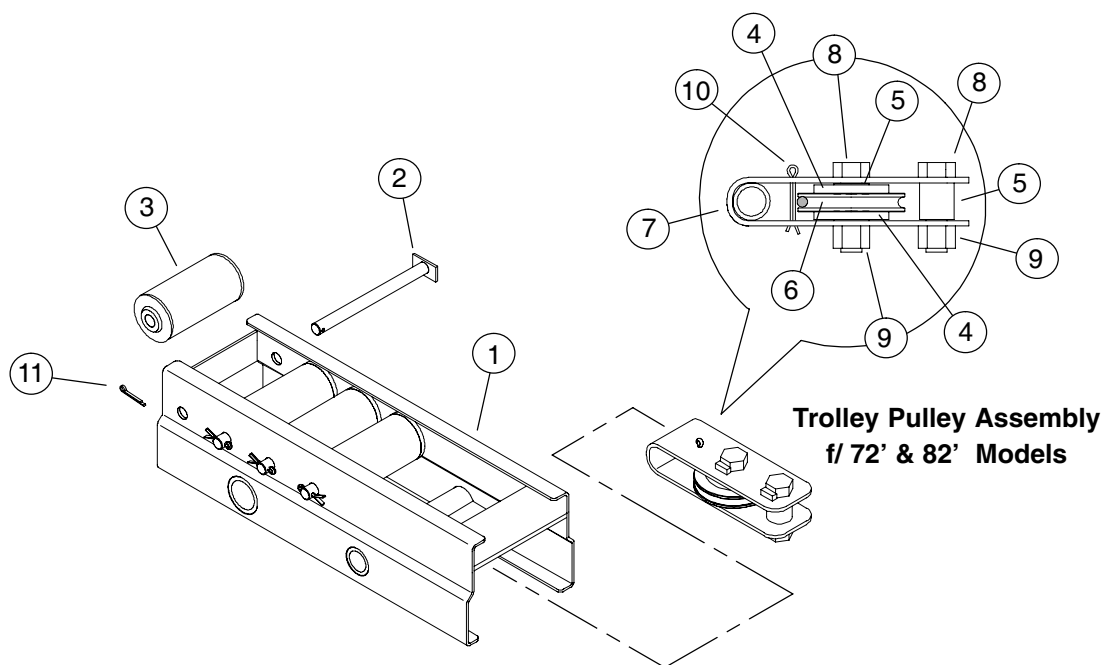

All parts listed are used for the 72' & 82' Models unless otherwise noted.

The trolley can be purchased as a complete assembly.

For 72' & 82' Models, order Part No. 1021062

Ref. No.	Part No.	Description	Ref. No.	Part No.	Description
1	1021077	Trolley Weldment f/ Winch Lift	7	1021154	Clevis, Pulley f/ 72' & 82' Models
2	1021057	Pin, Trolley	8	1021064	Bolt, 1-8 x 3 1/2" G8 PLT
3	1021060	Roller Assembly f/ Trolley	9	1007943	Nut, 1-8 Nylon Lock
4	1031583	Spacer, 3/8" thick	10	D1165	Cotter Pin, 1/4" x 3" long
5	1021146	Bushing, Pulley/Anchor	11	3337A1	Cotter Pin, 3/16" x 1 1/2" long
6	1021160	Pulley, f/ 1/2" Cable			

# PARTS LIST

## HEAD GEARBOX COMPONENTS

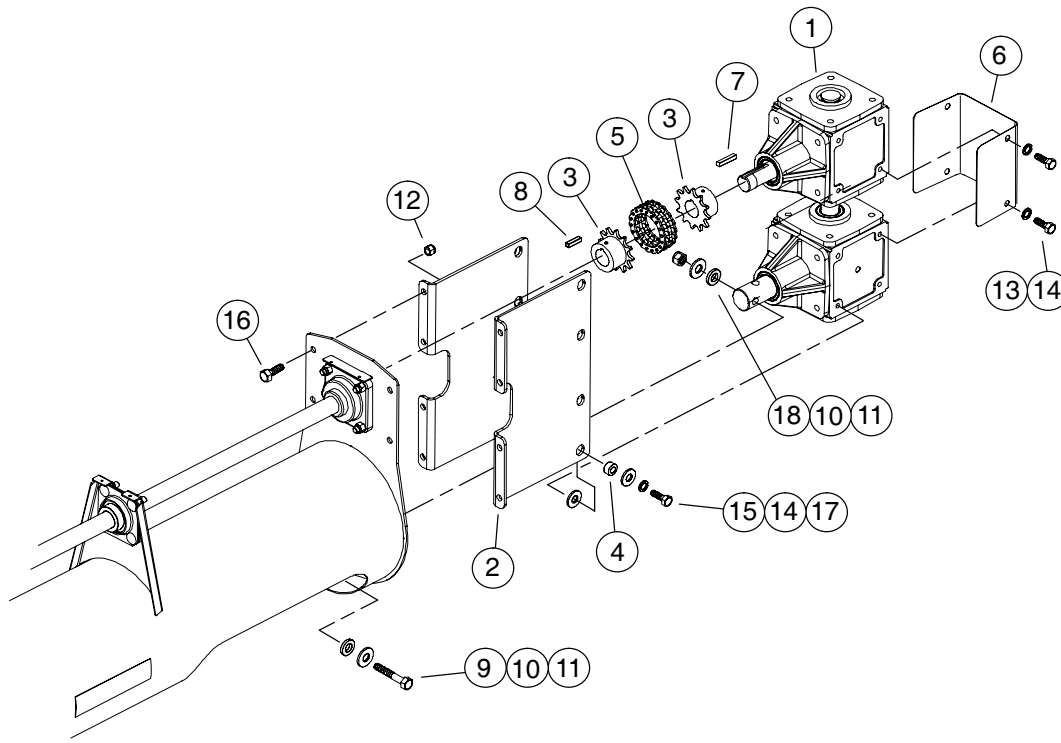

Ref. No.	Part No.	Description	Ref. No.	Part No.	Description
1	1034053-1	Gearbox, 1:1 reduction	9	1010485	Bolt, 5/8-11 x 4" G8 BLK
2	1054158	Mount Plate f/ Gear Drive	10	33026	Washer, 5/8" Flat PLT
3	1054145	Coupler Half, 50 Chain 18T w/ 1-1/2" bore	11	1022476	Rubber Washer, 5/8"
4	1054154	Spacer Bushing	12	33138	Nut, 1/2-13 Nylon Lock PLT
5	1054155	Coupler Chain, RC50 f/ 18T Sprocket	13	1002226	Bolt, 1/2 -13 x 3/4" G5 PLT
6	1037546	Cover, Double Gearbox Shaft	14	D1143	Lock Washer, 1/2" PLT
7	1038D	Key, 3/8" sq. x 2" long	15	33294	Bolt, 1/2 -13 x 1" G5 PLT
8	4049A1	Key, 3/8" sq. x 1-1/2" long CR	16	33082	Bolt, 1/2-13 x 1 1/2" G5 PLT
			17	33025	Washer. 1/2" Flat PLT
			18	1005111	Locknut, 5/8-11 side depress

# PARTS LIST

## COLLAPSIBLE HOPPER COMPONENTS 13" X 72' and 13" X 82' Top Drive Models

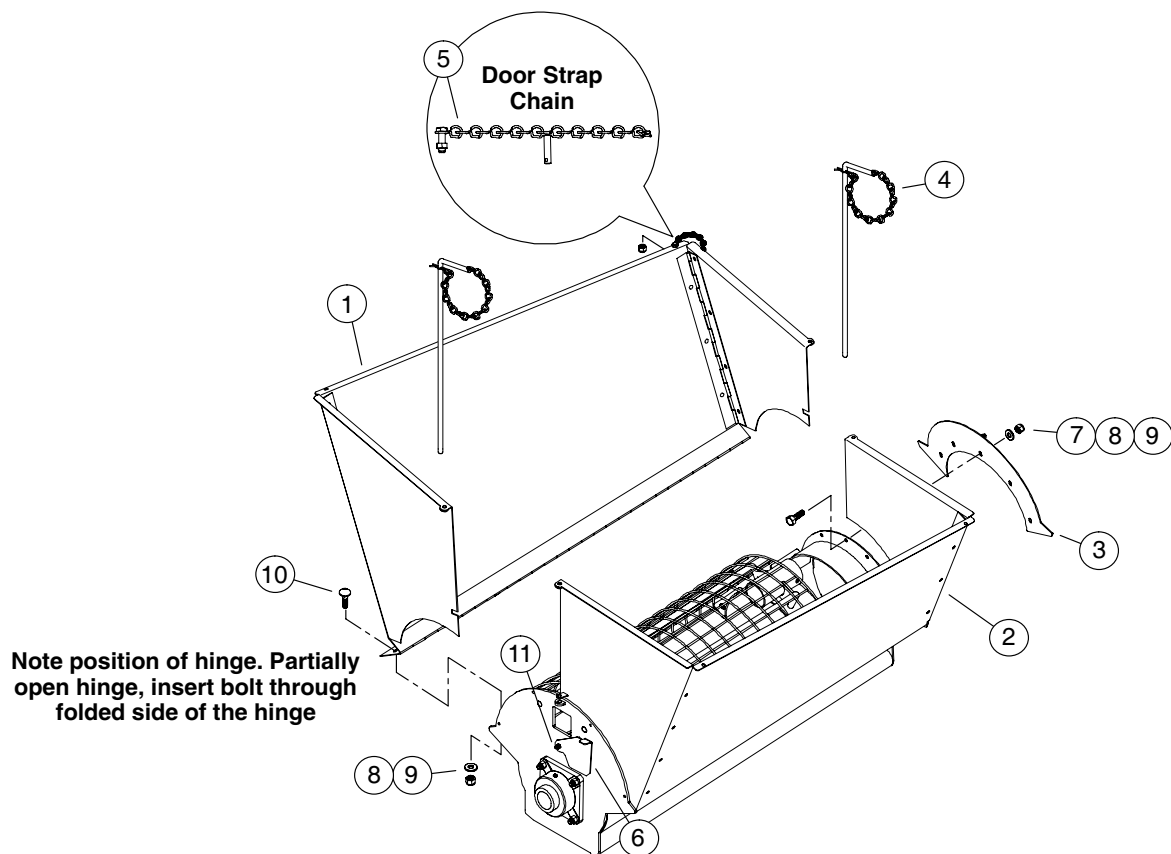

**Complete Hopper Kit can be Obtained  
by Ordering: Part No. 1038044  
(complete hopper kit includes all items shown)**

Ref. No.	Part No.	Description	Ref. No.	Part No.	Description
1	1038021	Left Side, Collapsible Hopper	7	4705-1	Bolt, 5/16-18 x 3/4" G5 PLT
2	1038022	Right Side, Collapsible Hopper	8	33023	Flat Washer, 5/16" PLT
3	1038019	Rear Filler Plate	9	33135	Nut, 5/16-18 Nylon Lock PLT
4	1038193	Pin, Collapsible Hopper	10	33019	Bolt, Elevator, 5/16-18 x 1 1/4" G5 PLT
5	1038173	Chain Strap w/ Nylon Locknut	11	4003	Nut, 1/4-20 Nylon Lock PLT
6	1043226	Hitch Cover Plate			

## FLEX HOPPER COMPONENTS

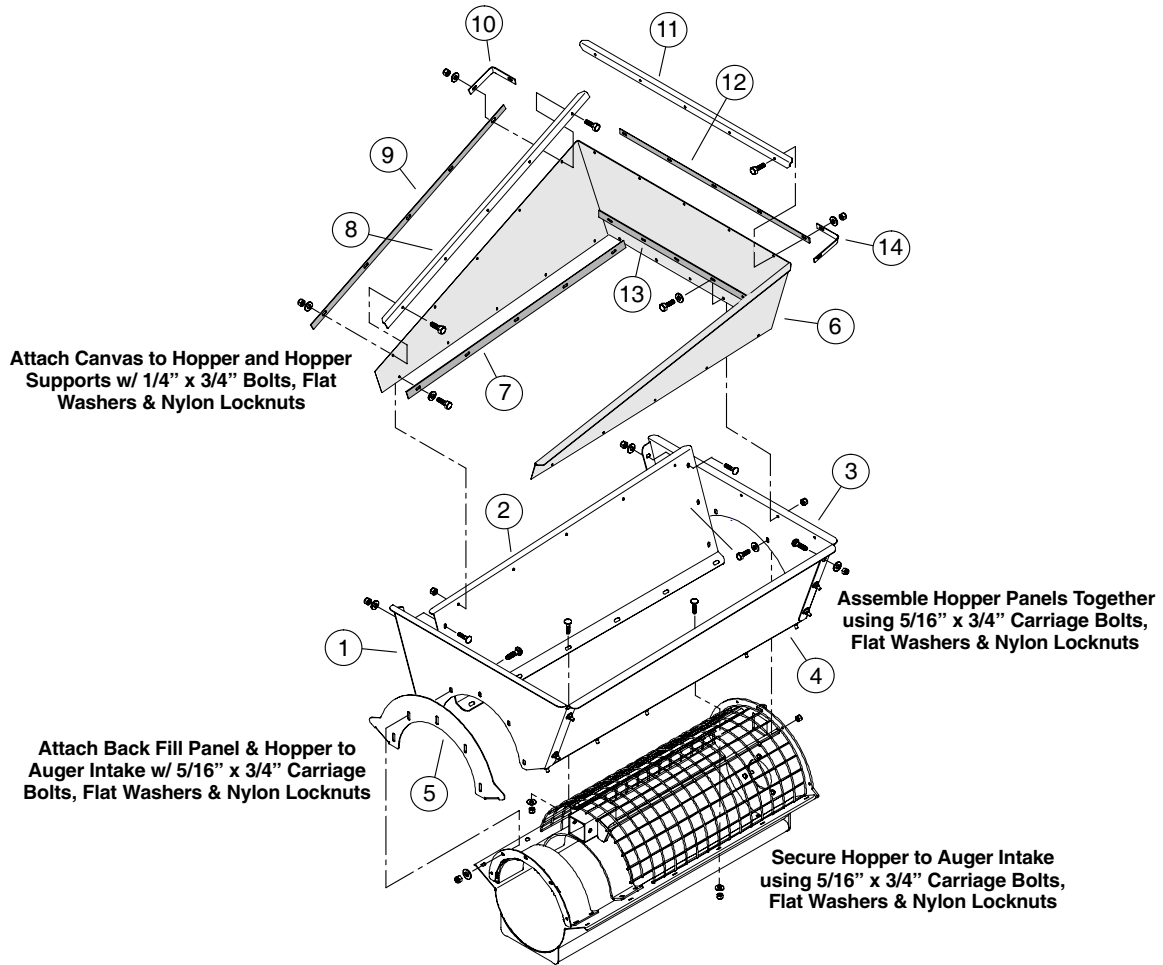

**Complete Hopper Kit can be Obtained  
by Ordering: Part No. 1051355  
(complete hopper kit includes all items shown)**

Ref. No.	Part No.	Description	Ref. No.	Part No.	Description
1	1051076	Rear Panel f/ Flex Hopper	8	1039324	Support Angle (sides)
2	1051096	Left Side Panel f/ Flex Hopper	9	1039327	Clamp Strip (top sides)
3	1051094	Front Panel f/ Flex Hopper	10	1039335	Corner Clamp (right side)
4	1051095	Right Side Panel f/ Flex Hopper	11	1039325	Support Angle (rear)
5	1051077	Panel, Back Fill	12	1039329	Clamp Strip (top rear)
6	1039309	Rubber Boot	13	1039328	Clamp Strip (bottom rear)
7	1039326	Clamp Strip (bottom sides)	14	1039334	Corner Clamp (left side)

# PARTS LIST

Page P-20

## MAIN AUGER COMPONENTS W/ INTERNAL BEARINGS 72' PTO DRIVE MODELS

### 72' Model w/ Internal Bearings

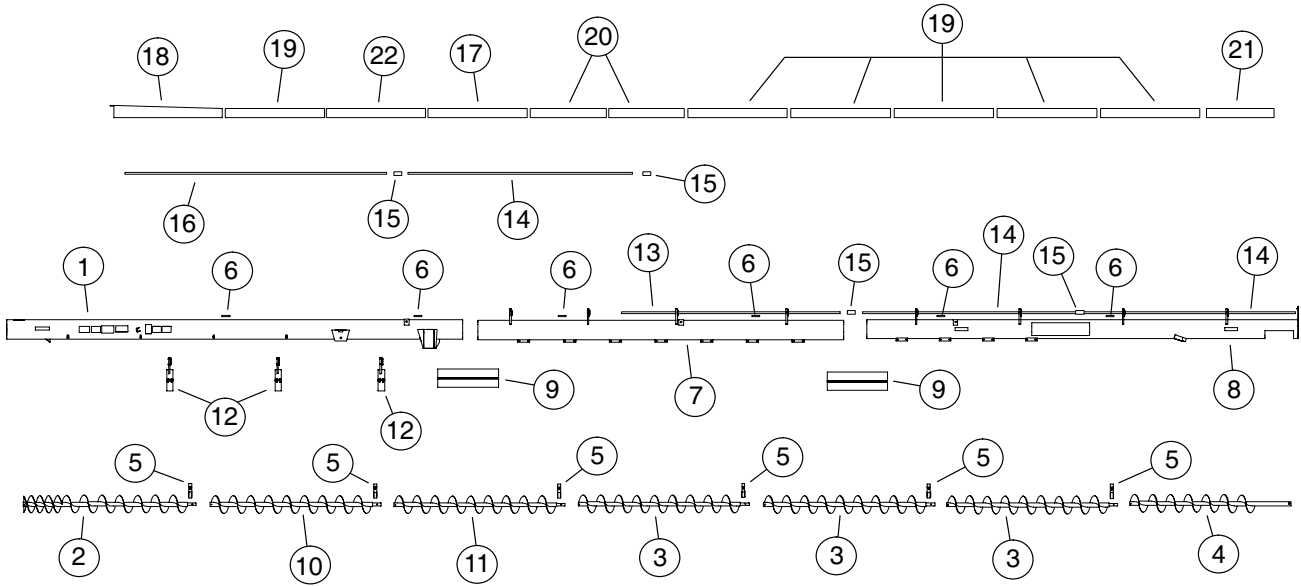

Ref. No.	Part No.	Description	Ref. No.	Part No.	Description
1	1040042-130	Lower Tube Section f/ 72' w/ Internal Bearings	10	1040201	Mid Flight, 1/4" (139 1/2" lg)
2	1039859	Lower Flight, 1/4" (141 1/4" lg)	11	1040203	Mid Flight, 1/4" (103" lg)
3	1035240	Mid Flight, 1/4" (117 1/4" lg)	12	1037420	Band-On Bearing Mount
4	1035242	Upper Flight, 1/4" (49 5/16" lg)	13	1040035	Drive Shaft, 1 1/2" dia. x 141 1/4" lg
5	1035183	Internal Bearing Hanger	14	1040030	Drive Shaft, 1 1/2" dia. x 150" lg
6	1012367	Mount Plate f/ Internal Bearing	15	1036076	Coupler, 1 1/2" x 1 1/2"
7	1040043-130	Mid Tube Section f/ 72' Models f/ Internal Bearing	16	1034818	Drive Shaft, 1 1/2" dia. x 200 1/8" lg
8	1040044-230	Head Tube Section f/ 72' Models f/ Internal Bearing (Hutchinson)	17	1040364	Drive Shaft Cover, 81 9/32" long
(8)	1040044-330	Head Tube Section f/ 72' Models f/ Internal Bearing (Mayrath)	18	1038093	Drive Shaft Cover, 65 29/32" lg
9	1033444	Connecting Band, 13"	19	1034813	Drive Shaft Cover, 73" lg
			20	1036244	Drive Shaft Cover, 55 1/2" lg
			21	1036246	Drive Shaft Cover, 50 1/4" lg
			22	1040363	Drive Shaft Cover, 65 1/2" long

# PARTS LIST

**MAIN AUGER COMPONENTS**  
**W/ INTERNAL BEARINGS**  
**72' ELECTRIC DRIVE MODELS**

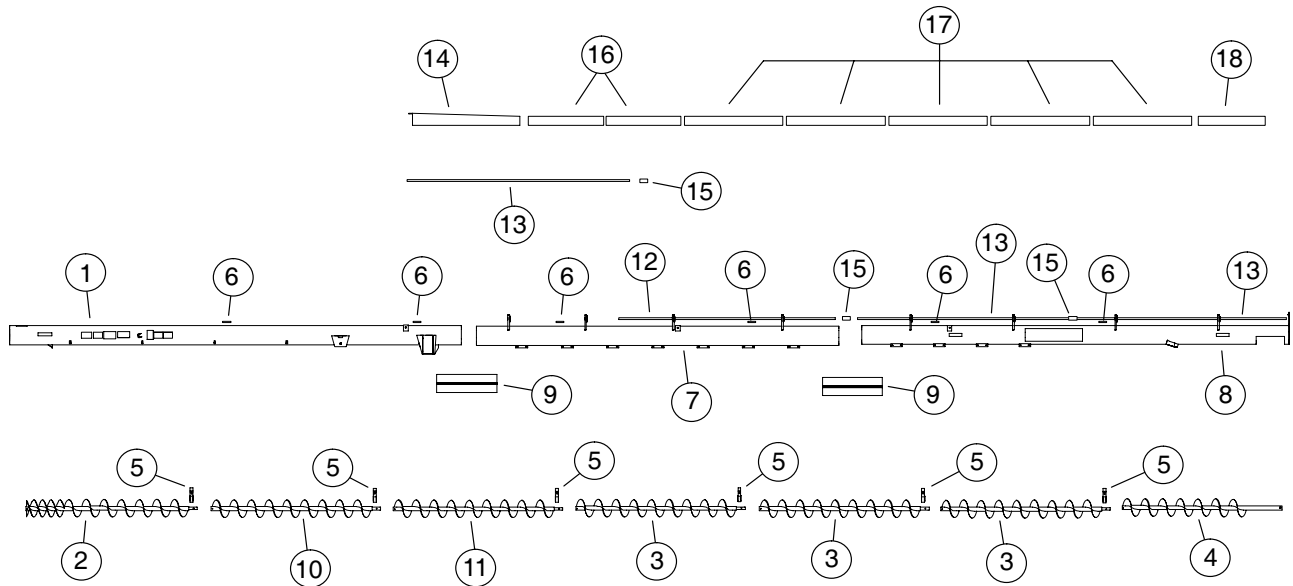

Ref. No.	Part No.	Description	Ref. No.	Part No.	Description
1	1040042-130	Lower Tube Section f/ 72' w/ Internal Bearings	9	1033444	Connecting Band, 13"
2	1039859	Lower Flight, 1/4" (141 1/4" lg)	10	1040201	Mid Flight, 1/4" (139 1/2" lg)
3	1035240	Mid Flight, 1/4" (117 1/4" lg)	11	1040203	Mid Flight, 1/4" (103" lg)
4	1035242	Upper Flight, 1/4" (49 5/16" lg)	12	1040035	Drive Shaft, 1 1/2" dia. x 141 1/4" lg
5	1035183	Internal Bearing Hanger	13	1040030	Drive Shaft, 1 1/2" dia. x 150" lg
6	1012367	Mount Plate f/ Internal Bearing	14	1037253	Drive Shaft Cover, 81 1/2" lg
7	1040043-130	Mid Tube Section f/ 72' Models f/ Internal Bearing	15	1036076	Coupler, 1 1/2" x 1 1/2"
8	1040044-230	Head Tube Section f/ 72' Models f/ Internal Bearing (Hutchinson)	16	1036244	Drive Shaft Cover, 55 1/2" lg
(8)	1040044-330	Head Tube Section f/ 72' Models f/ Internal Bearing (Mayrath)	17	1034813	Drive Shaft Cover, 73" lg
			18	1036246	Drive Shaft Cover, 50 1/4" lg

# PARTS LIST

## MAIN AUGER COMPONENTS W/ INTERNAL BEARINGS 82' PTO DRIVE MODELS

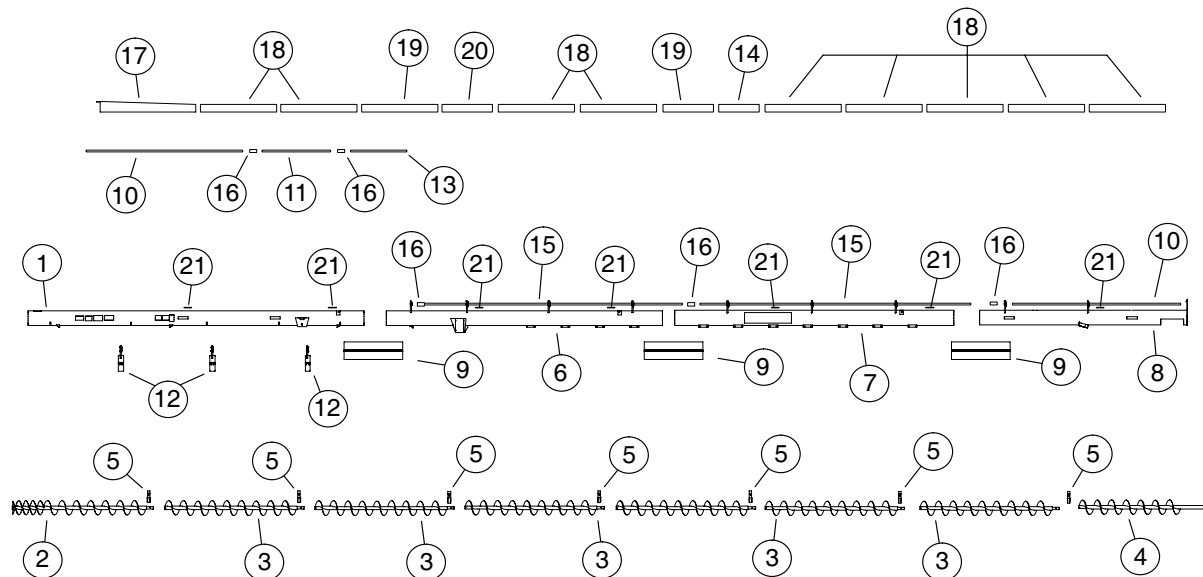

Ref. No.	Part No.	Description
1	1036301-130	Lower Tube Section f/ 82' w/ Internal Bearings
2	1035244P	Lower Flight, 1/4" (136 13/16" lg)
3	1035240P	Mid Flight, 1/4" (120" lg)
4	1054282P	Upper Flight, 1/4" (135" lg)
5	1035183	Internal Bearing Hanger
6	1036302-130	Lower Mid Tube Section f/ 82' w/ Internal Bearings
7	1036303-130	Upper Mid Tube Section f/ 82' w/ Internal Bearing
8	1054279-130	Head Tube Section f/ 82' Models w/ Internal Bearings
9	1033444	Connecting Band, 13"

Ref. No.	Part No.	Description
10	1054285	Drive Shaft, 1 1/2" dia. x 154 3/4" lg
11	1040440	Drive Shaft, 1 1/2" dia. x 82 13/16" lg
12	1037420	Band-On Bearing Mount
13	1054540	Drive Shaft, 1 1/2" dia. x 51" lg
14	1036766	Drive Shaft Cover, 26 15/32" lg
15	1034198	Drive Shaft, 1 1/2" dia. x 240" lg
16	1036076	Coupler, 1 1/2" I.D. x 1 1/2" I.D.
17	1037957	Drive Shaft Cover, 87 3/8" lg
18	1034813	Drive Shaft Cover, 73" lg
19	1038504	Drive Shaft Cover, 61" lg
20	1035858	Drive Shaft Cover, 49" lg
21	1012367	Mount Plate f/ Internal Bearing

# PARTS LIST

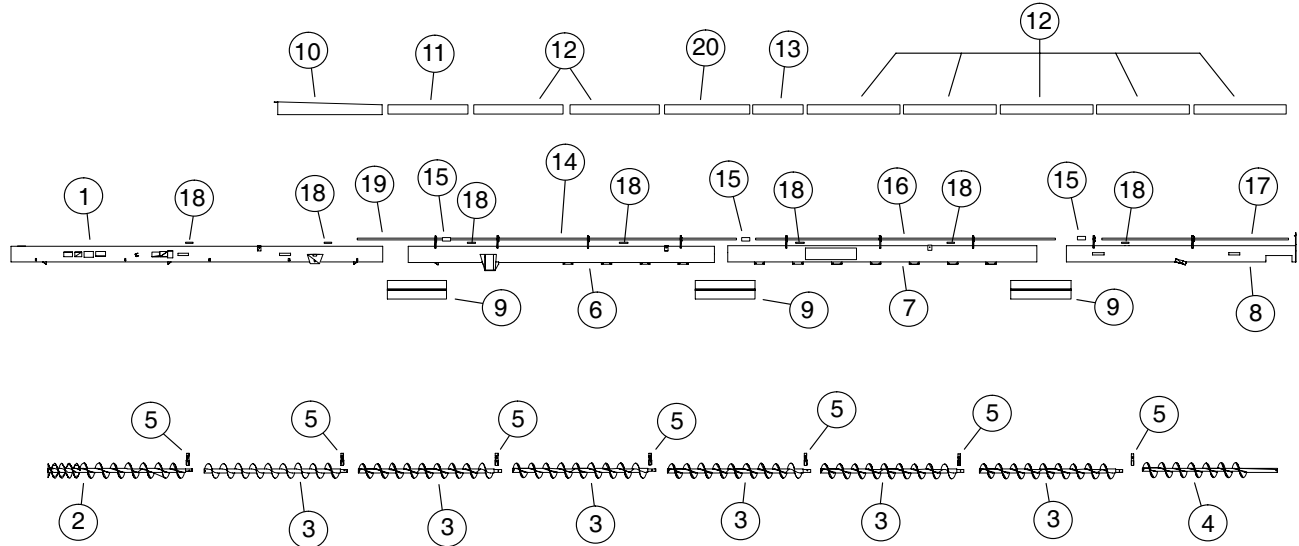

**MAIN AUGER COMPONENTS**  
**W/ INTERNAL BEARINGS**  
**82' ELECTRIC DRIVE MODELS**



Ref. No.	Part No.	Description	Ref. No.	Part No.	Description
1	1036301-130	Lower Tube Section f/ 82' w/ Internal Bearings	9	1033444	Connecting Band, 13"
2	1035244P	Lower Flight, 1/4" (136 13/16" lg)	10	1037969	Drive Shaft Cover, 58 9/32" lg
3	1035240P	Mid Flight, 1/4" (120" lg)	11	1035858	Drive Shaft Cover, 49" lg
4	1035242P	Upper Flight, 1/4" (130" lg)	12	1034813	Drive Shaft Cover, 73" lg
5	1035183	Internal Bearing Hanger	13	1036766	Drive Shaft Cover, 27" lg
6	1036302-130	Lower Mid Tube Section f/ 82' w/ Internal Bearings	14	1034198	Drive Shaft, 1 1/2" dia. x 240" lg
7	1036303-130	Upper Mid Tube Section f/ 82' w/ Internal Bearing	15	1036076	Coupler, 1 1/2" I.D. x 1 1/2" I.D.
8	1054279-130	Head Tube Section f/ 82' Models w/ Internal Bearings	16	1034198	Drive Shaft, 1 1/2" dia. x 240" lg
			17	1054285	Drive Shaft, 1 1/2" dia. x 154 3/4" lg
			18	1012367	Mount Plate f/ Internal Bearing
			19	1054540	Drive Shaft, 1 1/2" dia. x 51" lg
			20	1038504	Drive Shaft Cover, 61" lg

# PARTS LIST

## TORQUE CHART

<b>General Torque Specification Table</b> <b>Use the Following Torques When Special Torques Are Not Given</b> Note: These values apply to fasteners as received from supplier, dry, or when lubricated with normal engine oil. They do not apply if special graphited or moly-disulphide greases or other extreme pressure lubricants are used. This applies to both UNF and UNC threads.													
SAE Grade No.		SAE 2				SAE 5				SAE 8*			
Bolt head identification marks as per grade Note: Manufacturing marks will vary													
		Torque		Torque		Torque		Torque		Torque		Torque	
Bolt Size		Foot Pounds		Newton-Meters		Foot Pounds		Newton-Meters		Foot Pounds		Newton-Meters	
Inches	Millimeters	Min.	Max.	Min.	Max.	Min.	Max.	Min.	Max.	Min.	Max.	Min.	Max.
1/4	6.35	5	6	6.8	8.13	9	11	12.2	14.9	12	15	16.3	20.3
5/16	7.94	10	12	13.6	16.3	17	20.5	23.1	27.8	24	29	32.5	39.3
3/8	9.53	20	23	27.1	31.2	35	42	47.5	57.0	45	54	61.0	73.2
7/16	11.11	30	35	40.7	47.4	54	64	73.2	86.8	70	84	94.9	113.9
1/2	12.70	45	52	61.0	70.5	80	96	108.5	130.2	110	132	149.2	179.0
9/16	14.29	65	75	88.1	101.6	110	132	149.2	179.0	160	192	217.0	260.4
5/8	15.88	95	105	128.7	142.3	150	180	203.4	244.1	220	264	298.3	358.0
3/4	19.05	150	185	203.3	250.7	270	324	366.1	439.3	380	456	515.3	618.3
7/8	22.23	160	200	216.8	271.0	400	480	542.4	650.9	600	720	813.6	976.3
1	25.40	250	300	338.8	406.5	580	696	786.5	943.8	900	1080	1220.4	1464.5
1 1/8	25.58	----	----	----	----	800	880	1084.8	1193.3	1280	1440	1735.7	1952.6
1 1/4	31.75	----	----	----	----	1120	1240	1518.7	1681.4	1820	2000	2467.9	2712.0
1 3/8	34.93	----	----	----	----	1460	1680	1979.8	2278.1	2380	2720	3227.3	3688.3
1 1/2	38.10	----	----	----	----	1940	2200	2630.6	2983.2	3160	3560	4285.0	4827.4

\*Thick nuts must be used with Grade 8 bolts

# WARRANTY

## AG GROWTH INTERNATIONAL INC. – FORM OF LIMITED WARRANTY

Ag Growth International Inc. (“AGI”) warrants that the goods and/or services being supplied (the “Goods”) will be free from defects in materials and workmanship under normal conditions, use, service, and maintenance, for a period of twelve (12) months from the date of first operation of the Goods, but in no event more than eighteen (18) months from the date of delivery of the Goods to the end-user (the “Warranty Term”). If the Goods are being used for rental purposes, the Warranty Term for the subject Goods shall be limited to 90 days.

Subject to AGI’s sole discretion, if the Goods, or a component thereof, are found to have a default in materials and/or workmanship within the Warranty Term, AGI will, at its own option and expense, repair or replace the subject Goods or refund the purchase price for the applicable Goods. Any warranty related expenses incurred on behalf of or by the end-user without the prior written consent of AGI shall be the sole responsibility of the end-user. Expenses relating to travel, customs or import duties and tariffs, equipment rental, and any costs associated with accessing the Goods are the sole responsibility of the customer. Warranty shall be void in the event the Goods are returned or disposed of without the written consent of AGI.

The customer shall not assert a claim that the Goods are defective unless the customer gives written notice to AGI of such defect within forty-eight (48) hours of discovering such defect. In the event of a warranty claim, the customer must complete any and all information required by AGI in order to properly assess or investigate the claim. AGI shall be given a reasonable opportunity to inspect and test the Goods in question. Failure by the customer to notify AGI of such claim within 48 hours shall operate as a waiver of any and all such claims by the customer.

**THIS IS THE SOLE AND EXCLUSIVE WARRANTY GIVEN BY AGI WITH RESPECT TO THE GOODS AND IS IN LIEU OF AND EXCLUDES ALL OTHER WARRANTIES, EXPRESS OR IMPLIED, ARISING BY OPERATION OF LAW OR OTHERWISE, INCLUDING WITHOUT LIMITATION, MERCHANTABILITY OR FITNESS FOR A PARTICULAR PURPOSE WHETHER OR NOT THE PURPOSE OR USE HAS BEEN DISCLOSED TO SELLER IN SPECIFICATIONS, DRAWINGS, OR OTHERWISE, AND WHETHER OR NOT AGI’S GOODS ARE SPECIFICALLY DESIGNED AND/OR MANUFACTURED BY AGI FOR BUYER’S USE OR PURPOSE.**

This limited warranty extends solely to Goods manufactured by AGI and does not cover any third-party parts, components, or materials. To the extent permitted by the manufacturer, AGI will pass on applicable warranties on third-party parts, components or materials to the end-user. This warranty does not extend to any losses or damages due to misuse, use of a kind and/or to a degree not reasonably expected to be made of the Goods, any use of the Goods which is not an intended use as specified in AGI’s published product literature or otherwise specified by AGI in writing, accident, acts of God, abuse, neglect, normal wear and tear (including corrosion and cosmetic issues), any equipment attached to or used in conjunction with the Goods, any field modifications or substitutions to original Goods, component damage incurred during shipping and handling, unauthorized modification or alteration, used beyond rated capacity, or improper installation, maintenance or application.

**THE SOLE AND EXCLUSIVE REMEDY FOR ANY CLAIM HEREUNDER SHALL BE LIMITED TO REPAIR, REPLACEMENT, OR REFUND OF THE PURCHASE PRICE. AGI SHALL NOT BE LIABLE FOR DAMAGES CAUSED BY DELAY IN PERFORMANCE AND IN NO EVENT, REGARDLESS OF THE FORM OF THE CLAIM OR CAUSE OF ACTION (WHETHER BASED IN CONTRACT, INFRINGEMENT, NEGLIGENCE, STRICT LIABILITY, OTHER TORT OR OTHERWISE), SHALL AGI’S LIABILITY TO BUYER AND/OR ITS CUSTOMERS EXCEED THE PURCHASE PRICE OF THE GOODS. BUYER AGREED THAT IN NO EVENT SHALL AGI’S**

**LIABILITY TO BUYER AND/OR ITS CUSTOMERS EXTEND TO INCLUDE INCIDENTAL, CONSEQUENTIAL, OR PUNITIVE DAMAGES. THE TERM "CONSEQUENTIAL DAMAGES" SHALL INCLUDE, BUT NOT BE LIMITED TO, LOSS OF ANTICIPATED PROFITS, LOSS OF USE, LOSS OF REVENUE, FAILURE TO MEET GOVERNMENT AND/OR ADMINISTRATIVE REQUIREMENTS, CLEAN UP COSTS, COST OF CAPITAL AND DAMAGE OR LOSS TO OTHER GOODS, PROPERTY OR EQUIPMENT.**

To the fullest extent permitted by law, Buyer, on behalf of itself, its suppliers, their agents, employees or any entity or person for which Buyer is or may be responsible ("Indemnitors") shall fully indemnify, save and hold AGI, its agents, employees, officers, directors, partners and related entities harmless from and against all liability, damage, loss, claims, demands, actions and expenses of any nature whatsoever, including, but not limited to reasonable attorney's fees which arise out of or are connected with: (a) any negligent act, error or omission by any Indemnitor in the performance of this agreement; (b) the failure of the Indemnitor to comply with the laws, statutes, ordinances or regulations of any governmental or quasi-governmental authority; or (c) the material breach of any term or condition of this agreement by any of the Indemnitors. Without limiting the generality of the foregoing, the indemnity hereinabove set forth shall include all liability, damage, loss, claims, demands, and actions on account of personal injury, death or property loss to any third party, any Indemnitee, any of Indemnitee's employees, agents, licensees or invitees. The indemnity set forth herein shall survive any termination of this agreement.

**THIS WARRANTY IS NON-TRANSFERABLE AND APPLIES ONLY TO THE ORIGINAL END-USER AND SHALL BE CONSIDERED VOID IF NOT REGISTERED WITHIN 30 DAYS OF RECEIPT OF THE GOODS BY THE ORIGINAL END USER.**



# **AGI HUTCHINSON MAYRATH**

MANUFACTURED BY  
**HUTCHINSON | MAYRATH**

P.O. Box 629, 514 W. Crawford Street    **TF** 800.523.6993  
Clay Center, Kansas                        **P** 785.632.2161  
USA 67432                                        **F** 785.632.5964

**[hutchinson-mayrath.com](http://hutchinson-mayrath.com)**