

1214 SERIES INDUSTRIAL KLEAN SWEEP AUGERS with SWEEP TRACTOR

OWNER'S & OPERATOR'S MANUAL

Effective September, 24, 2024

Publication No. 1031387

3:1 Chain Drive Reducer Gearbox

36' to 78' Bin Diameters

BK1436SD	BK1455SD
BK1437SD	BK1459SD
BK1440SD	BK1460SD
BK1442SD	BK1462SD
BK1443SD	BK1468SD
BK1448SD	BK1472SD
BK1449SD	BK1475SD
BK1454SD	BK1478SD

4:1 Gear Drive Reducer Gearbox

80' to 120' Bin Diameters

BK1480SD	BK14105SD
BK1488SD	BK14113SD
BK1490SD	BK14120SD
BK1492SD	

IMPORTANT!

The gearboxes are shipped **Without Oil**.
Oil must be added before operation.
Refer to the Lubrication Section in this manual.

AGI **HUTCHINSON MAYRATH**

Hutchinson | Mayrath • 514 W. Crawford • Clay Center, KS. USA 67432

P 785.632.2161 • F 785.632.5964 • TF 800.523.6993

hutchinson-mayrath.com

aggrowth.com | **AGI** 

GENERAL SAFETY STATEMENT

This manual was written with the safety of the operator and others who work with the equipment as our prime concern. The instructions presented will help the reader learn **SAFE** day to day work practices. We want you as our partner in safety.

It is your responsibility as an owner, operator or supervisor to know what specific safety requirements and precautions exist and to make these known to all other personnel working with the equipment or in the area, so that they too may safely perform their duties and avoid any potentially hazardous situations.

Please remember safety equipment provides important protection for persons around a grain handling system that is in operation. Be sure **ALL** safety shields and protection devices are installed and properly maintained. **If any shields or guards are damaged or missing, contact your dealer to obtain the correct replacement items.**

Avoid any alterations of the equipment. Such alterations may create a dangerous situation where serious injury or death may occur.

SAFETY ALERT SYMBOL

The safety symbol shown is used throughout this manual to alert you to information about unsafe actions or situations, and will be followed by the word **DANGER, WARNING, or CAUTION.**

DANGER - Indicates immediate hazards that may result in severe injury or death. **WARNING** - Indicates unsafe actions or situations that may cause severe injury, death and/or major equipment or property damage. **CAUTION** - Indicates unsafe actions or situations that may cause injury, and/or minor property damage.

Watch this symbol - it points out important safety precautions. It means - **ATTENTION! Become alert! Your safety and the safety of others is involved!** Read the message that follows the symbol when a warning is given, be alert to the possibility of personal injury or death.



SAFETY DECALS

Check all safety decals to ensure they are present and in good condition. If a decal cannot easily be read for any reason, replace it immediately. Decals are offered free of charge and can be ordered through your Hutchinson/ Mayrath dealer or directly from the factory.

Danger Decal, No. 1002303 is supplied with the bin unloading equipment. This safety decal should be applied to the side of the bin opening so it can be viewed by people entering into the bin or storage structure.

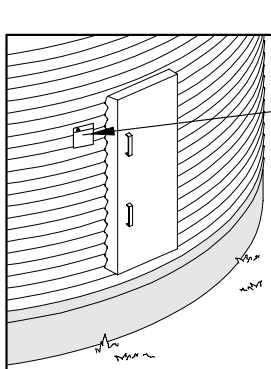

**1002303-1
Rotating Flight Hazard
Apply to Outside of Bin
or Storage Structure**

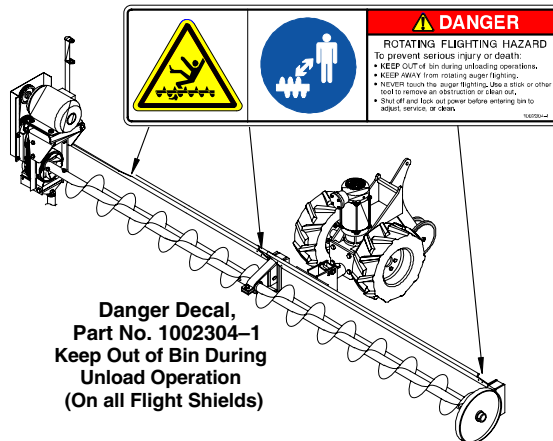

**Danger Decal,
Part No. 1002304-1
Keep Out of Bin During
Unload Operation
(On all Flight Shields)**

TABLE OF CONTENTS

SAFETY	1
General Safety Statement	1
Safety Alert Symbol & Safety Decals	1
TABLE OF CONTENTS	2
GENERAL INFORMATION	3 - 8
Operator Qualifications	3
Sign-Off Sheet	3
Machine Inspection	4
Designated Work Area	4
Powerhead Information	4
Electric Motor Drives	5
Horsepower Requirements & Flight Speed Chart	5
Start-Up Information	6
Bin Unloading Information	6
Intermediate Well Information	7
Installation Information	7-8
OPERATING PROCEDURES	9 - 10
Sweep Auger Start-up	9
Final Clean-Up	10
Shutdown	10
Normal Shutdown	10
Emergency Shutdown	10
Lockout	10
Trouble Shooting	10
Low Capacity	10
Sweep Flight Not Moving	10
Grain Plugging Unload Auger	10
LUBRICATION & MAINTENANCE	11 - 12
Lubrication	11
4:1 Reducer Gearbox	11
3:1 Reducer Gearbox	11
Sweep Maintenance	12
Bearing Stand Bronze Bearing	12
Sweep Tractor	12
Drive Belt Adjustment	12
ASSEMBLY INSTRUCTIONS	13 - 32
3:1 Chain Reducer Drive Assembly (for 36' to 78' Bin Dia's.)	13 - 14
4:1 Gear Reducer Drive Assembly (for 80' to 120' Bin Dia's.)	15 - 16
Electric Motor Connection	17
Flight and Sweep Shields	18 - 20
Flight, Shield, Truss and Truss Cable (for units with 4 or more flight sections)	21 - 22
Sweep Tractor and Weights	23 - 26
Sweep Flight Section Assemblies	26 - 32
PARTS LIST TABLE of CONTENTS	P-1
WARRANTY	W-1

OPERATOR'S QUALIFICATIONS



WARNING

Anyone who will operate or work around this machine shall first read this manual! This manual must be delivered with the equipment to its owner. Failure to read this manual and its safety instructions is a misuse of the equipment.

Operation of this auger shall be limited to competent and experienced persons. In addition, anyone who will operate or work around an auger must use good common sense. In order to be qualified, the operator must also know and meet all other requirements, such as:

1. Some regulations specify that no one under the age of 16 may operate power machinery. This includes this auger. It is your responsibility to know what these regulations are in your area or situation.
2. Current OSHA regulations state in part: "At the time of initial assignment and at least annually thereafter, the employer shall instruct every employee in safe operation and servicing of all equipment with which the employee is, or will be involved."*

3. Unqualified persons are to stay out of the work area. See Page 4 for Designated Work Area.
4. A person who has not read and understood all operating and safety instructions is not qualified to operate the machine.

* Federal Occupational Safety & Health Standards for Agriculture Subpart D, Section 1928.57 (a) (6).

SIGN-OFF SHEET

As a requirement of OSHA, it is necessary for the employer to train the employee in the safe operation and safety procedures with this auger. We include this sign off sheet for your convenience and personal record keeping.

<u>Training Sign-Off Sheet</u>		
Date	Employer Signature	Employee Signature

GENERAL INFORMATION

MACHINE INSPECTION

After delivery of your new auger and/or completion of assembly and before each use, inspection of the machine is mandatory. Use the assembly instructions in this manual as a reference to determine that the auger is assembled properly. This inspection should include, but not be limited to:

1. Check to see that all guards listed in the assembly instructions are in place, secured and functional.
2. Check all safety signs (decals) and replace any that are worn, missing or illegible. Safety signs may be obtained free of charge from your dealer or ordered from the factory.
3. Check **all** fasteners; nuts, bolts, set screws etc. for tightness.
4. Check oil level in gearboxes (See the Lubrication and Maintenance Section).
5. Check all electrical connections and wiring.
6. Check drive belts for proper tension. Also check belts for fraying, cracking or any other damage. Replace as necessary.

POWER HEAD INFORMATION



WARNING! DO NOT enter the grain bin unless all power driven equipment has been shut down and locked out.

Keep all safety shields and devices in place. Keep hands, feet, and clothing away from moving parts.



The operator should have a full view of the auger work area and check that all personnel are free from designated work areas before adding power.

- Obtain any needed replacement parts from your dealer and install **before** using the machine.
- It is important to become familiar with the routine operating procedures before attempting start-up.
- Inspect the drive before adding power and know how to **shutdown** in an emergency (See Page 10).

The Klean Sweep 1214 Series will be powered by either a 3:1 chain reducer drive, or a 4:1 gear reducer drive, depending on the bin diameter (the 3:1 for bins with diameters of 36' to 78' and the 4:1 for bins with diameters of 80' to 120').

The kit includes a motor mount and drive assembly, sweep flight and sweep shields, a drive reducer gearbox and a sweep tractor.

The unit will operate in a round bin that has been equipped with a center well.

Our augers are well made and we are proud of our line of equipment. We would like you, as our customer, to do your part in using caution and good judgement in using our equipment, as well as any other machinery.

DESIGNATED WORK AREA



WARNING! Under no circumstances should persons not involved in the operation be allowed to trespass into the work area.

It shall be the duty of all operator's to see that children and/or other persons stay out of the work areas.



Trespassing into the work area by anyone not involved in the actual operation, or trespassing into a hazard area by anyone shall result in immediate shutdown by the operator.



It shall be the responsibility of the operator's to see that the work area has secure footing, is clean and free of all debris and tools which might cause accidental tripping and/or falling.



It shall also be their responsibility to keep the work area clean and orderly during the operation.

- Before starting auger operations, a designated work area should be established around the bin and entire work site.
- Be cautious when working with electrical tools and equipment, especially around metal structures.
- Wear the appropriate personal protective gear when necessary, i.e. safety glasses, gloves, hearing protection, etc.

ELECTRIC MOTOR DRIVES



WARNING! A main power disconnect switch that can be locked only in the “OFF” position shall be provided. This shall be locked whenever work is being done on the Horizontal Bin Unloading Auger or any power driven equipment

Make certain the electric motor is grounded properly.

The electric drive motor and motor pulley are **not included** and will need to be obtained separately.

Always use a motor with required H.P. suggested in the table below. Use a 60 hz electric motor that operates at 1750 RPM (50 hz @ 1460 RPM). Too small of a motor will not supply the horsepower required to run at capacity and damage to the motor could occur. Too large of a motor may cause high stress on the conveyor components resulting in shorter life for them components.

Electric motors and controls shall be installed by a qualified electrician and must meet the standards set by the National Electrical Code and all local and state codes.

A magnetic starter should be used to protect your motor when starting and stopping. It should stop the motor in case of power interruption, conductor fault, low voltage, circuit interruption or motor overload. Then the motor must be restarted manually. Some motors have built-in thermal overload protection. If this type motor is used, use only those with manual reset.

HORSEPOWER REQUIREMENTS and SWEEP AUGER SPEEDS

These sweep augers were designed to match the unloading capacity of 12” unloading systems. The electric drive motor and motor pulley are **not included** and must be obtained separately.

Use the table below to determine the horsepower and motor pulley size your application requires.

The horsepower recommendations are based on clean, dry shelled corn or wheat.

High moisture grain (above 15%) will require greater power. The maximum possible capacity will be less with high moisture grain than with dry grain. Use the table below to determine size of motor required.

Horsepower Requirement Chart

Bin Diameter	H.P. (Electric)	Motor Pulley	Operating Flight Speed	Number of Belts
36 to 39 ft	7 1/2 HP (5.5 kw)	4 1/2” O.D. (11.4 cm)	218 RPM	2B
40 to 49 ft	10 HP (7.5 kw)	4 1/2” O.D. (11.4 cm)	218 RPM	3B
54 to 78 ft	15 HP (11 kw)	4 1/2” O.D. (11.4 cm)	218 RPM	3B
80 to 105 ft	20 HP (15 kw)	5.6” P.D. (14.2 cm)	223 RPM	3B
113 to 120 ft	25 HP (18.5 kw)	5.6” P.D. (14.2 cm)	223 RPM	3B

Motor pulleys are not furnished with the auger.

P.D. = Pitch Diameter

O.D. = Outside Diameter

OPERATING CAPACITIES

The performance of augers can vary greatly due to operating conditions. Different materials, moisture content, amount of foreign matter, methods of feeding and speed all play a role in the performance of the auger. Twenty-five (25%) moisture could cut capacity back by as much as 40% under some conditions.

GENERAL INFORMATION

START-UP INFORMATION

 **WARNING!** Make certain everyone is clear before operating equipment.

 The operator shall be aware of any unusual vibrations, noises and the loosening of fasteners.

 Keep all safety shields and devices in place.

 Keep hands, feet and clothing away from moving parts.

 Shut off and lock-out power to adjust, service or clean any powered equipment.

Refer to the Owner's & Operator's Manual provided with the bin unload system for proper procedures and operation of the bin unload system.

- Always be aware of the surrounding work area when starting any of the equipment. Make sure all persons are clear and all tools and loose materials are cleaned from the area.
- Assure all electrical connections and cords are properly secured. Know the proper procedures for Shut Down and Lockout (See Page 10).
- Use proper bin unloading procedures to remove as much grain from the bin as possible.
- During the operation of the auger, one person shall be in a position to monitor the operation at all times. **Do Not** leave the unit operating unattended.
- Inspect the drive before adding power and know how to shut down in an emergency (See Page 10). Visually inspect the auger periodically during operation

 **WARNING!** Do Not enter the grain bin unless all power driven equipment has been shut down and locked out.

 Never enter the grain bin unless monitored by another person.

 **DANGER!** Do Not enter the grain bin if the grain has not flowed out normally, or if it has created a "Bridging" affect as shown in Fig. 1. The grain may suddenly break loose and bury causing suffocation.



BIN UNLOADING INFORMATION

IMPORTANT! Before filling the grain bin, make sure all wells gates are closed. If the gates are left open, the wells will fill up with grain. Upon start-up, the unload auger would be under load, this can result in damage to the auger, motor, or both. Such damage is considered abuse and is not covered by warranty.

TO START BIN UNLOAD AUGER

1. Make sure all bin well gates have been closed and start the under-floor unloading auger.
2. Open the center well gate gradually until desired flow is established [you should only need to open the gate approx. 3 to 6 inches (7.6 cm to 15.2 cm) to acquire a full load].

Do Not overload the auger. This can cause high torque loads and possible damage to the auger. This kind of damage is not covered under warranty.

TO STOP BIN UNLOAD AUGER

1. Once grain has stopped flowing through the center well, close the well gate and allow auger to empty **before** stopping the motor.
2. Once auger is clear, shut off the electric motor and lockout the power source.

The grain remaining in the bin should appear as the normal flow illustration in Fig. 1. **Do Not** enter the bin if the grain has created a "Bridging" affect or if it has flowed "Abnormally" as shown in Fig. 1.

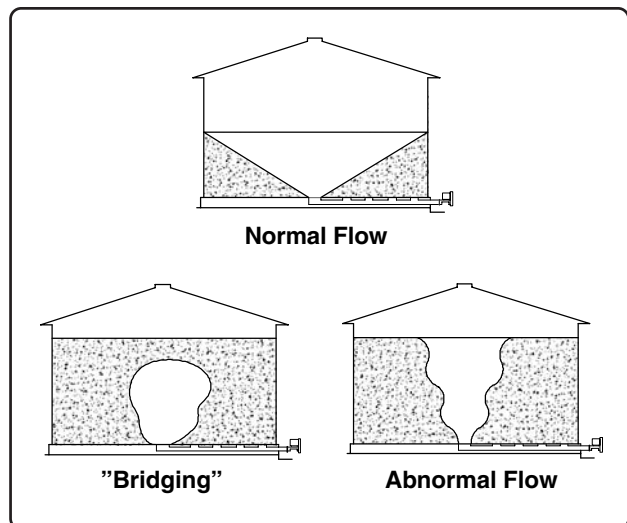

Fig. 1

INTERMEDIATE WELL INFORMATION

Refer to the Owner's & Operator's Manual provided with the bin unload system for proper bin unloading procedures and operation.

Some grain storage bins may use three intermediate wells, while others may use up to six. In either case, to avoid overloading the auger during unload operations, only open one or two intermediate well gates at a time. Allow them to flow clear before opening the next couple wells and so on (the illustration and instructions below use a bin with four intermediate wells as an example).

3. Start the unload auger and gradually open the first couple intermediate well gates nearest to the center well [you should only need to open the gates approx. 2 to 4 inches (5.1 cm to 10.2 cm) to acquire a full load]. When the grain flow stops, gradually open the next couple well gates and let them clean out as well. Continue this process until all gates have been opened and augered clean.

The Commercial Klean Sweep Auger and Tractor can now be installed in the bin.

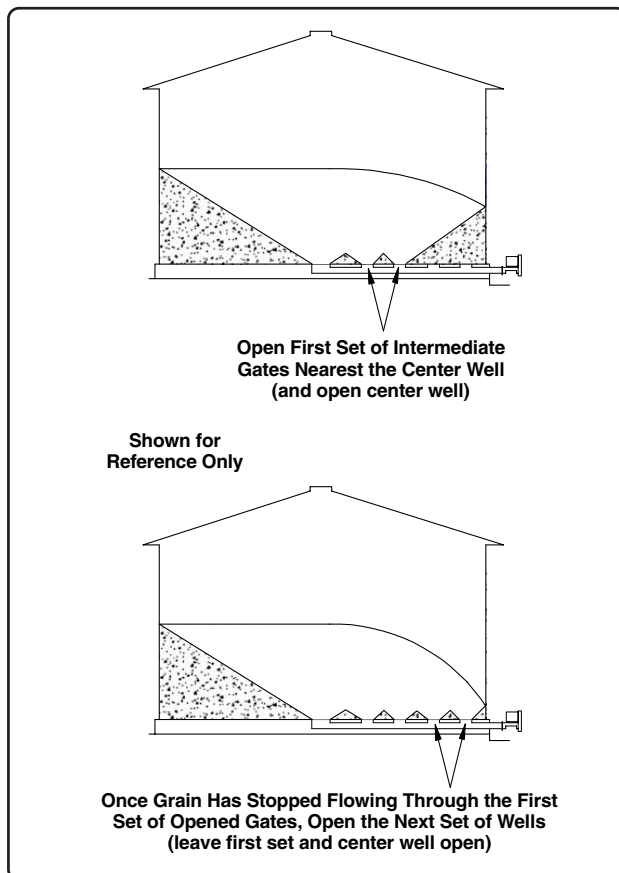

Fig. 2

INSTALLATION INFORMATION



Never enter the bin while the sweep is in operation. The sweep auger will move rapidly around the bin when the bin is nearly empty.



Do Not enter the bin unless all power equipment has been shut down and locked out.



Observe work area restrictions.

Make certain everyone is clear before operating the equipment.

Never enter the bin unless monitored by another person.

- **IMPORTANT!** the reducer drive gearboxes are shipped **without** oil. Oil must be added before operation. Refer to the lubrication section in this manual.
- The drive end of the Klean Sweep mounts to a pivot tube located on the center bin well. The sweep uses this pivot point and rotates around the bin.
- Each Klean Sweep is assembled with the sweep auger and sweep shield in one or more sections. Each section must be assembled in a particular order as shown in the chart on Page 18.
- Klean Sweep augers used in large diameter bins also use sweep carriers and truss cables for additional support (make sure to tuck the cable ends away so they do not become entangled in the sweep assembly).
- Once the sweep augers and shields have been assembled, the sweep tractor can be installed.
Note: Refer to the Sweep Flight Section Assembly instructions (Pages 26 to 32) for recommended tractor location. Check the location of the intermediate bin wells to ensure they are not in the direct path of the tractor. If they are, the tractor will need to be moved and new holes drilled in the shield for mounting (keep the tractor as close to its intended position as possible).
- The height of the sweep shields can be adjusted at the motor mount end and at each of the bolted connections between the shields.
The shield must be adjusted to clear the bin floor by at least 1" (25 mm), make sure the shields will clear splices in metal flooring or cracks in the concrete.

GENERAL INFORMATION

INSTALLATION INFORMATION (con't.)

- Attach suitable electric wiring to the motor in a manner that will allow the sweep to rotate several times around the bin.
- The motor starting controls must be located outside the bin (**they must never be installed on the sweep auger inside the bin**). Locate the motor starting controls (electrical box) outside the bin, but near the bin door so the operator has a full view of the operation inside the bin (See illustration below).
- Attach suitable electric wiring to the tractor motor. The wiring may either be connected with the sweep flight motor (the tractor will turn off and on with the sweep) or be on a separate circuit where the tractor may be started and stopped independently of the sweep auger. In either case, the tractor start and stop controls must be located outside of the bin.
- The sweep tractor can be adjusted to help improve traction during sweep operation. See Page 24, for information on adjustment procedures.

IMPORTANT! Klean Sweeps are NOT designed to remain in a bin during filling, storage or unloading. Leaving the sweep in the bin during these operations may cause severe damage to the sweep, center well, or bin. Hutchinson I Mayrath will not be responsible for such damage.

A typical installation (**recommended**) will use a single connection for the electric motor and a single connection for the tractor. This will allow the tractor to be started and stopped independently from the auger. The illustration shows this particular type of connection.

An alternate installation may use only one cord for both the tractor and electric motor. However, this would allow the tractor and auger to be started and shut down at the same time.

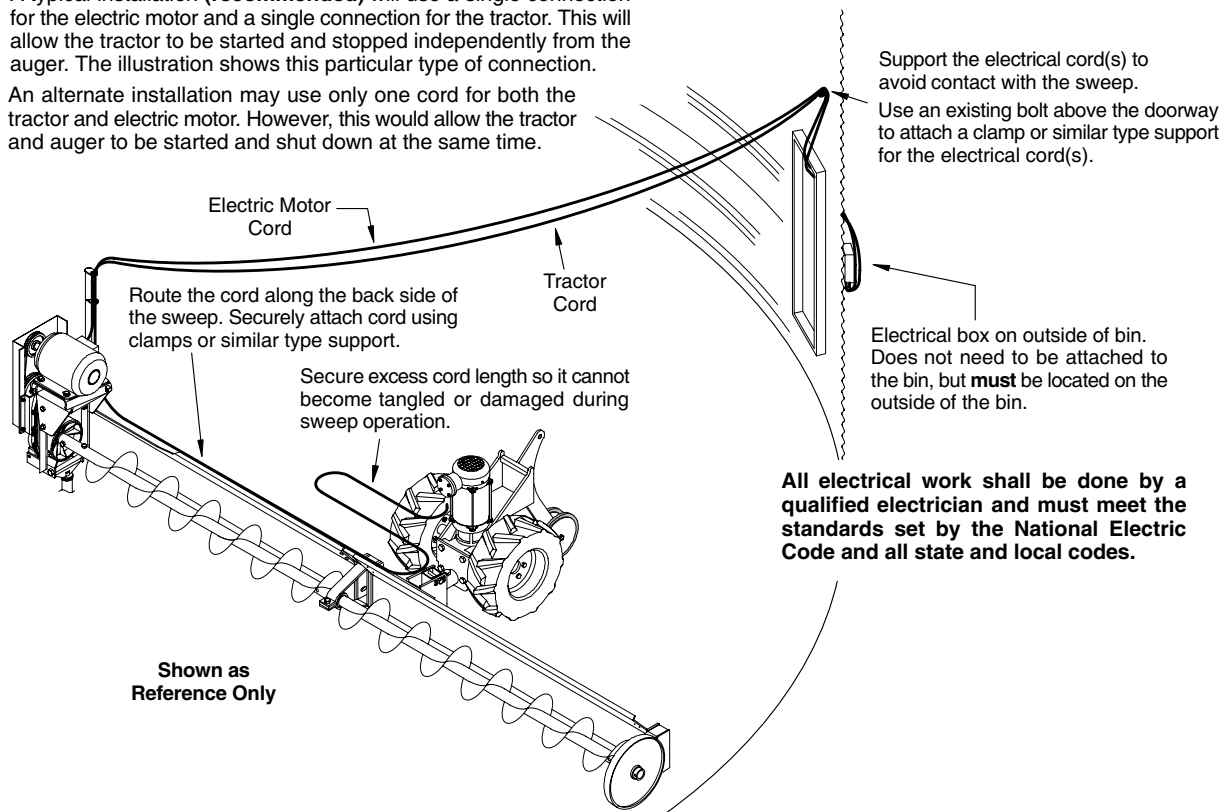

OPERATION



WARNING! Observe all designated work area restrictions.

Make certain everyone is clear before operating the equipment.



Never attempt to control the operation of the sweep auger by pushing on it with brooms, shovels or other devices.

Do Not attempt to restrain movement of the sweep auger by attaching ropes, bars, or other devices to be held by the operator.



Stay clear of the under-floor unloading auger at the bin wells. The unloader is exposed at these locations in the bin floor.

Check to see that all persons, tools and loose materials are out of the bin.

Inspect the assembled sweep auger. Check all hardware for tightness and make sure all electrical wiring and connections are secure.

Make sure oil has been added to the gearbox.

SWEEP AUGER START-UP

1. With center well gate open, start the under-floor unload auger first, then start the sweep auger.

The sweep auger will direct the grain towards the center well opening as it makes it travels around the bin.

As the amount of grain is reduced, the sweep will begin to move more rapidly.

Never enter the bin to move grain or work on the sweep assembly unless power has been shut down and locked out.

2. Once the sweep has cleared as much grain as possible from the bin, shut down the sweep, but let the unload auger continue running until all grain has been discharged, then **shut down and lockout the power source.**

The remaining grain can now to be completely removed from the bin. Refer to the following instructions for the final clean out of the bin.

FINAL CLEANOUT



WARNING! Never enter the bin unless all power equipment has been shutdown and the power source locked out.

The following procedure is recommended for cleaning the floor of the bin after the sweep auger has removed as much grain as possible.

1. With the power source locked out, clean (scoop and sweep by hand) the grain from the outer area of the bin floor into a circular pile towards the center of the bin (See Fig. 3).

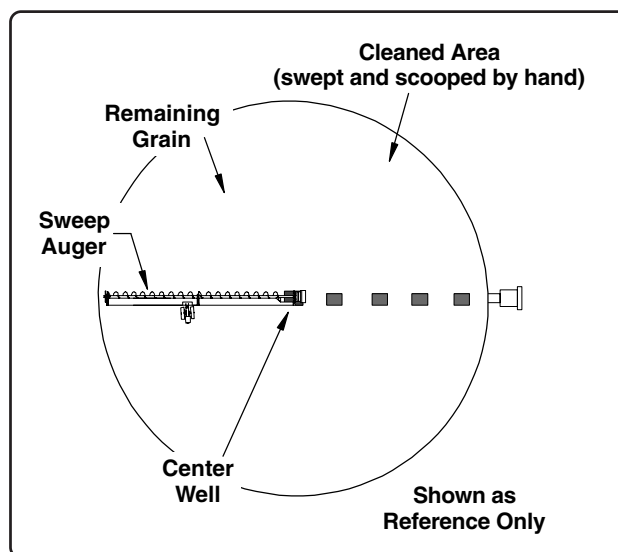

Fig. 3

2. Make sure all persons and equipment are out of the bin. Start the under-floor unload auger, *then* start the sweep auger. In a short time, the pile of grain will have been depleted.
3. Stop the sweep auger and let the unload auger clear. **Shut down and lockout the power source.**
4. Scoop and sweep the remaining grain in a pile towards the center of the bin as done previously.
5. Repeat Steps 2 thru 4 until all grain has been removed from the bin (the final bit of grain can be swept into the center well and removed with the unload auger).

OPERATING PROCEDURES

SHUTDOWN/LOCKOUT



WARNING! Starting the unit under load may result in damage to the auger and/or motor. Such damage is considered abuse of the equipment and will not be covered under warranty.



If the operator must leave the work area, or whenever servicing or adjusting, the auger must be stopped and the power source locked out.



Precaution should be made to prevent anyone from starting or operating the auger when the operator is absent from the work area.

EMERGENCY SHUTDOWN

Should either auger need to be immediately shutdown, **immediately** shut power “Off” and lockout the power source. Correct the cause of the shutdown, reconnect power and continue unloading operations.

If shutdown occurred because of an overload, close the center and intermediate well gates. Clear grain away from the discharge opening.

Reconnect the power source and run the auger to clear the grain gradually. **Never attempt to start when under load.**

NORMAL SHUTDOWN

When shutting down the auger, close all well gates and allow unloading auger to clean out before stopping the unit.

Before the operator leaves the work area, the power source shall be locked-out (See “Lockout”).

INTERMITTENT SHUTDOWN

When an auger is stopped and restarted while under full load, it may result in damage to the auger. Therefore if intermittent operation is to be carried out, it is advisable to reduce the load level.

If an auger is kept from absolute filling, it will make start-up easier and will convey grain more efficiently.

LOCKOUT

The power source shall have a main disconnect box that can be locked only in the “Off” position. This is what “shutdown and lockout” refers to, shut off the main power source and lock the handle or breaker switch in the “Off” position.

TROUBLE SHOOTING

LOW CAPACITY

- Sweep capacity may vary as the angle of sloping grain varies.

Check the horsepower requirements to determine correct operating speed and check motor pulley size recommended for that speed.

If a greater or lower capacity is desired, it may be possible to change the motor pulley, which in turn will change flight speed. **Do Not** attempt operation at speeds greater than 50 to 100 RPM's above the standard recommended speed.

Do Not operate a sweep that is overfeeding the unloading auger. The slide gate on the center bin well should be left open during sweep operation.

SWEEP FLIGHT & SHIELD NOT MOVING

- Check clearance between sweep shield and floor for excessive dragging and for obstacles that prevent the sweep from moving. Shield height can be adjusted using the slotted connections at each splice at bearing brackets.

The grain may have gone out of condition due to moisture or insect activity and has become hard or caked. Stop the sweep auger and lockout the power source before entering the bin to correct this or any other difficulty.

The electric motor may not be operating properly. Check electrical connections and power supply.

GRAIN PLUGGING UNLOAD AUGER

- The unload auger may be getting too much grain causing “jamming” inside the unload tube. **Shut down and lockout power source**, then clean as much grain from each of the wells and unload tube as possible. Reconnect power and restart unload auger operation.

If wet grain or other hard-to-move material is being augered, use a larger size motor than what is recommended for normal use (See Page 5).

Assure the auger is free of foreign material such as sacks, tarp corners etc. A plug at the discharge end of the unload tube will cause the unload auger to plug. **Shutdown and lockout power source before attempting to work on unit.**

4:1 REDUCER

 **WARNING!** Never attempt to clean, adjust or lubricate a machine that is in operation.

 Always shutdown and lockout the power source to all power driven equipment before servicing, repairing or maintaining any auger components.

IMPORTANT! The 4:1 reducer gearbox is shipped without oil. Oil needs to be added before operation. Even under normal working conditions, oil still has a tendency to dissipate. Periodically check oil level and maintain proper level.

1. With the gearbox in the upright position, remove the level check plug shown in Fig. 4 below.
Remove one of the plugs from the top of the gearbox, this will be used as the fill opening.
Add approx. 32 oz. (9.6 ml) of an SAE 80W90 weight oil through the plug opening on the top of the gearbox (a small funnel, pipe nipple or syringe type tool can be used to add the oil).
Watch the oil level check opening. When oil begins to leak from the opening stop adding oil. Do Not overfill. Additional oil may damage the seals or be forced through the vent plug.
Replace the level check plug once oil level has been established.
2. Discard the plug removed from the top of the gearbox fill opening and install the vent plug shipped separately with the gearbox (See Fig. 4).

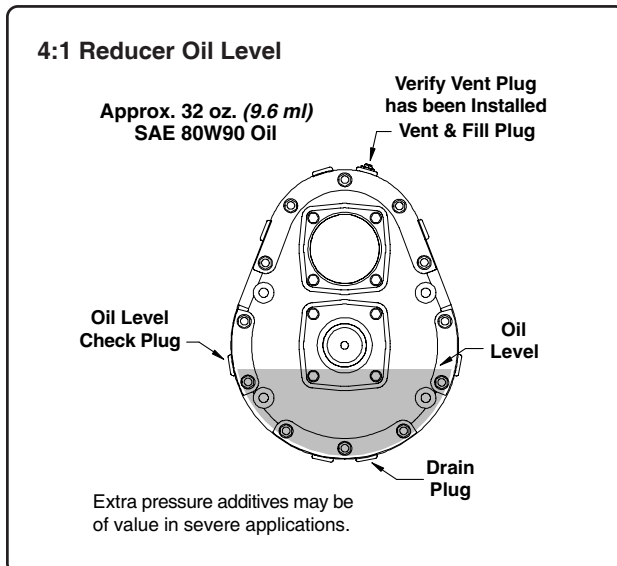



Fig. 4

3:1 REDUCER

 **WARNING!** Never attempt to clean, adjust or lubricate a machine that is in operation.

 Always shutdown and lockout the power source to all power driven equipment before servicing, repairing or maintaining any auger components.

IMPORTANT! The 3:1 reducer gearbox is shipped without oil. Oil needs to be added before operation. Even under normal working conditions, oil still has a tendency to dissipate. Periodically check oil level and maintain proper level.

1. With the gearbox in the upright position, remove the vented fill plug and the level check plug from the reducer housing (See Fig. 5). Clean the threads of the plug and apply teflon tape or a pipe sealant to the threads.
Add approximately 64 oz. (19.2 ml) of an SAE 90* weight oil, we recommend a non-foaming multipurpose gear oil (same as used commercially for automotive differentials).
Watch the oil level check opening. When oil begins to leak from the opening stop adding oil. Do Not overfill. Additional oil may damage the seals or be forced through the vent plug.
Replace the plugs once oil level has been established.

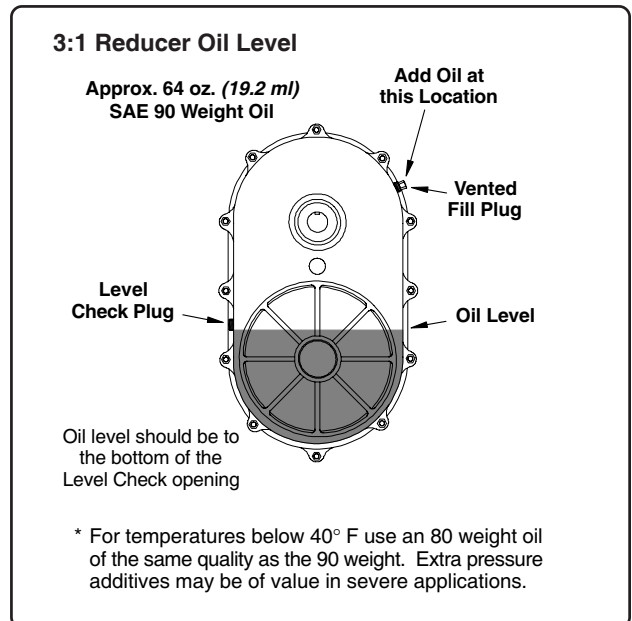

Fig. 5

LUBRICATION & MAINTENANCE

SWEEP MAINTENANCE



WARNING! Never attempt to clean, adjust or lubricate a machine that is in operation.



Always shutdown and lockout the power source to all power driven equipment before servicing, repairing or maintaining any auger components.



Never enter the bin unless all power driven equipment has been shutdown and locked out.

- Before each use, check to ensure all fasteners are tight and all guards are in place and secured.
- Inspect all electrical cords for damage, replace as necessary. Check all electrical connections to ensure they are tight and properly connected.

Electric motors and controls shall be installed by a qualified electrician and must meet the standards set by the National Electric Code and all local and state codes.

BEARING STAND BRONZE BUSHING

The bearing stands have a bronze bushing that the sweep fight connecting stubs pass through. Although these bushings require no lubrication, they can begin to wear over time.

This can cause the bushing to become oval shaped, or the bushing may begin to spin within the bearing support. If necessary, remove the worn bushing and press in a new one.

SWEEP TRACTOR

- Check that all fasteners and wheel lug bolts are tight.
- Make sure electrical cord is not damaged and ensure electrical connections are tight.
- Ensure weights (if applicable) are properly hung and secured to the main frame.
- Maintain proper tire pressure. Maximum tire pressure is **23 PSI (159 kPa)**.

DRIVE BELT ADJUSTMENT

Drive belts should be checked before each use for any damage such as fraying, cracking etc. Replace as necessary.

Remove the two bolts securing the belt guard door to gain access to the belts.

Check belts for proper tension. Belts should deflect approximately **1/2" (13 mm)** when firmly pressed at the center of the span between the two pulleys.

To adjust belt tension:

1. Loosen the 3/4" nut on the bottom of the threaded adjustment rod (the nut is located beneath the mount frame, See Fig. 6). Loosen the nut enough to allow the threaded rod to be adjusted accordingly.

Turn the nut welded to the top of the adjustment rod until proper belt tension has been achieved. Retighten the bottom nut securely against the bottom of the mount frame to lock adjustment rod in place.

The illustration shows the 3:1 reducer as an example only. Belt adjustment for the 4:1 reducer is the same.

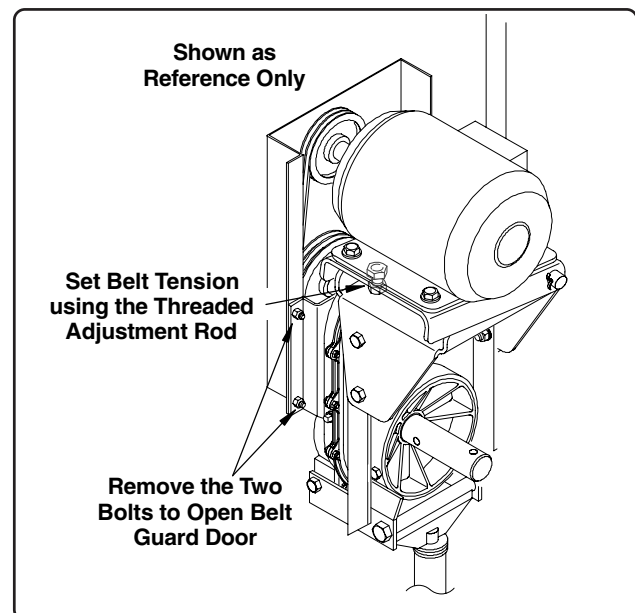

Fig. 6

3:1 CHAIN REDUCER DRIVE ASSEMBLY

for 36' to 78' Diameter Bins

For Bins above 78' in Diameter,
go to Page 15 (4:1 Reducer Assembly)



WARNING! Some of the components used in assembly are heavy. To avoid the possibility of personal injury, use assistance when assembling and lifting these parts.



Always wear the proper personal safety equipment when working with metal materials and power tools.



Be cautious of electrical hazards. Keep work area clean and free from tools and objects which may cause accidental tripping or falling.

IMPORTANT! The reducer gearbox is shipped without oil. Refer to the Lubrication section on Page 11 for instructions on adding oil.

1. Install the pivot bracket to the bottom of the gearbox mount frame and secure using a 3/4" x 11" bolt and nylon locknut (tighten only enough to still allow the bracket to pivot freely, See illustration below).

2. Attach the cord holder and motor mount support plate to the gearbox mount frame. Secure the cord holder side using two (2) 1/2" x 1 1/2" bolts, lock washers and non-lock nuts. Secure the other side of the support plate using two (2) 1/2" x 1 1/4" bolts, lock washers and non-lock nuts.
3. Mount the reducer gearbox to the mounting ring on the reducer mount plate and secure using four (4) 3/8" x 1" bolts and nylon locknuts.
4. Thread the adjustment rod down through the nut on top of the motor mount support until it extends two to three inches above the top of the support. Thread the 3/4" non-lock nut onto the bottom side of the adjustment rod, do not tighten at this time (final adjustment will be done after installing the motor and belts).
5. Position the motor mount plate over the top of the support plate aligning the pivot shaft holes with the shaft holes in the motor mount (See illustration below). Insert the pivot shaft through the holes and secure using two 3/16" x 1 1/2" cotter pins.

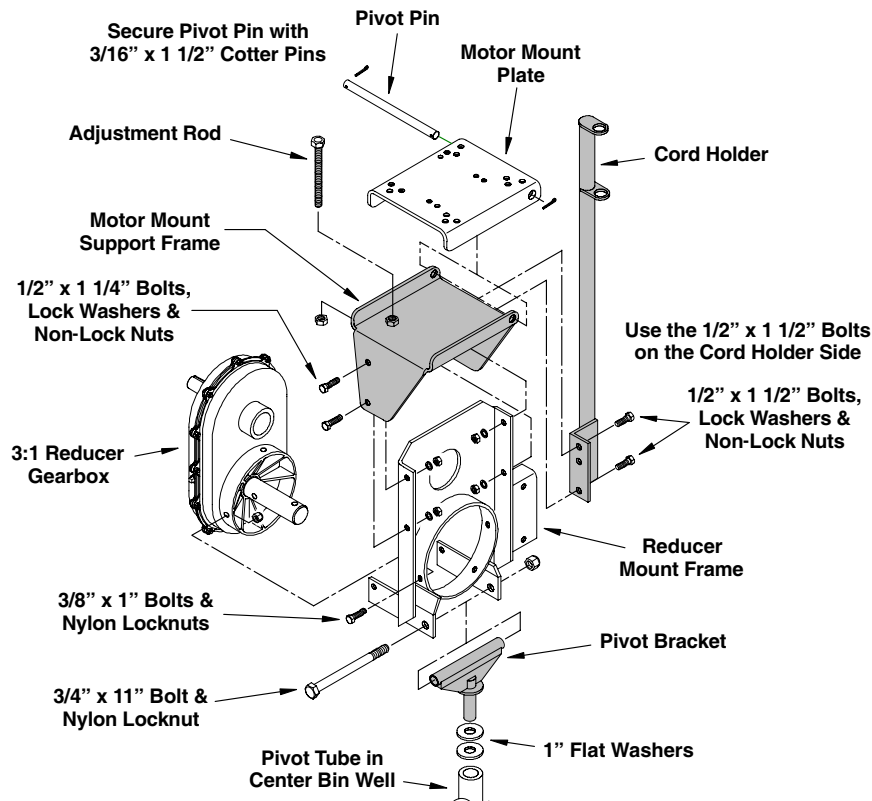

ASSEMBLY INSTRUCTIONS

3:1 CHAIN REDUCER FOR 1214 SERIES COMMERCIAL KLEAN SWEEP (con't.)

6. Install the belt shield onto the input shaft side of the gearbox. Slide the mounting ring of the belt shield over the mount ring on the reducer gearbox. Secure belt shield to the gearbox using four (4) 3/8" x 1" bolts and nylon locknuts.

(Don't tighten the hardware completely at this time, you want to allow the shield to have enough movement to later install the spacers that go between the shield and the gearbox mount plate).

7. Fasten the bottom of the shield to the mount tabs on the gearbox mount plate (See Fig. 7).

Place a 3/8" x 1/4" thick flat washer between the shield and the gearbox mount plate tabs and secure using two (2) 3/8" x 1 1/4" bolts and nylon locknuts. Do not tighten these completely at this time.

8. The spacers will be located at the upper portion of the shield (See Fig. 7). Position the spacers between the belt shield and mount plate and secure using the 1/4" x 5" bolts and nylon locknuts provided. Tighten the four bolts securing the belt shield to the gearbox, the two bottom bolts, then the spacer bolts.

9. Install the electric motor onto the motor mount plate. **Note: the motor, its mounting bolts and the motor pulley are not furnished.** Refer to Fig. 7 below for appropriate motor size and bolt hole locations.

10. Install the motor pulley onto the motor shaft and secure according to the instructions included with the pulley.

11. Slide the 12" O.D. pulley and the 1/4" sq. x 3" long key onto the input shaft of the gearbox. Align the input shaft pulley and motor pulley by placing a straight edge on the face of each pulley. Once pulley's are aligned, tighten the set screw on the input shaft pulley to secure into place.

12. Install the belts set tension (Refer to Page 12 for proper belt adjustment). Once belts are tight, secure the nut on the bottom side of the adjustment rod tightly against the bottom of the support plate.

13. Close the belt shield door and secure using two (2) 3/8" x 3/4" bolts and nylon locknuts.

14. Install the electric cord clamp onto the lower tab of the cord holder. Secure with jam nut provided.

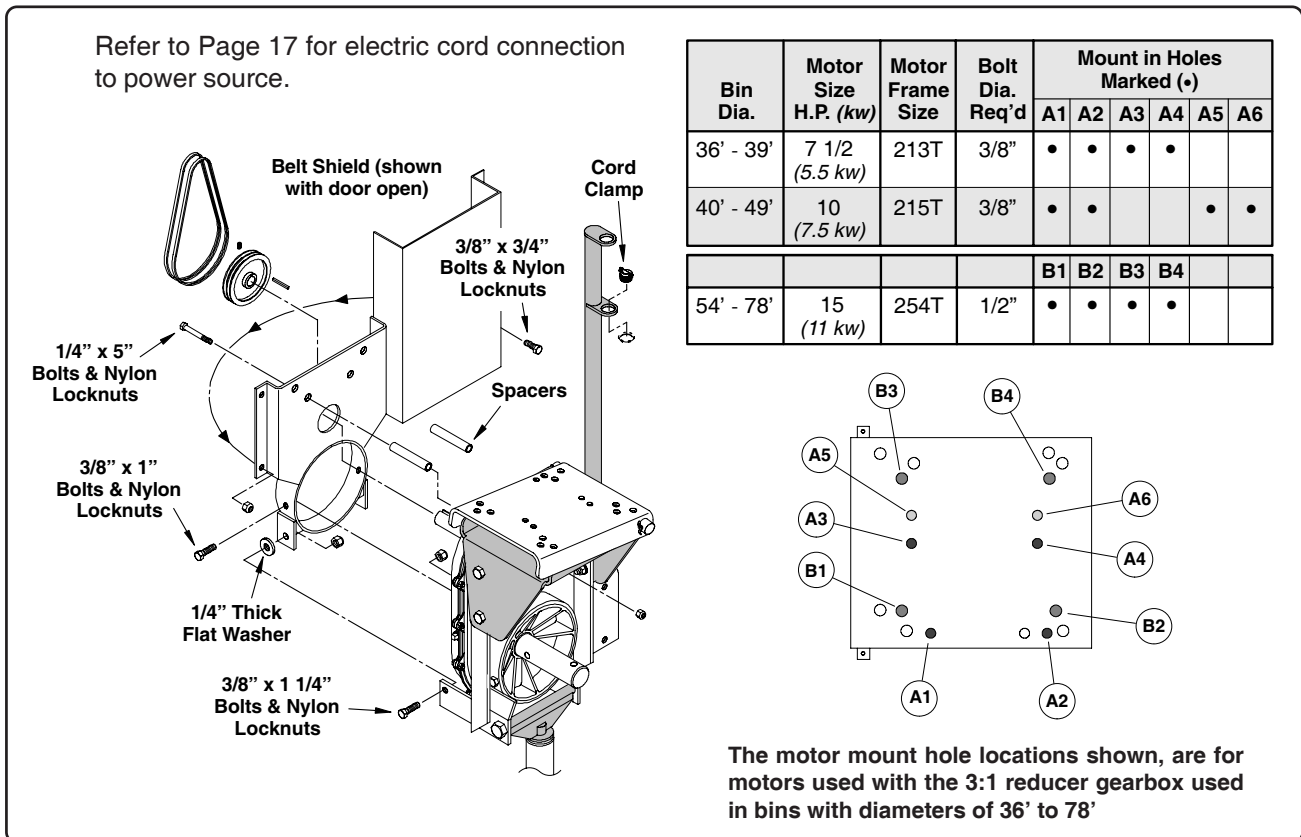



Fig. 7

4:1 GEAR REDUCER DRIVE ASSEMBLY for 80' to 120' Diameter Bins



Some of the components used in assembly are heavy. To avoid the possibility of personal injury, use assistance when assembling and lifting these parts.



Always wear the proper personal safety equipment when working with metal materials and power tools.



Be cautious of electrical hazards. Keep work area clean and free from tools and objects which may cause accidental tripping or falling.

IMPORTANT! The reducer gearbox is shipped without oil. Make sure oil has been added before continuing with the following assembly procedures (Refer to Page 11 in Lubrication & Maintenance Section).

1. Install the pivot bracket to the bottom of the gearbox mount frame. Secure using a 3/4" x 11" bolt and nylon locknut (tighten only enough to still allow the bracket to pivot freely, See illustration below). Slide two 1" flat washers onto the rod at the bottom of the bracket and insert the rod into the pivot tube located in the center bin well.

2. Attach the gearbox to the gearbox mount frame and secure using the four (4) 3/8" x 4" bolts and lock washers provided (the mount frame will attach to the output shaft side of the gearbox).
3. Attach the motor mount support plate and cord holder to the gearbox mount frame (the cord holder will mount on the outside of the support plate). Secure the side with the cord holder using two (2) 1/2" x 1 1/2" bolts, lock washers and non-lock nuts. Secure the other side of the support plate using two (2) 1/2" x 1 1/4" bolts, lock washers and non-lock nuts (See illustration below).
4. Thread the adjustment rod down through the nut on top of the motor mount support until it extends two to three inches above the support. Thread the 3/4" non-lock nut onto the bottom side of the adjustment rod, do not tighten (final adjustment will be done after installing the motor and belts).
5. Position the motor mount plate over the top of the support plate aligning the pivot shaft holes with the shaft holes in the motor mount (See illustration below). Insert the pivot pin through the holes and secure using two 3/16" x 1 1/2" cotter pins.

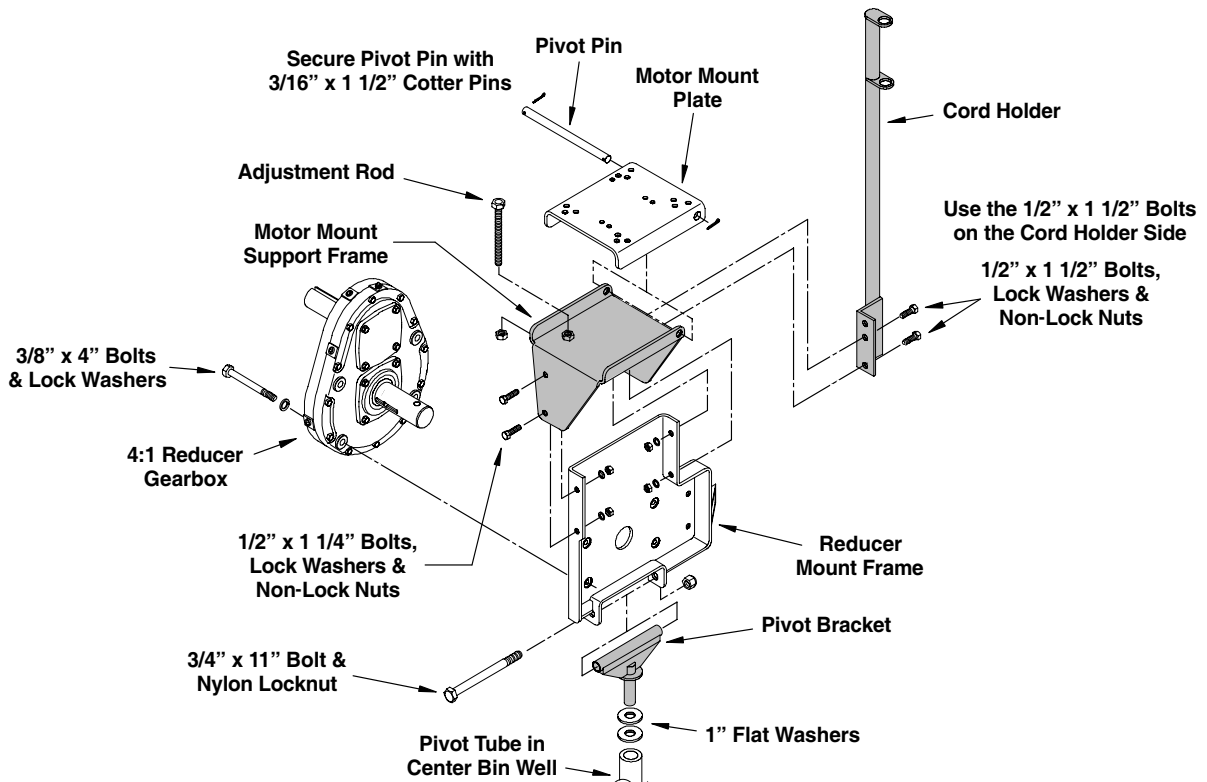

ASSEMBLY INSTRUCTIONS

4:1 CHAIN REDUCER FOR 1214 SERIES COMMERCIAL KLEAN SWEEP (con't.)

6. Install the electric motor onto the motor mount plate.
Note: the motor, its mounting bolts and the motor pulley are not furnished. Refer to Fig. 8 below for appropriate motor size and bolt hole locations.

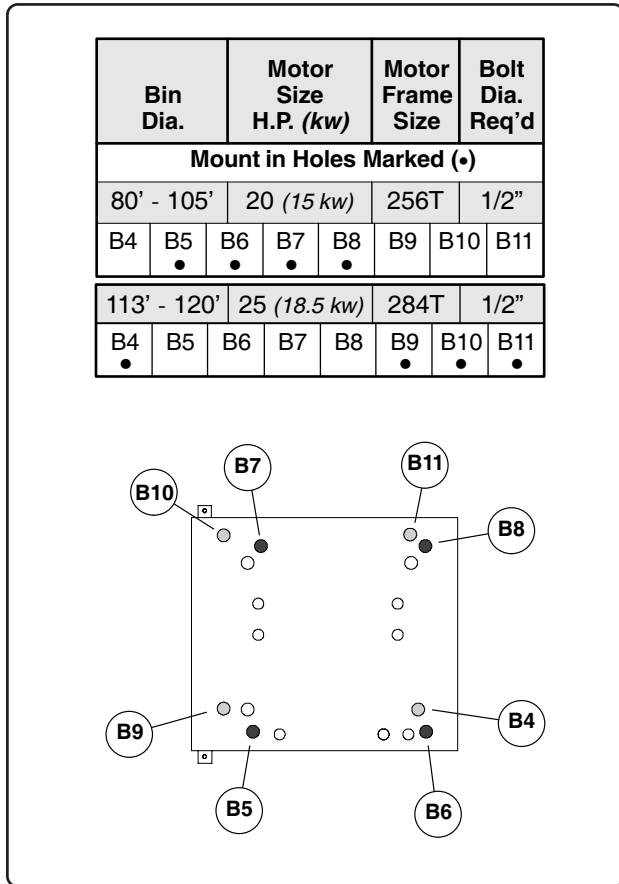

Fig. 8

7. Install the motor pulley onto the motor shaft and secure according to the instructions and hardware included with the pulley.
8. Slide the 11.0" P.D. pulley, 3/8" x 1 1/2" key and the QD tapered bushing onto the input shaft of the reducer gearbox. Align the input shaft pulley and motor pulley by placing a straight edge on the face of each pulley. Once pulley's are aligned, tighten the hardware securing each pulley into place.
9. Install the belts and tighten by adjusting the threaded rod against the bottom of the motor mount plate (Refer to Page 12 for belt adjustment). Once belts are tight, secure the nut on the bottom side of the adjustment rod tightly against the bottom of the support plate.

10. The belt shield will mount on the input shaft side of the gearbox. Loosen the four 3/8" x 4" long bolts that attach the gearbox to its mount plate (the bolts only need to be loose enough to allow the thickness of the belt shield panel to fit behind the bolt head and lock washer).

Align the two upper mounting holes in the shield with the bolt heads on the gearbox. Once the shield is past the bolt head and lock washer, slide it down until the bottom and top slots are resting on the bolts. Retighten the bolts (See Fig. 9).

11. Close the belt shield door and secure using two (2) 3/8" x 3/4" bolts and nylon locknuts.
12. Install the electric cord clamp onto the lower tab of the cord holder. Secure with jam nut provided. Refer to Page 17 for electric cord connection to power source.

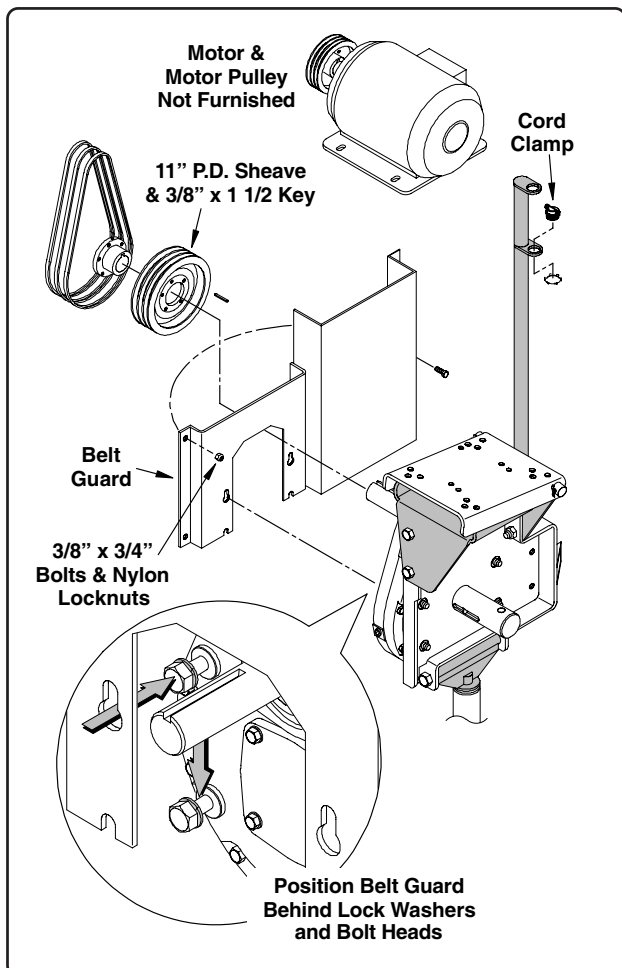

Fig. 9

ELECTRIC MOTOR CONNECTION



WARNING! A main power disconnect switch that can be locked in only the “Off” position shall be used. This shall be locked whenever work is being done to any of the power driven equipment.

The reset and starting controls must be located outside the bin and in a location so that the operator has full view of the entire operation.

Make certain electric motor is properly grounded.



Do Not enter the grain bin while the sweep is in operation. Always shutdown and lock out all power driven equipment before entering the bin.

Shutdown and lock out the power source before cleaning or servicing any of the power driven equipment.

Electrical connections shall be made by a qualified electrician and must meet the standards set by the National Electrical Code and all state and local codes.

The routing of the electrical cord and connection to the power source is the same no matter which reducer gearbox is used.

1. After connecting the power cord to the electric motor, route the cord from the motor through the cord clamp and through the ring on top of the cord holder.
2. Leave a small loop of electrical cord between the motor and the cord clamp (See Fig. 10). Tighten the clamp to secure the cord into place. Keep in mind the tractor's electrical cord will also pass through the cord clamp.
3. Route the electrical cord to the power source. Make sure to keep the cord high enough so it cannot become entangled in the sweep as it travels around the bin. One method is to use an existing bolt above the doorway to attach a clamp or similar type support in which to attach the cord to. The tractor's electrical cord will also need to be supported in such a manner.

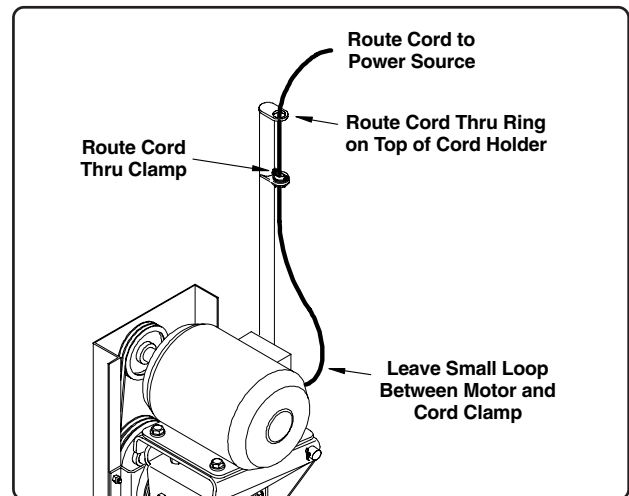
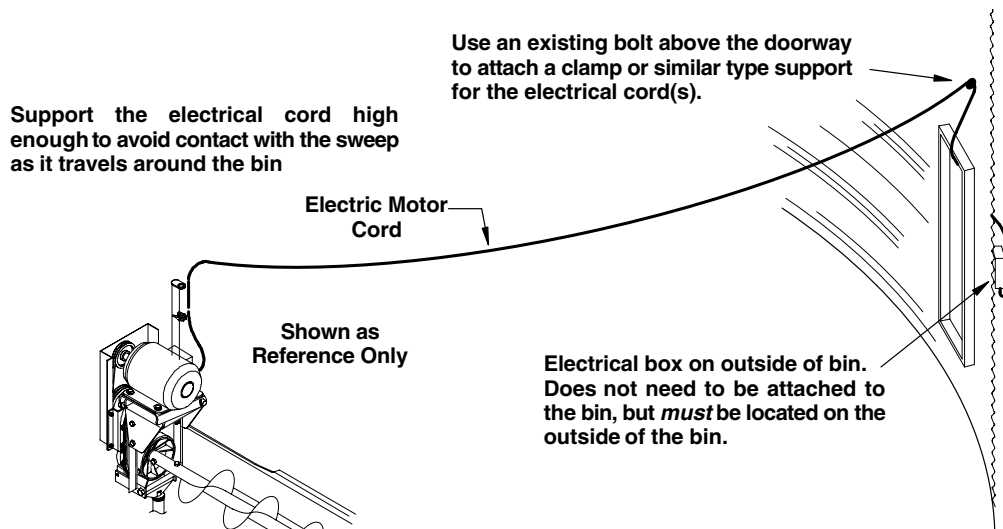

Fig. 10



ASSEMBLY INSTRUCTIONS

SWEEP FLIGHT AND BACK SHIELD

ASSEMBLY

The Commercial Klean Sweep is made up of several sections of sweep flight and back shields. The length and number of sections will vary depending on bin size. The chart below shows the appropriate flight and shield lengths required for various bin sizes.

The sweep flight with the cutback must be attached to the drive assembly. The remaining sections should be assembled in the order shown in the chart below. The section furthest from the drive unit has mounting holes for the sweep tractor.

If a sweep auger with four or more sweep sections was selected, a truss assembly is included. The truss should be used anytime four or more sections are assembled together.

If the truss assembly you have is for a greater number of sweep sections than what you are assembling, be sure to either tie off, or cut off the extra cable length so it cannot become entangled in the sweep flight.

Catalog No.	Bin Dia.	1st Section (with Cutback) Attached to Drive Unit	2nd Section from Drive Unit	3rd Section from Drive Unit	4th Section from Drive Unit	5th Section from Drive Unit	6th Section from Drive Unit
BK1436SD	36'	9'-9 3/4" (2.99 m)	6'-7 1/2" (2.02 m)				
BK1437SD	37'	9'-9 3/4" (2.99 m)	7'-1 1/2" (2.17 m)				
BK1440SD	40'	9'-9 3/4" (2.99 m)	8'-7 1/2" (2.63 m)				
BK1442SD	42'	9'-9 3/4" (2.99 m)	9'-3 1/2" (2.83 m)				
BK1443SD	43'	9'-9 3/4" (2.99 m)	9'-9 3/4" (2.99 m)				
BK1448SD	48'	9'-9 3/4" (2.99 m)	7'-1 1/2" (2.17 m)	5'-3 1/2" (1.52 m)			
BK1449SD	49'	9'-9 3/4" (2.99 m)	8'-10" (2.69 m)	3'-9 1/2" (1.16 m)			
BK1454SD	54'	9'-9 3/4" (2.99 m)	8'-10" (2.69 m)	6'-7 1/2" (2.02 m)			
BK1455SD	55'	9'-9 3/4" (2.99 m)	8'-10" (2.69 m)	7'-1 1/2" (2.17 m)			
BK1459SD	59'	9'-9 3/4" (2.99 m)	9'-3 1/2" (2.83 m)	8'-7 1/2" (2.63 m)			
BK1460SD	60'	9'-9 3/4" (2.99 m)	9'-9 3/4" (2.99 m)	8'-7 1/2" (2.63 m)			
BK1462SD	62'	9'-9 3/4" (2.99 m)	9'-9 3/4" (2.99 m)	9'-3 1/2" (2.83 m)			
BK1468SD	68' *	9'-9 3/4" (2.99 m)	6'-7 1/2" (2.02 m)	8'-10" (2.69 m)	6'-7 1/2" (2.02 m)		
BK1472SD	72' *	9'-9 3/4" (2.99 m)	7'-1 1/2" (2.17 m)	9'-9 3/4" (2.99 m)	7'-1 1/2" (2.17 m)		
BK1475SD	75' *	9'-9 3/4" (2.99 m)	7'-1 1/2" (2.17 m)	9'-3 1/2" (2.83 m)	9'-3 1/2" (2.83 m)		
BK1478SD	78' *	9'-9 3/4" (2.99 m)	9'-3 1/2" (2.83 m)	9'-3 1/2" (2.83 m)	8'-7 1/2" (2.63 m)		
BK1480SD	80' *	9'-9 3/4" (2.99 m)	9'-9 3/4" (2.99 m)	9'-9 3/4" (2.99 m)	8'-7 1/2" (2.63 m)		
BK1488SD	88' *	9'-9 3/4" (2.99 m)	6'-7 1/2" (2.02 m)	8'-10" (2.69 m)	6'-7 1/2" (2.02 m)	9'-9 3/4" (2.99 m)	
BK1490SD	90' *	9'-9 3/4" (2.99 m)	3'-9 1/2" (1.16 m)	9'-9 3/4" (2.99 m)	9'-3 1/2" (2.83 m)	9'-9 3/4" (2.99 m)	
BK1492SD	92' *	9'-9 3/4" (2.99 m)	7'-1 1/2" (2.17 m)	8'-10" (2.69 m)	8'-10" (2.69 m)	8'-10" (2.69 m)	
BK14105SD	105' *	9'-9 3/4" (2.99 m)	5'-3 1/2" (1.52 m)	9'-9 3/4" (2.99 m)	9'-9 3/4" (2.99 m)	9'-9 3/4" (2.99 m)	5'-3 1/2" (1.52 m)
BK14113SD	113' *	9'-9 3/4" (2.99 m)	8'-10" (2.69 m)	9'-9 3/4" (2.99 m)	8'-10" (2.69 m)	9'-9 3/4" (2.99 m)	6'-7 1/2" (2.02 m)
BK14120SD	120' *	9'-9 3/4" (2.99 m)	9'-3 1/2" (2.83 m)	9'-9 3/4" (2.99 m)	9'-9 3/4" (2.99 m)	9'-9 3/4" (2.99 m)	8'-7 1/2" (2.63 m)

* Truss Assembly Required

SWEEP FLIGHT & BACK SHIELD (con't.)

PRE-ASSEMBLE BEARING STANDS

The bearing stands will be used at each shield-to-shield connection and at the end with the sweep end-wheel assembly. Pre-assemble the bearing stands as shown below and temporarily set them aside.

1. Position the bearing holder to the inside of the bearing stand as shown in Fig. 11. Secure using one 7/16" x 1 1/2" bolt and nylon locknut.

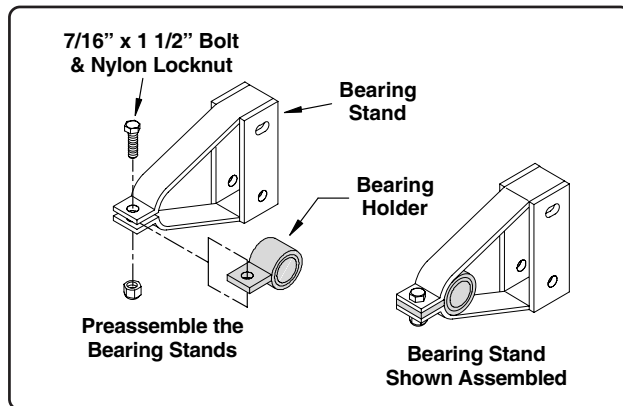

Fig. 11

ASSEMBLE FLIGHT AND SWEEP SHIELDS

Note the ends on the longer (or longest) sweep flight and shield section from the kit. One end of the flight has a small portion of auger cutback, this is the end that connects to the output shaft on the reducer gearbox (See Fig. 12).

One end of the sweep shield also has a cutback on it, this end will be attached to the shield mount bracket on the gearbox frame (See Fig. 12).

1. Apply anti-seize compound to the output shaft on the gearbox. Bolt the sweep flight (with cutback) to the shaft and secure using two 5/8" x 4" bolts and nylon locknuts.
2. **IMPORTANT! If using the 3:1 reducer gearbox with 4 or more sweep sections, a cable anchor bracket will also need to be installed when attaching the sweep shield to its mount bracket. The cable anchor will be positioned to the back side of the mount bracket**

Attach the first sweep shield (with cutback) to the mount bracket located on the gearbox frame (if using the 3:1 gearbox, also attach the cable anchor).

Secure the shield (and cable anchor if applicable) using two 3/8" x 1 1/2" bolts, one flat washer, and two lock washers and non-lock nuts (the flat washer is used over the slotted hole in the shield).

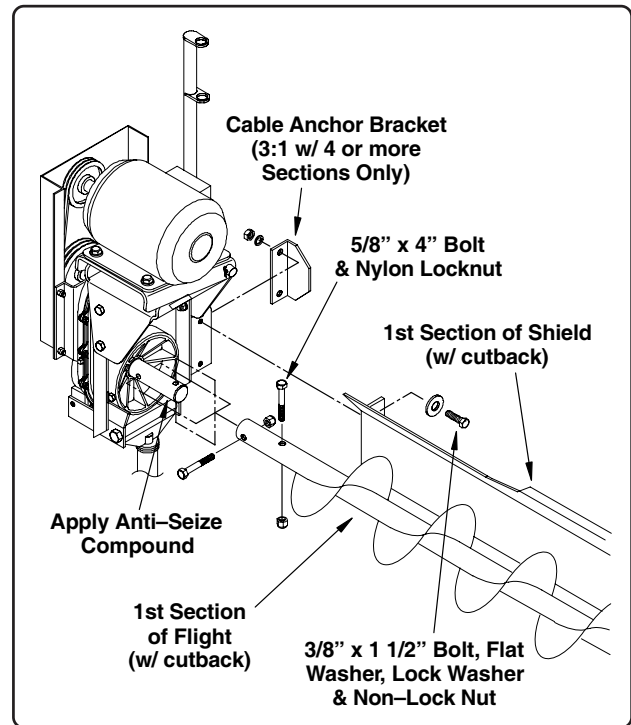

Fig. 12

3. Support the flight and shield with a wood block or similar item. Position a bearing stand assembly at the end of the shield and install the next section of sweep shield (the bearing stand will be sandwiched between the shields, See Fig. 13).
4. Secure the bearing stand using one 3/8" x 3" carriage bolt, flat washer, lock washer and non-lock nut through the slotted holes, and one 3/8" x 3" bolt, lock washer and non-lock nut through the bottom holes.

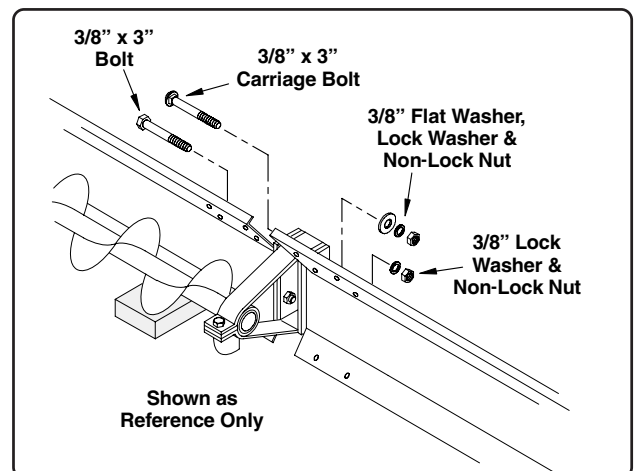

Fig. 13

ASSEMBLY INSTRUCTIONS

SWEEP FLIGHT & BACK SHIELDS (con't.)

- Attach the splice plates to the back of the sweep shield. Use eight 5/16" x 3/4" bolts and nylon locknuts on the upper splice plate (larger plate) and use four 5/16" x 3/4" bolts and nylon locknuts on the lower splice plate (small plate).
- Apply anti-seize compound to the stub on the end of the next flight section. Slide the stub through the bearing holder and into the first section of flight previously installed. Secure the flight sections using two 5/8 x 4" bolts and nylon locknuts.

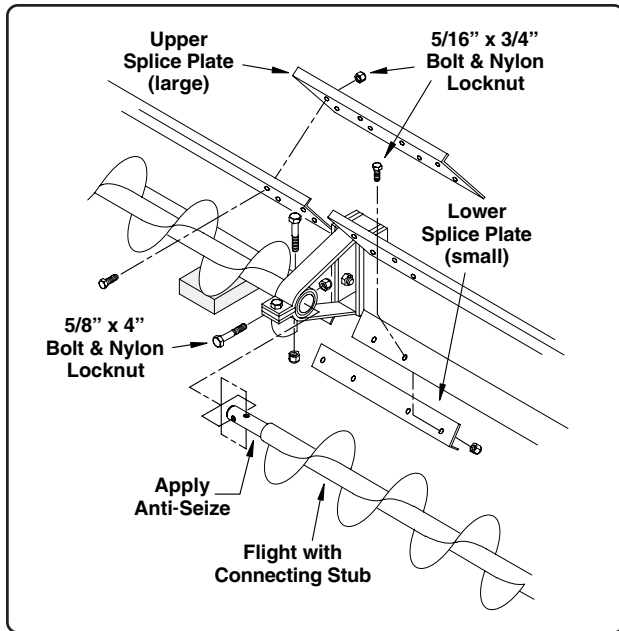

Fig. 14

NOTE: the sweep flights are indexed to achieve a "timed" connection (a "timed" connection is where the flight pitch does not change across the connection from one flight to the next). When bolting timed flight sections together, position flight ends as shown in Fig. 15.

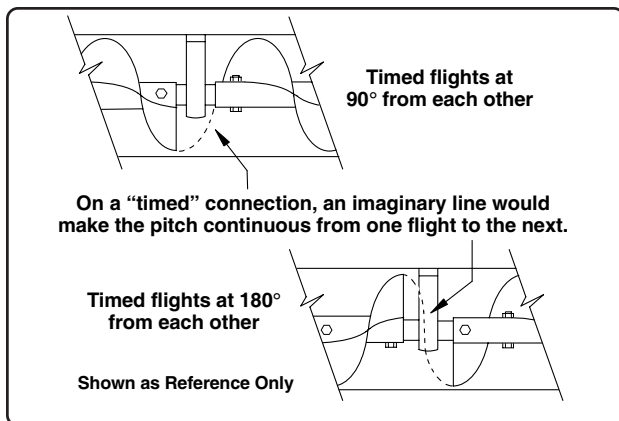

Fig. 15

- Repeat the procedures from Steps 3 thru 5 for additional sweep flight and shield add-ons. Once the last section of flight and shield has been installed, the end wheel and collar can be mounted (if using 4 or more flight sections, see the instructions for truss and carrier assembly beginning on Page 21).
- Position a bearing stand onto the end of the last shield and secure with the 3/8" x 3" carriage bolt and standard bolt as before (See Fig. 16). Apply anti-seize compound to the end wheel connecting stub. Insert the stub into the flight and secure using one 5/8 x 4" bolt and nylon locknut.

Slide the end wheel and collar onto the stub and secure the collar using one 1/2" x 3 1/4" bolt and nylon locknut.

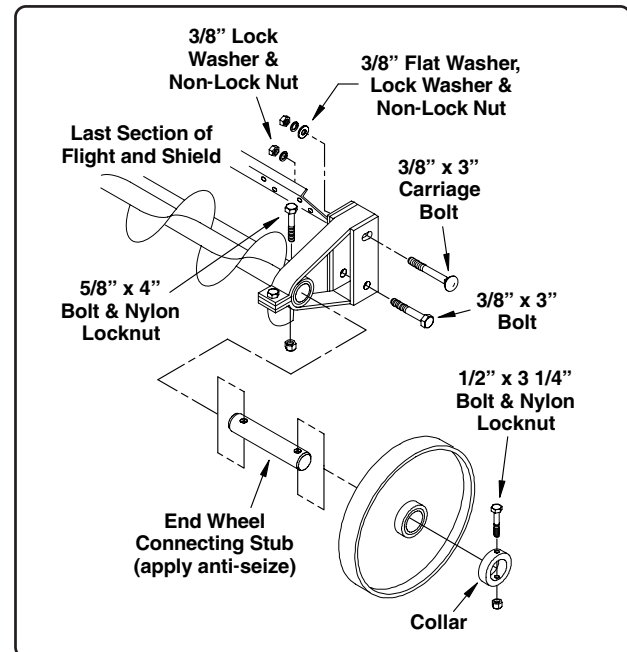

Fig. 16

If using 3 or less flight sections, the sweep tractor can now be installed. Refer to Page 23 for sweep tractor assembly and installation.

If using 4 or more flight sections, continue with the following procedures.

FLIGHT, SHIELD and TRUSS ASSEMBLY **for Units with 4 or More Flight Sections**

On units that use four or more sections of flight, a cable truss stand and carrier are provided.

With the 4, 5 and 6 section units the carrier and truss stand will be installed between the 2nd and 3rd flight sections.

The illustrations on Pages 26 to 32 give an overall view of each flight section unit. You can refer to them to help locate the carrier and cable anchor bracket during the assembly process.

After installation of the first two flight sections (previously outlined on Pages 19 to 20 in Steps 1 thru 6) the carrier, truss stand and cable anchor bracket can be installed.

For units using 4, 5 & 6 sections, install a carrier and truss stand between the 2nd & 3rd flight sections.

1. The carrier needs to have a bearing stand inserted between the mounting angles before the shields can be attached (See Fig. 17).

Insert the bearing stand and position the stand and carrier at the end of the flight section. Attach the next shield section and secure the shields to the carrier and bearing stand using two 3/8" x 3 1/2" bolts, flat washers, lock washers and non-lock nuts.

2. Attach the truss stand to the carrier (See Fig. 17) and secure using four 3/8" x 1" bolts, lock washers and non-lock nuts.

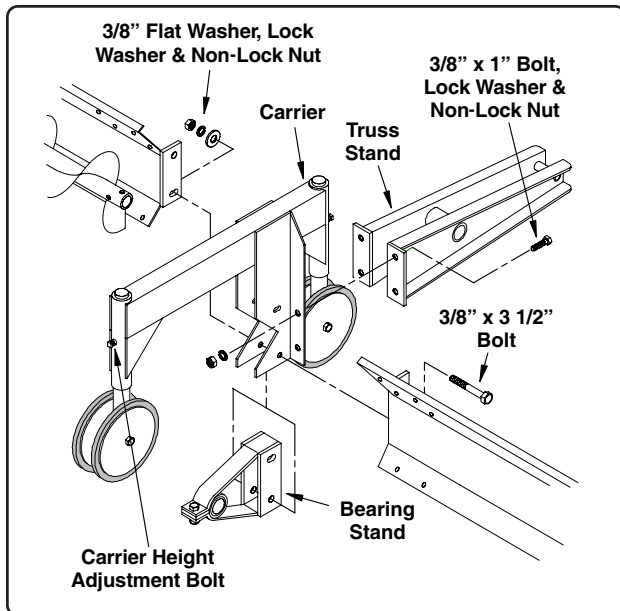

Fig. 17

3. Apply anti-seize compound to the stub on the next section of flight. Install the flight, sliding the stub end through the bearing holder and into the section of flight previously installed. Secure the flight sections using two 5/8" x 4" bolts and nylon locknuts. (See Fig. 14 on the previous page).
4. Install a bearing stand onto the end of the flight and shield section. Position the fourth shield and the cable anchor bracket (See Fig 18) against the bearing stand and secure using two 3/8" x 3 1/2" bolts, flat washers, lock washers and non-lock nuts.

On units using 4, 5 or 6 sweep sections, a cable anchor bracket will be attached with the shield to the bearing stand.

This anchor may be located at the splice of either the 3rd & 4th sections, or at the splice of the 4th & 5th sections.

Refer to the illustrations on Pages 29 to 32 for location of the cable anchor.

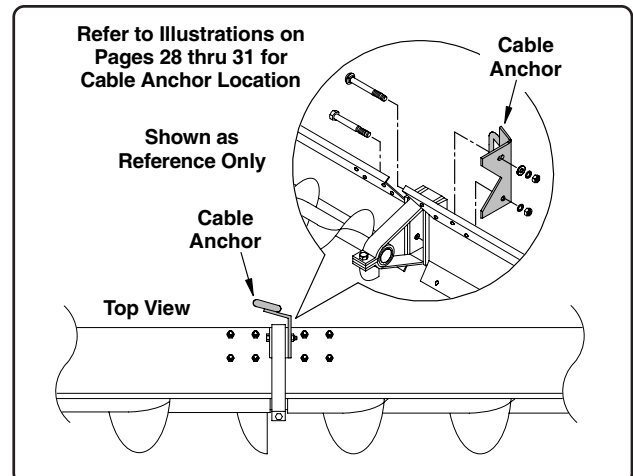

Fig. 18

5. Install the end wheel as outlined in Step 8 and shown in Fig. 16 on the previous page (Page 20).
6. Attach splice plates to the sweep shield where necessary (See Fig. 14 on Page 20 for reference). Use eight 5/16" x 3/4" bolts and nylon locknuts on the upper splice plate (the larger plate) and use four 5/16" x 3/4" bolts and nylon locknuts on the lower splice plate (small plate).

Continue with the truss cable assembly on the following page.

ASSEMBLY INSTRUCTIONS

INSTALL TRUSS CABLE

1. Attach one end of the cable to the loop on the cable anchor bracket previously installed at the sweep shield splice (See Fig. 19). Secure the cable using two 5/16" cable clamps.

IMPORTANT! Make sure the u-bolt portion of the clamp is against the loose end of the cable.

2. Route the cable through the small hole at the rear of the truss stand to the cable anchor bracket on the side of the gearbox frame (See Fig. 20).

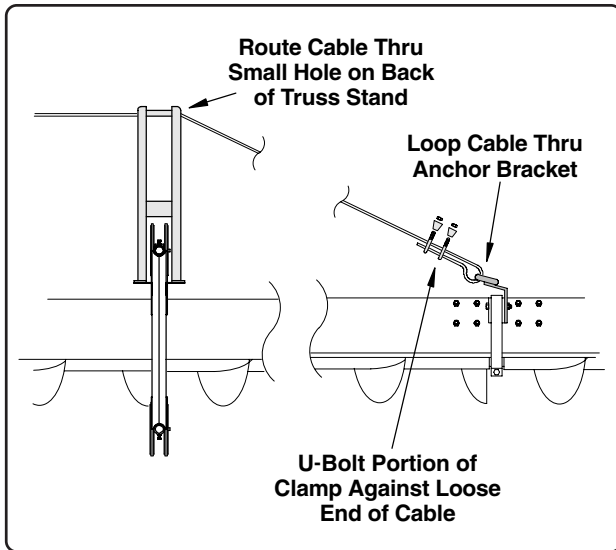

Fig. 19

3. Attach the 5/8" x 11" eyebolt to the cable anchor bracket on the side of the gearbox frame (part of the drive assembly in center well). Secure the eyebolt using one flat washer and two non-lock nuts (See Fig. 20).

Insert the cable thru the eyebolt, pull the cable snug and secure cable with the cable clamps provided.

IMPORTANT! When clamping the cable, position the u-bolts against the loose end of the cable.

4. Tighten the cable by adjusting the nuts on the eyebolt (cable should be reasonably tight). Once tight, tighten the bottom nut against the top nut to secure into place.

Make sure to tie back or cut off any excess cable so it cannot become entangled while the sweep is traveling around the bin.

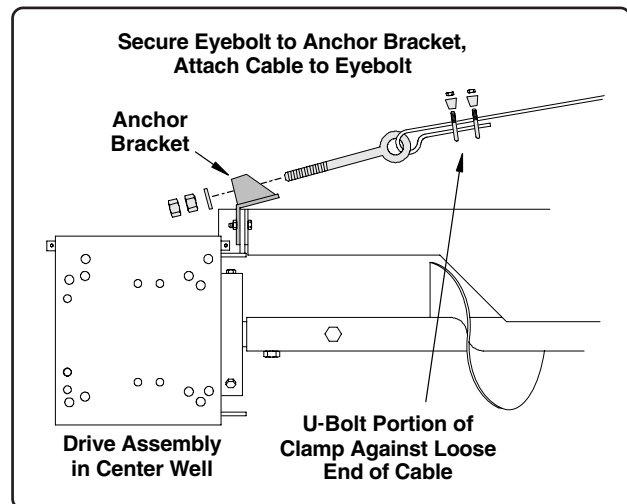

Fig. 20

Check the assembled sweep sections. Make sure all hardware is tight, and all Safety Decals are in place and legible.

If a decal cannot be read or is missing, they can be obtained free of charge from your Hutchinson/Mayrath dealer or ordered directly from the factory.

SWEEP TRACTOR ASSEMBLY

WARNING! Do Not enter the bin unless all power driven equipment has been shutdown and locked out.

Never enter the bin when the sweep is in operation.

All start and stop controls (electrical circuit box) must be installed outside the bin, Never on the inside of the bin. Be cautious of electrical hazards.

Keep work area clean and free from tools and objects that may cause accidental tripping or falling.

Some of the components are heavy. To avoid personal injury, use assistance when lifting these parts.

Electric motors and controls shall be installed by a qualified electrician and must meet the standards set by the National Electric Code and all local and state codes.

1. Mount the tractor gearbox to the main frame as shown in Fig. 21. Secure using four (4) 1/2" x 2" bolts and nylon locknuts.
2. Mount the electric motor to the top of the gearbox and secure using four (4) 3/8" x 1" bolts and lock washers (the bolts will screw into the bottom side of the motor, See Fig. 21).
3. Slide a wheel hub onto each of the shafts located on the sides of the gearbox. Secure each hub with one (1) 3/8" x 2 1/2" bolt and nylon locknut.

- The sweep tractor will attach to different shields depending on the number of sweep sections used. There are six prepunched holes in the shield that the tractor will bolt to.

Refer to the Sweep Flight Section illustrations on (Pages 26 to 32) for recommended tractor location. **IMPORTANT!** Before installing the tractor, check the location of the intermediate bin wells to ensure they are not in the direct path of the tractor as it travels around the bin.

If so, the tractor will have to be moved and new holes drilled in the shield for mounting the tractor. If the tractor does require being moved, try to keep it as close to its intended location as possible.

- If the sweep auger is being installed in a 60' to 120' dia. bin, the sweep tractor is provided with a weight kit for greater traction.
- Two 50 lb. (22.7 kg) weights have been supplied for 60' to 80' dia. bins, and four 50 lb. (22.7 kg) weights have been supplied for 88' to 120' dia. bins. This is the recommended amount of weight. Additional weight can be added if desired, though max. weight should not exceed 400 lbs. (181 kg).

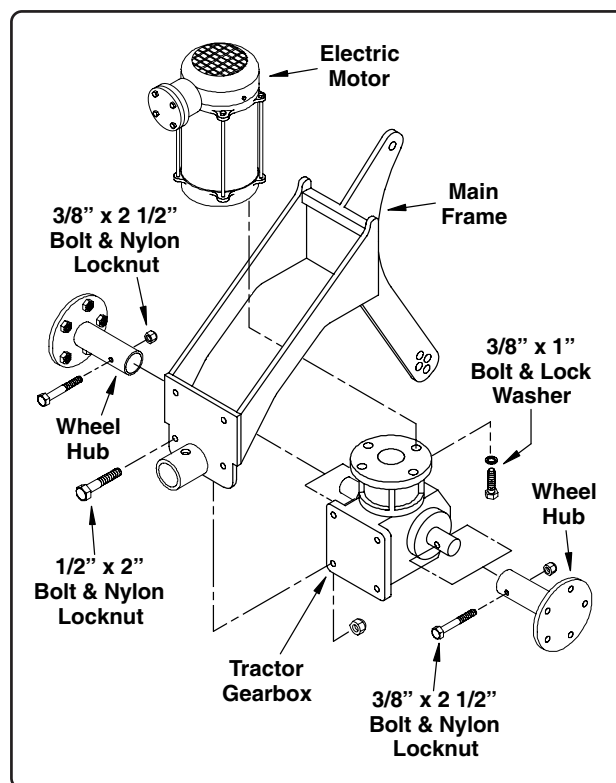

Fig. 21

ASSEMBLY INSTRUCTIONS

SWEEP TRACTOR ASSEMBLY (con't.)

4. Assemble the rubber disc, the retainer disc's and 3/8" thick spacer as shown below (one retainer disc, the rubber disc with 3/8" thick spacer and the second retainer disc).

Insert the spacer bushing for the main frame leg in the second lowest hole in leg and install a rubber disc assembly onto each side of the leg. Secure the disc assemblies to the main frame leg using one (1) 3/8" x 3" bolt and nylon locknut.

Note: There are four holes in the lower leg where the rubber disc assemblies mount, each hole indicating 1/2" increments.

The lower two holes will give the tractor more "digging" power, where as the two upper holes allow for better traction.

Grain consistencies vary ranging from heavier moist grain, to light dry grain. Some of the heavier grain may cause the sweep tractor to climb the grain instead of extracting it. Using the lower holes will give the tractor more digging capabilities and help alleviate the problem of climbing. If the tractor still tries to climb, install disc's in the bottom hole.

5. Mount the left and right side tire and wheel assemblies. Note the V-shaped tire tread, the "V" needs to be facing to the front of the unit as shown in the illustration below.

6. Install the sweep tractor attachment bracket to the front of the main frame and secure using one (1) 1/2" x 3 1/2" bolt and nylon locknut. **Note the angle of the square tube on front of the attachment bracket, the angle needs to be facing the right side as shown in the illustration below.**

7. Secure the shield attachment bracket to the front of the tractor assembly. Use one (1) 3/8" x 3 1/2" bolt, two (2) flat washers and one (1) nylon locknut on the upper slotted holes.

Use one (1) 3/8" x 3 1/2" bolt and nylon locknut on the lower holes.

Depending on which hole is used to mount the wheels (rubber disc assemblies) onto the main frame leg, it may be necessary to adjust the attachment bracket to keep the sweep section level. Pivot the bracket to the appropriate slot and secure into place.

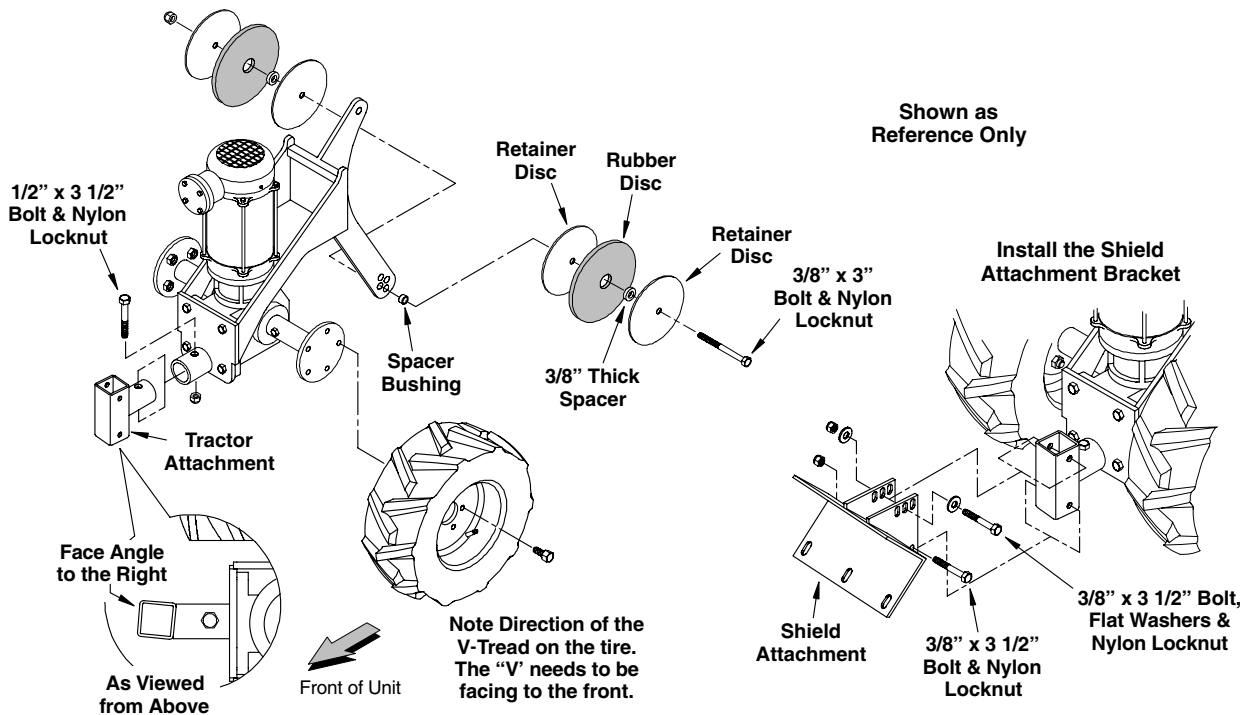

The shield attachment bracket can be adjusted to match the height and angle of the sweep assembly.

Use the adjustment holes as needed to help keep the sweep assembly aligned and level.

SWEEP TRACTOR ASSEMBLY (con't.)

8. Connect the electrical wiring to the tractor motor. The wiring may either be connected on a separate circuit so the tractor can be started and stopped independently (**recommended**) or it can be connected to the same circuit as the sweep motor, which would allow the tractor to turn on and off with the sweep auger.
Electric motors and controls shall be installed by a qualified electrician and must meet the standards set by the National Electric Code and all local and state codes.
9. Run the electrical wiring for the tractor over the top of the shield sections, to the cord holder attached to the drive motor assembly (make sure to support the cord to the shields so it cannot become entangled in the auger when the sweep is in operation).
10. Insert the cord thru the clamp on the lower ring of the cord holder and thru the upper ring of the holder. Route the cord to the power source making sure to keep it high enough so it cannot become entangled in the sweep as it travels around the bin.
Attach the cord above the doorway in the same manner as the electric cord from the drive motor was attached.
The start and stop controls (electrical circuit box) must be installed outside the bin, never on the inside. The controls do not have to be mounted onto the bin, but must be located so the operator has full view of the entire operation.
11. Make certain any excess length of cord is properly secured to the tractor and/or to the shields.

A typical installation (**recommended**) will use a single connection for the electric motor and a single connection for the tractor. This will allow the tractor to be started and stopped independently from the auger. The illustration shows this particular type of connection.

An alternate installation may use only one cord for both the tractor and electric motor. However, this would allow the tractor and auger to be started and shut down at the same time.

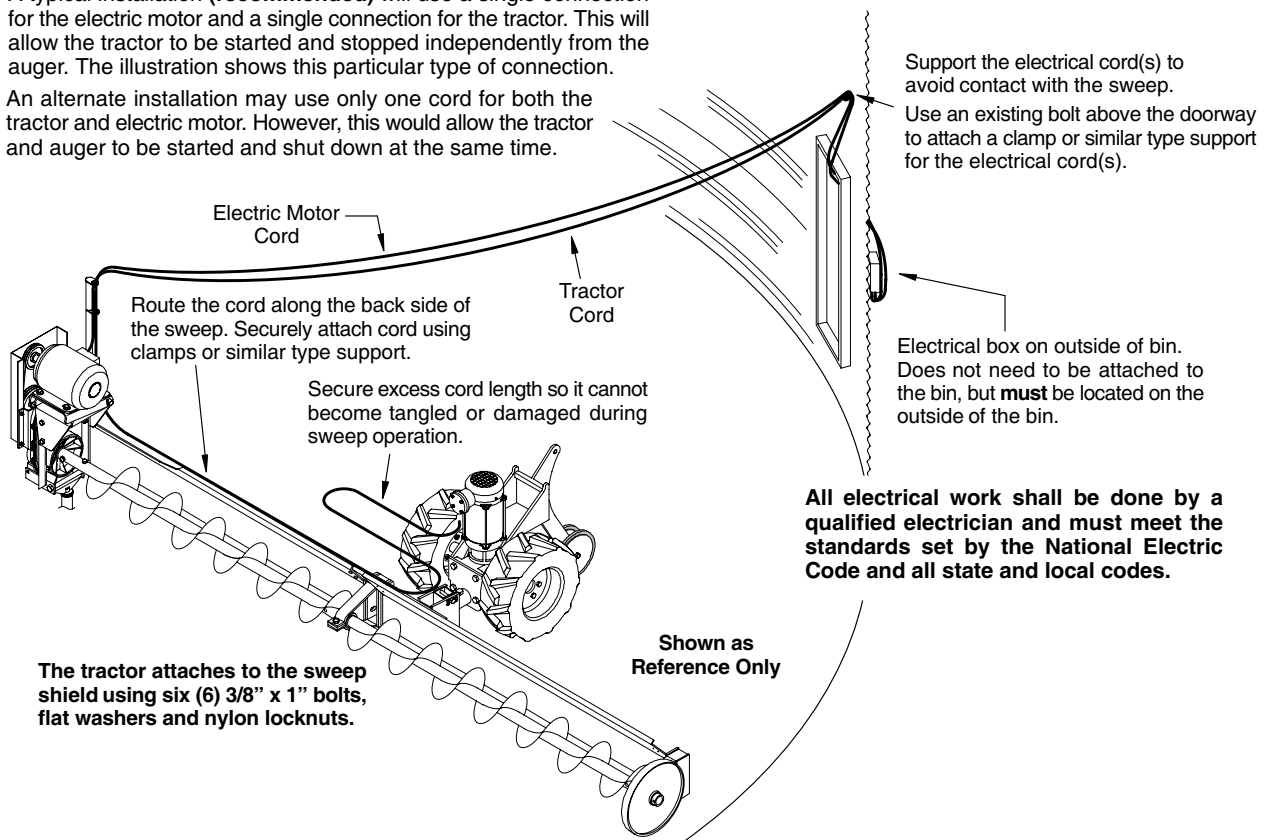

ASSEMBLY INSTRUCTIONS

SWEEP TRACTOR ASSEMBLY (con't.)

12. Hang the weights onto the upper portion of the main frame as shown in Fig. 22 (weights should be distributed equally on both sides of the support arm). Secure the weights using the weight retaining bolt, 3/4" flat washers and 3/4" nylon locknuts.

Two weights of 50 lbs. (23 kg) each are supplied for 60' to 80' diameter bins, and four weights have been supplied for 88' to 120' diameter bins. These are the recommended weights for bins of their respective size.

Additional weights can be added for a total of up to eight weights, however it is recommended not to exceed a total of 400 lbs (181 kg).

13. Check that all tools, materials or other objects are picked up and out of the bin. Ensure all sweep and tractor hardware is tight, and all electrical cords are properly supported and cannot become entangled during sweep operation.

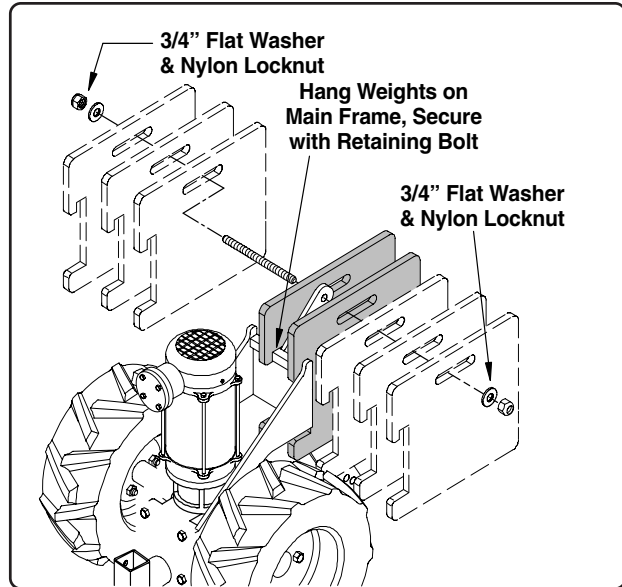

Fig. 22

SWEEP FLIGHT SECTION ASSEMBLIES

The following illustrations (Pages 26 to 32) show the distance the sweep tractor and carriers are from the bins center pivot point. These measurements should be used to help determine locations of the intermediate wells during bin erection (all measurements are approximate and taken from the bins center pivot point).

Make sure to locate the intermediate wells so they are not in the direct path of the tractor or carriers as they travel around the bin.

If the sweep is being installed in a bin that has existing intermediate wells, use the measurements to help determine the path of the tractor. If the wells are in the path, the tractor will need to be moved and new holes drilled for attaching the tractor to the shield (keep tractor as close to the original position as possible).

The carriers are installed between the flight sections and cannot be repositioned. Therefore, if the existing wells are in the path of the carrier, a thin metal plate (or similar item) should be placed over the well opening to allow the carrier to travel over it.

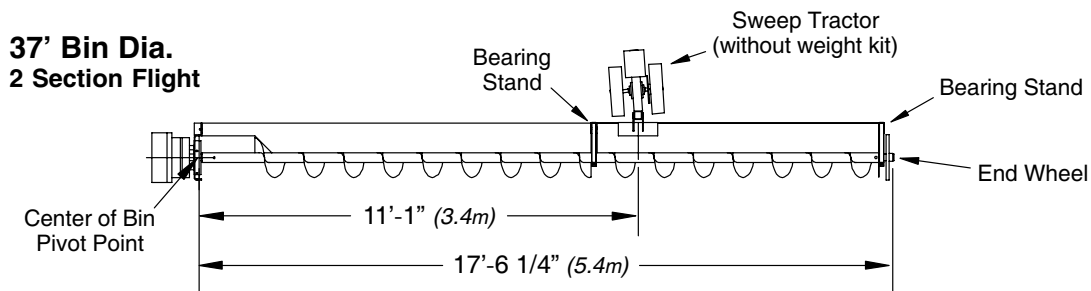
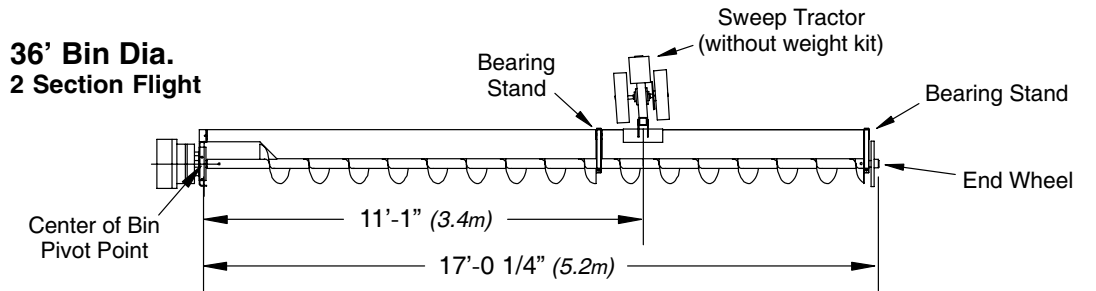

ASSEMBLY INSTRUCTIONS

SWEEP FLIGHT SECTION ASSEMBLIES (con't.)

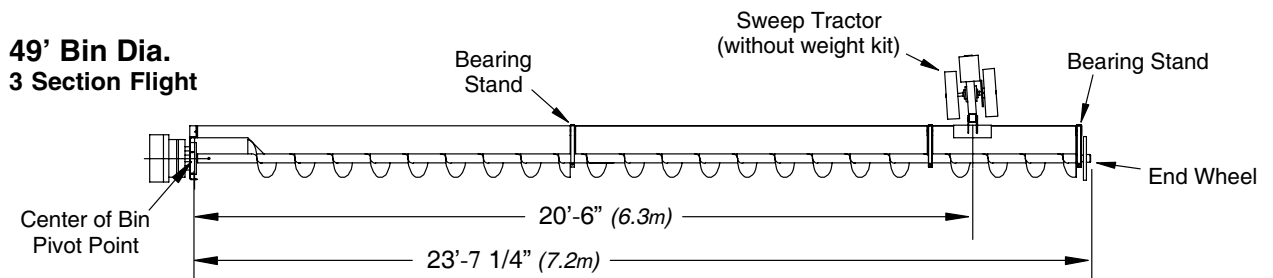
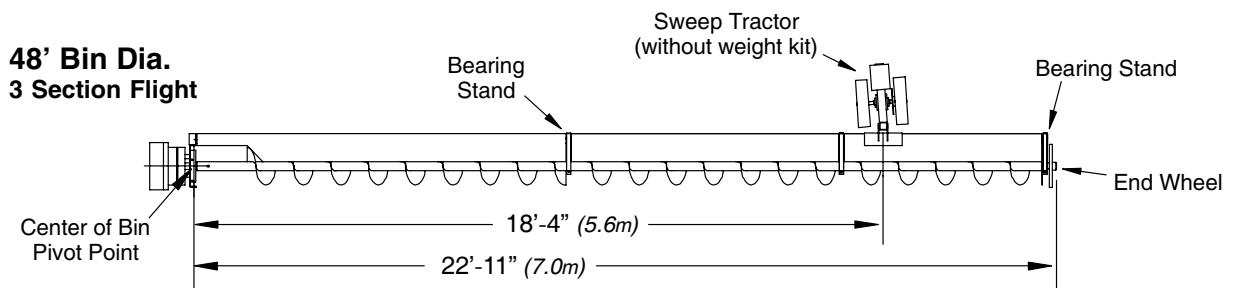
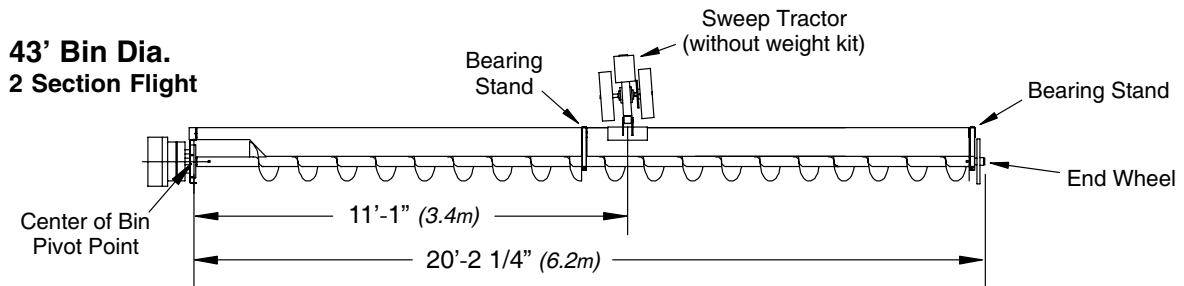
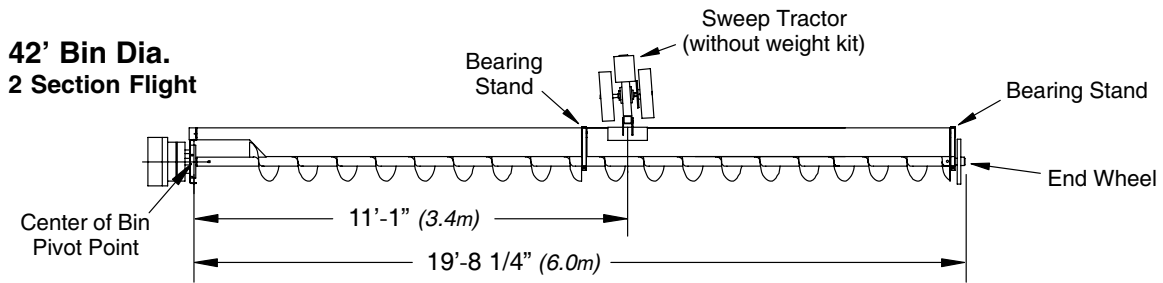
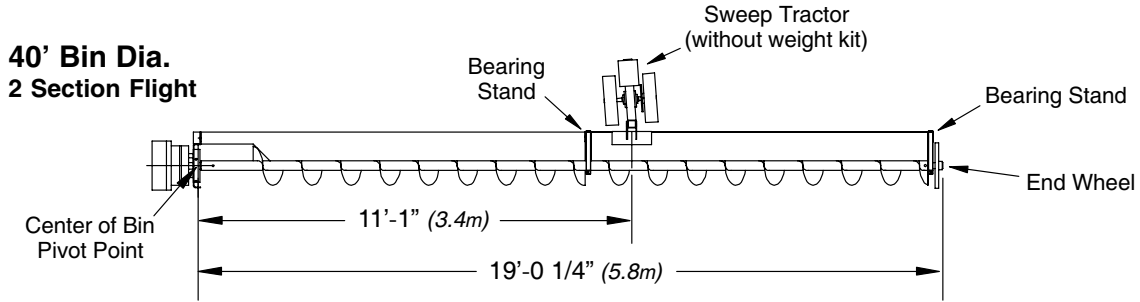

ASSEMBLY INSTRUCTIONS

SWEEP FLIGHT SECTION ASSEMBLIES (con't.)

54' Bin Dia. 3 Section Flight

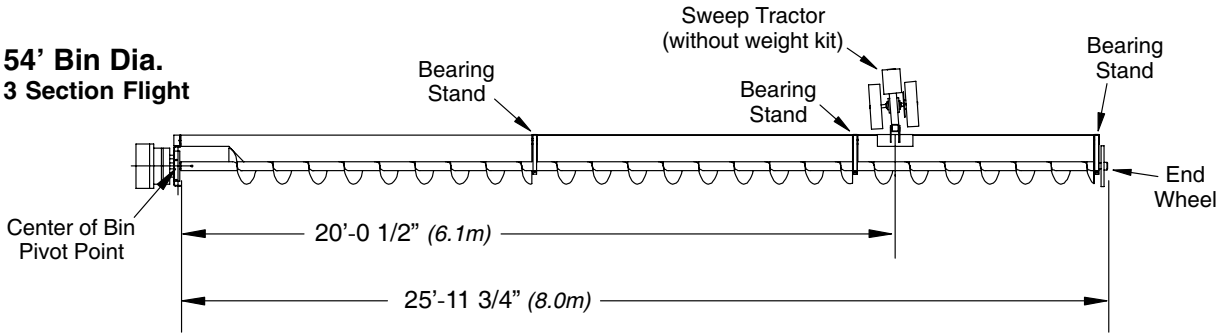

55' Bin Dia. 3 Section Flight

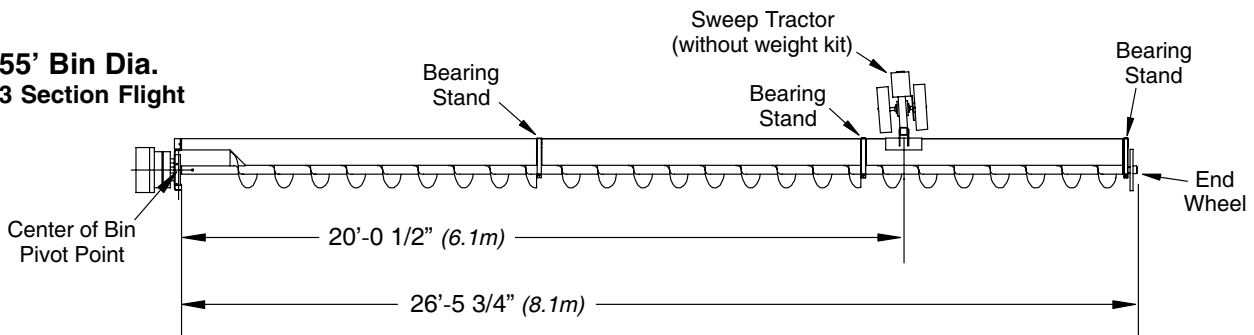

59' Bin Dia. 3 Section Flight

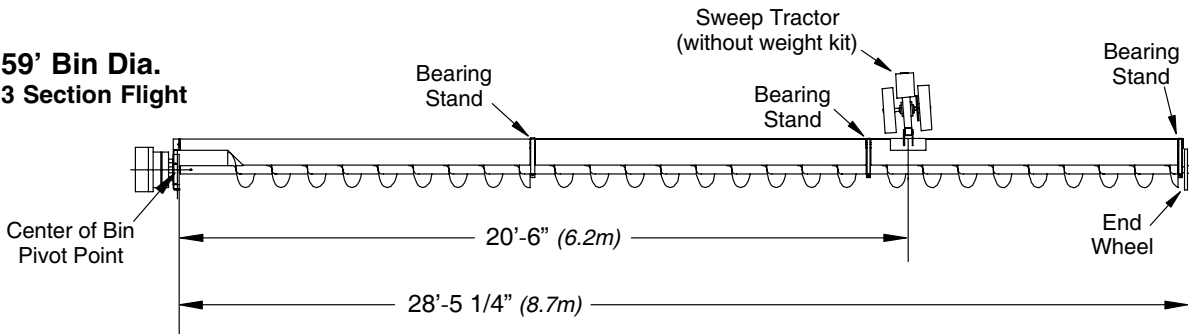

60' Bin Dia. 3 Section Flight

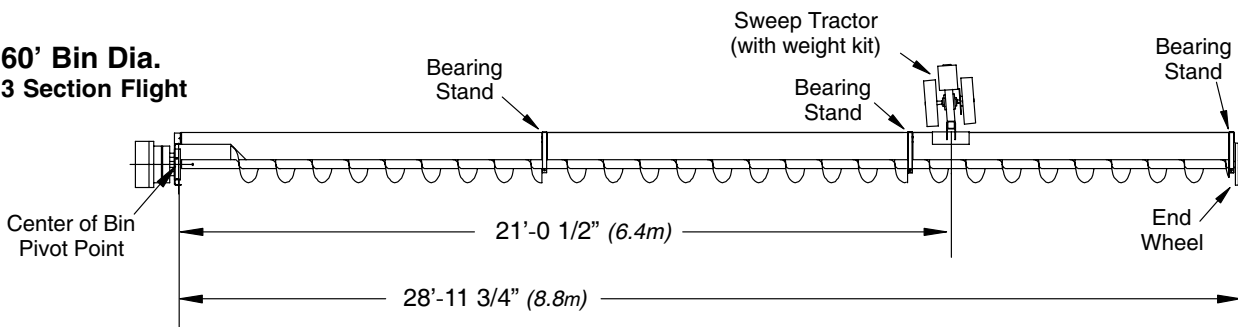

ASSEMBLY INSTRUCTIONS

SWEEP FLIGHT SECTION ASSEMBLIES (con't.)

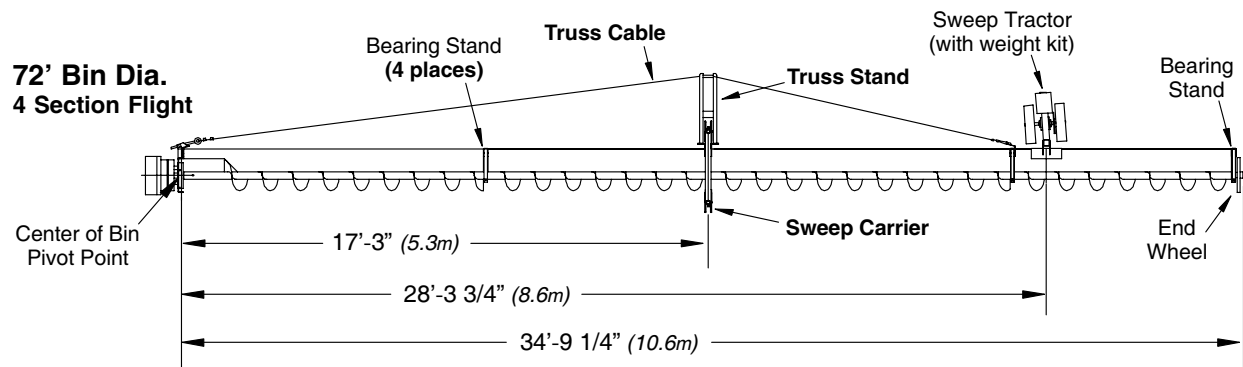
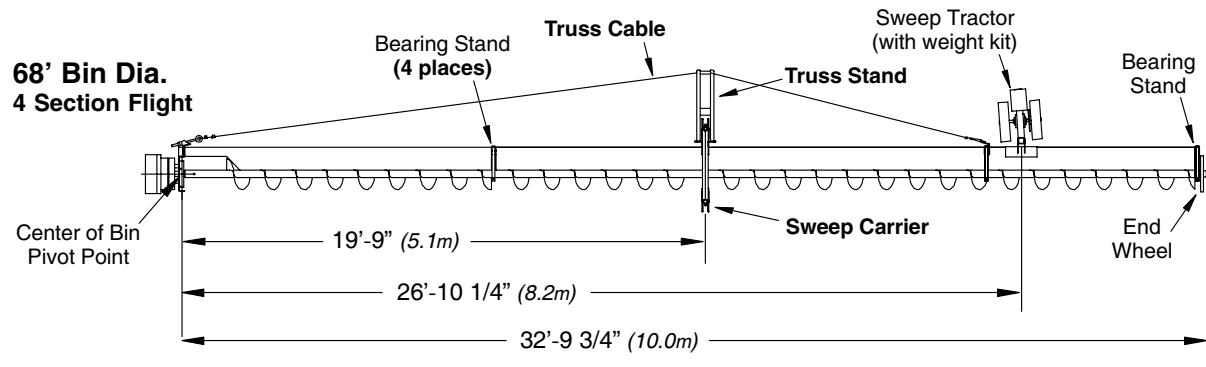
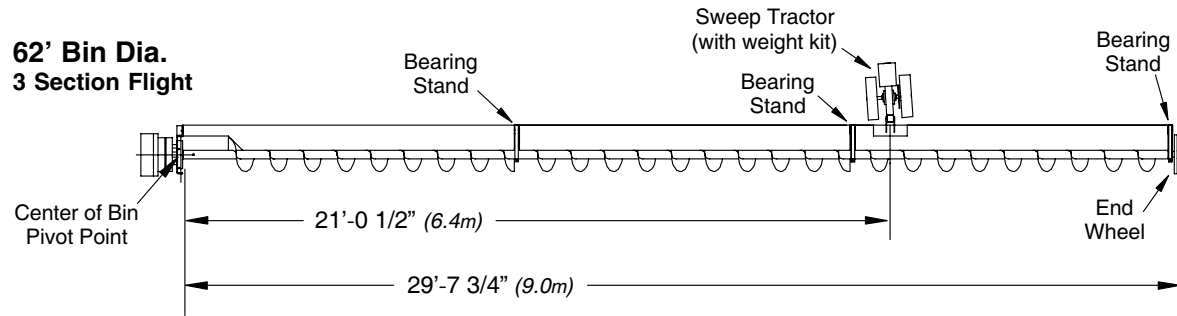

ASSEMBLY INSTRUCTIONS

SWEEP FLIGHT SECTION ASSEMBLIES (con't.)

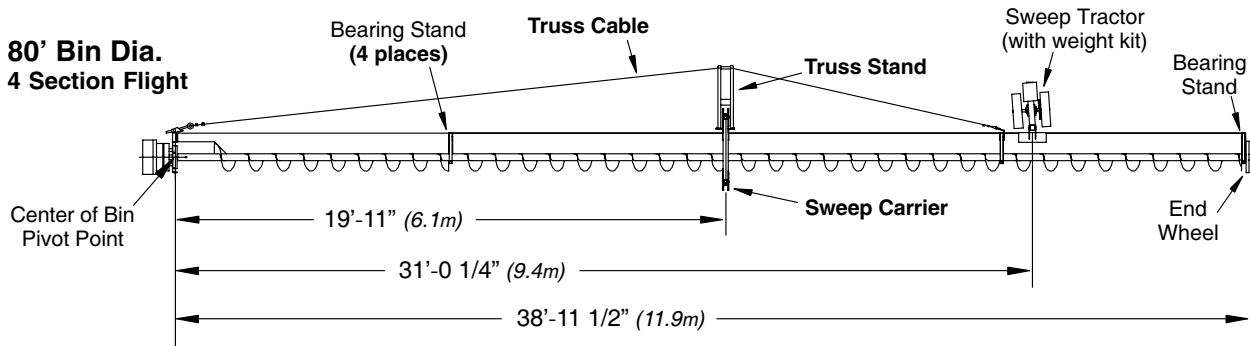
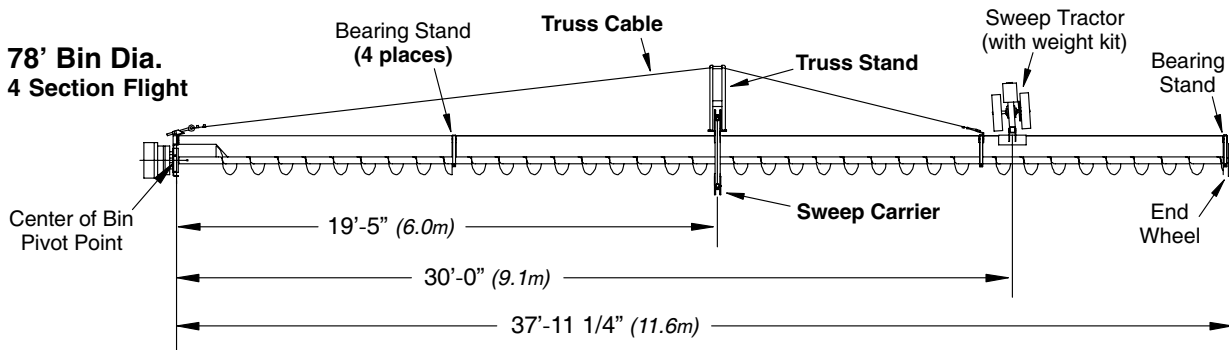
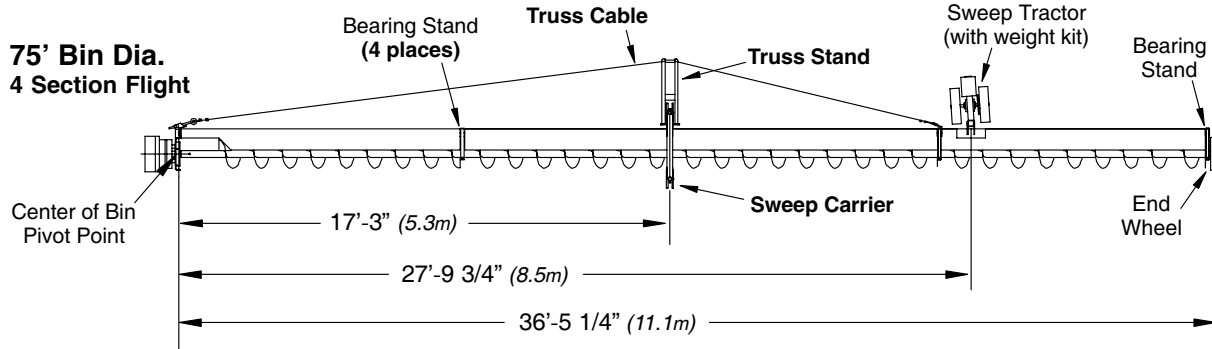

ASSEMBLY INSTRUCTIONS

SWEEP FLIGHT SECTION ASSEMBLIES (con't.)

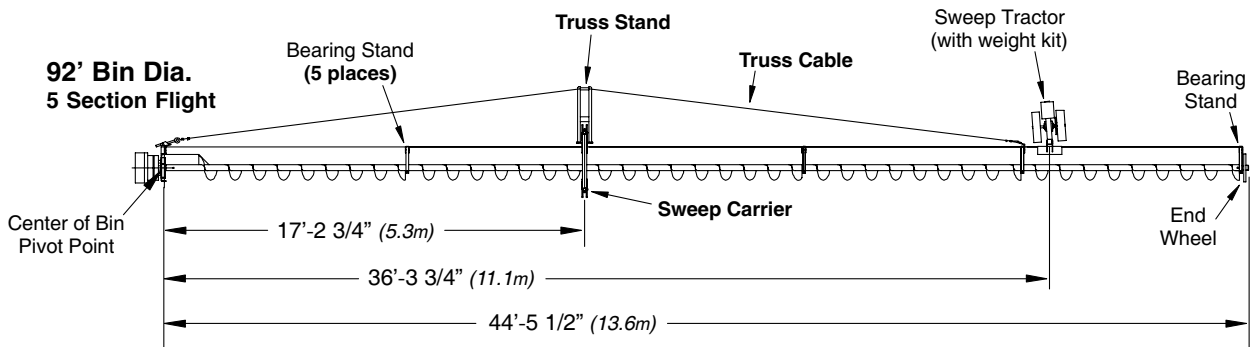
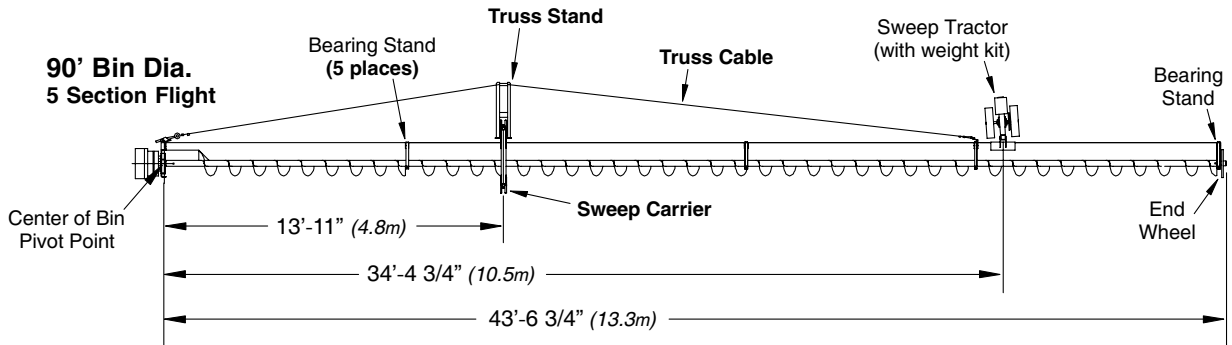
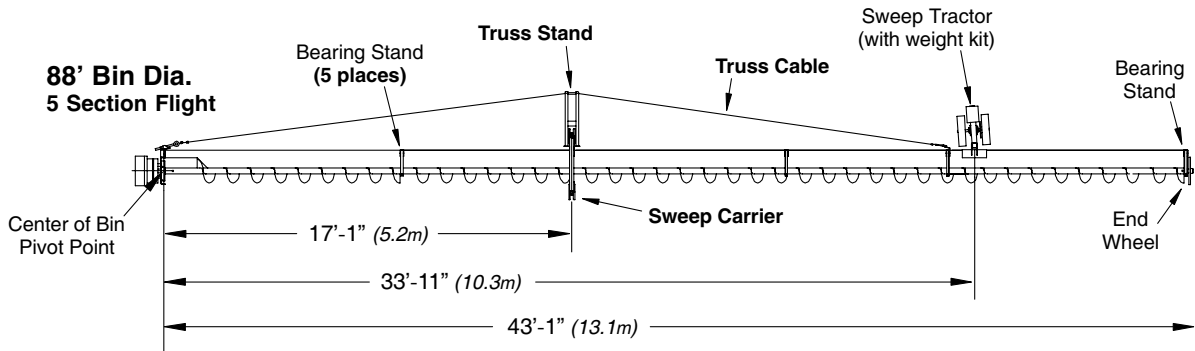

ASSEMBLY INSTRUCTIONS

SWEEP FLIGHT SECTION ASSEMBLIES (con't.)

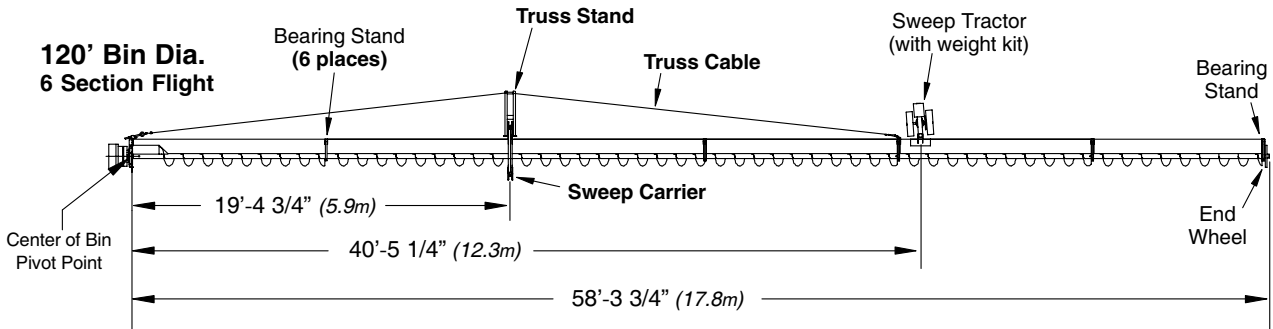
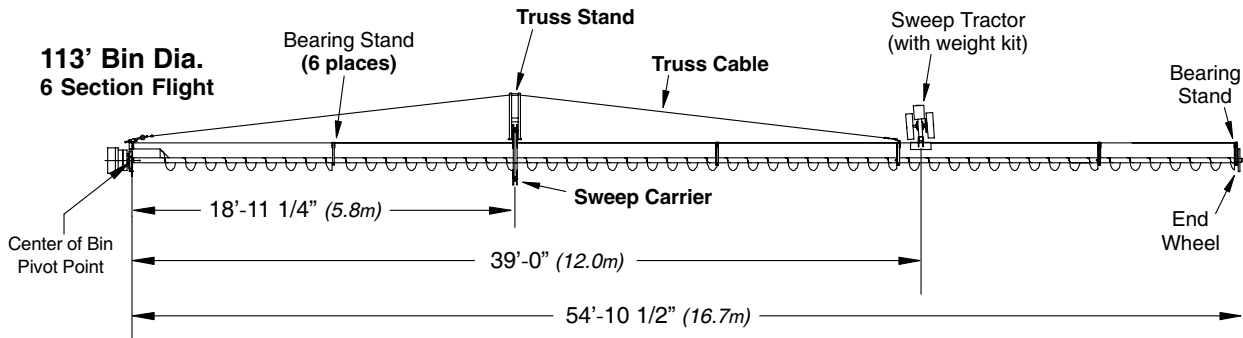
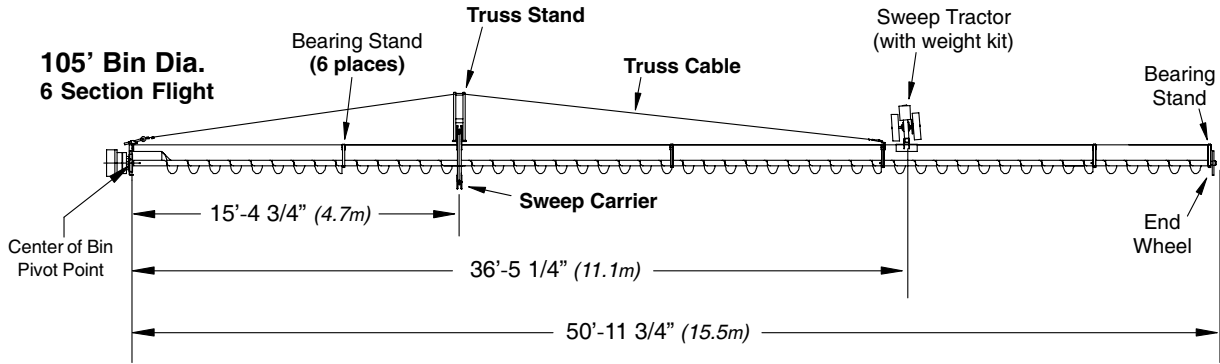

PARTS LIST TABLE OF CONTENT

Safety Decals P-1

3:1 Reducer, Drive Components P-2 to P-3

4:1 Reducer, Drive Components P-4 to P-5

3:1 Reducer (1011904) Parts Breakdown P-6

Sweep Carrier Components P-7

Sweep Flights and Shields f/ 2 & 3 Flight Sections (36' to 62' bin dia's.) P-8 to P-9

Sweep Flights and Shields f/ 4 to 6 Flight Sections (68' to 120' bin dia's.)... P-10 to P-11

Sweep Tractor Components P-12

SAFETY DECALS & SIGNS

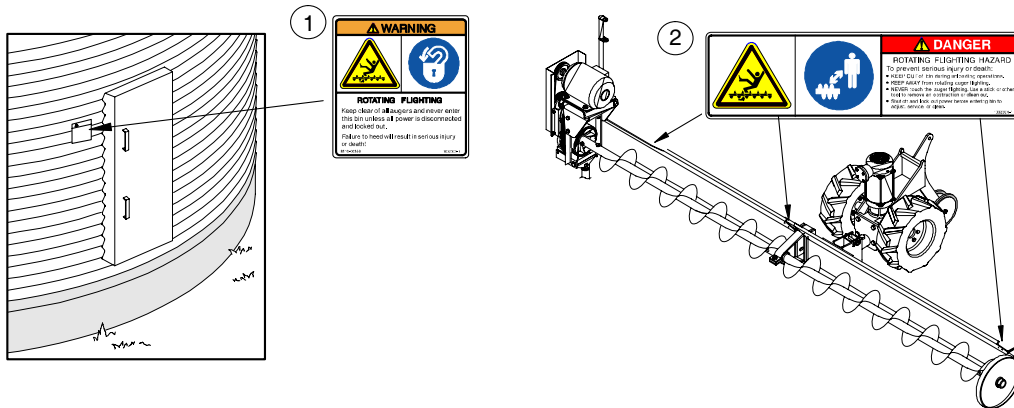

Ref. No.	Part No.	Description
1	1002303-1	Decal, Danger: Never Enter Bin...
2	1002304-1	Decal, Danger: Keep Out of Bin...

PARTS LIST

Page P-2

3:1 RATIO CHAIN DRIVE REDUCER
DRIVE COMPONENTS for
1214 SERIES COMMERCIAL KLEAN SWEEP
used in 36' to 78' Dia. Bins

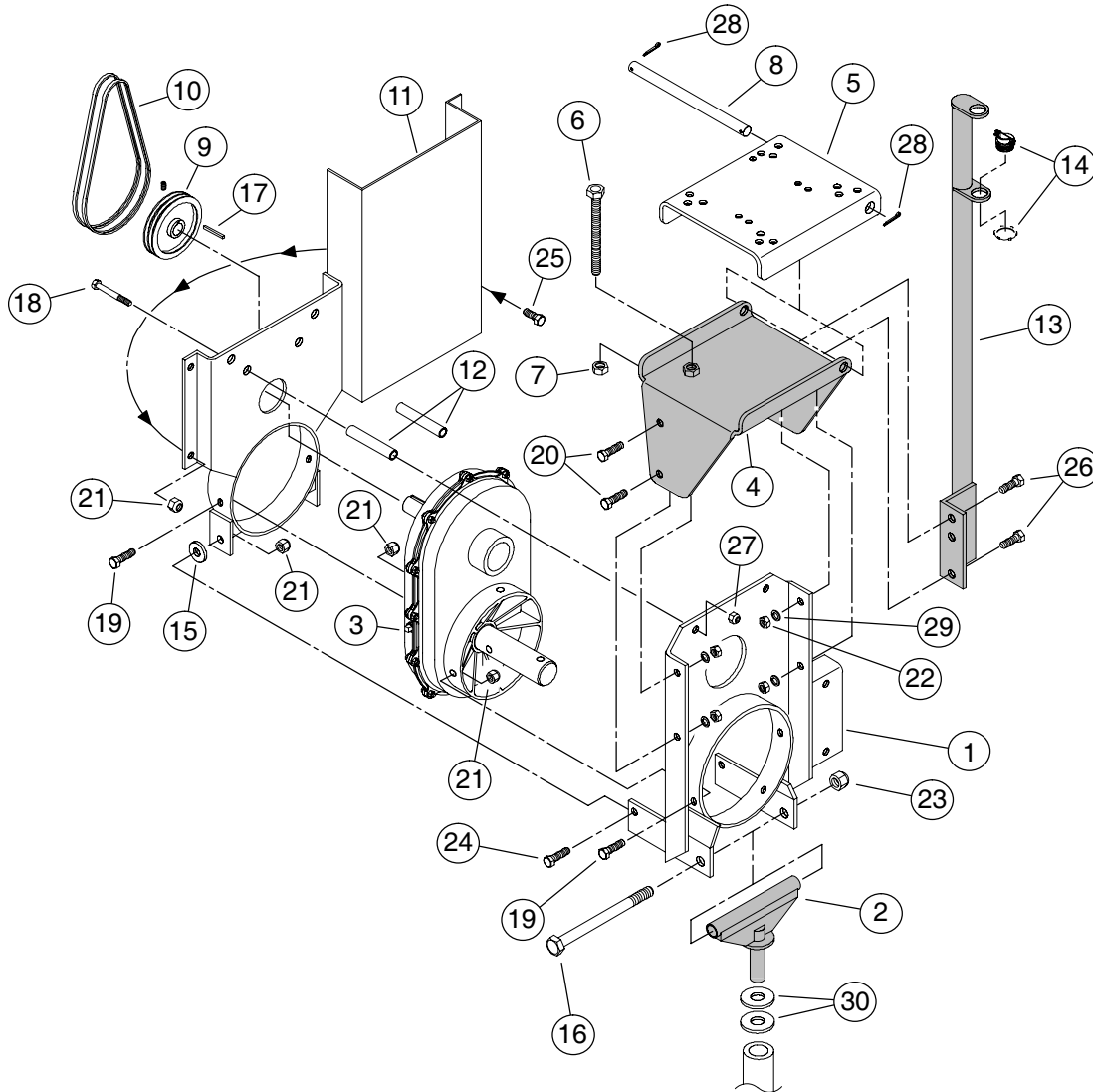

PARTS LIST

3:1 RATIO CHAIN DRIVE REDUCER
DRIVE COMPONENTS for
1214 SERIES COMMERCIAL KLEAN SWEEP
used in 36' to 78' Dia. Bins

Ref. No.	Part No.	Description	Ref. No.	Part No.	Description
1	1011903	Plate, Gearbox Mount	14	1006763	Cord Clamp f/ electrical cord
2	1011859	Center Pivot Weldment	15	1005442	Spacer, 1" O.D. x 1/4" thick
3	1011904	Reducer, 3:1 Ratio (chain drive)	16	835058	Pivot Bolt, 3/4-10 x 11" G5 PLT
4	1018802	Plate, Motor Mount Support	17	4046A1	Key, 1/4" x 3" f/ Input Shaft
5	1018758	Plate, Motor Mount	18	1002211	Bolt, 1/4-20 x 5" G5 PLT
6	1022381	Rod, Adjustment (3/4-10 thread)	19	33060	Bolt, 3/8-16 x 1" G5 PLT
7	D1152	Nut, 3/4-10 Non-Lock PLT	20	33082	Bolt, 1/2-13 x 1 1/4" G5 PLT
8	1018789	Pin, Pivot f/ Motor Mount Plate	21	33136	Nut, 3/8-16 Nylon Lock PLT
9	40152	Sheave, 12" O.D. 2 belt (f/ 36' to 37' dia. bins)	22	33138	Nut, 1/2-13 Non-Lock PLT
(9)	40154	Sheave, 12" O.D. 3 belt (f/ 40' to 78' dia. bins)	23	33140	Nut, 3/4-10 Nylon Lock PLT
10	40119	Belt, B-54	24	33229	Bolt, 3/8-16 x 1 1/4" G5 PLT
(10)	40120	Belt, B-57	25	33309	Bolt, 3/8-16 x 3/4" G5 PLT
11	1006757	Belt Guard w/ Mounting Ring	26	1002227	Bolt, 1/2-13 x 1 1/2" G5 PLT
12	1011901	Spacer, Belt Guard	27	1025584	Nut, 1/4-20 Lock PLT
13	1018804	Support, Cord Holder	28	3337A1	Pin, Cotter, 3/16" x 1 1/2"
			29	D1143	Washer, 1/2" Lock PLT
			30	D1160	Washer, 1" Flat PLT

PARTS LIST

Page P-4

4:1 RATIO GEAR DRIVE REDUCER
DRIVE COMPONENTS for
1214 SERIES COMMERCIAL KLEAN SWEEP
used in 80' to 120' Dia. Bins

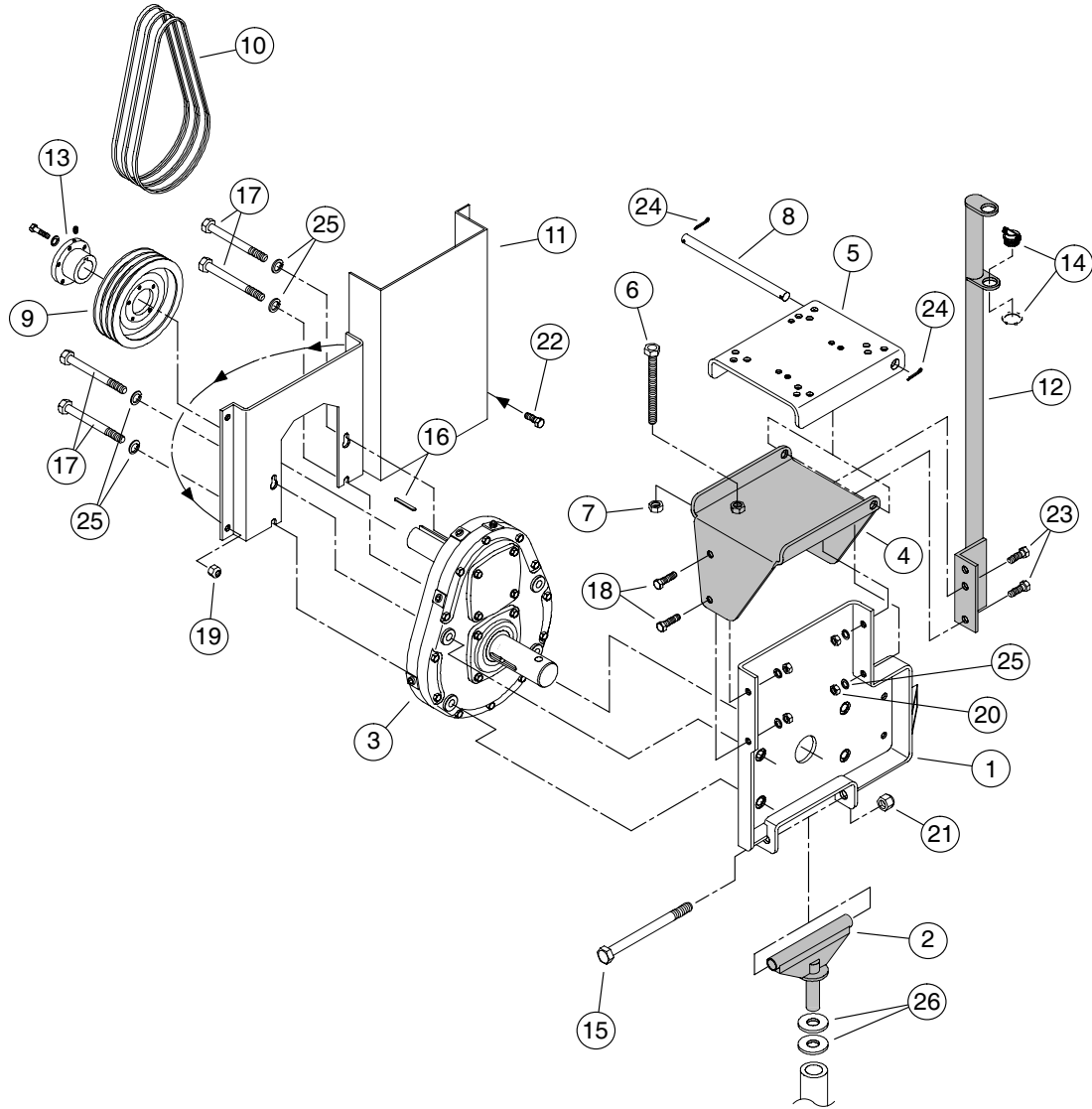

PARTS LIST

4:1 RATIO GEAR DRIVE REDUCER
DRIVE COMPONENTS for
1214 SERIES COMMERCIAL KLEAN SWEEP
used in 80' to 120' Dia. Bins

Ref. No.	Part No.	Description	Ref. No.	Part No.	Description
1	1029963	Plate, Gearbox Mount	14	1006763	Cord Clamp f/ electrical cord
2	1011859	Center Pivot Weldment	15	835058	Pivot Bolt, 3/4-10 x 11" G5 PLT
3	1025519-1	Reducer, 4:1 Ratio (gear drive)	16	4049A1	Key, 3/8" x 1 1/2" f/ Input Shaft
4	1031327	Plate, Motor Mount Support	17	4917	Bolt, 1/2-13 x 5" G5 PLT
5	1018758	Plate, Motor Mount	18	33082	Bolt, 1/2-13 x 1 1/4" G5 PLT
6	1022381	Rod, Adjustment (3/4-10 thread)	19	33136	Nut, 3/8-16 Nylon Lock PLT
7	D1152	Nut, 3/4-10 Non-Lock PLT	20	33138	Nut, 1/2-13 Non-Lock PLT
8	1018789	Pin, Pivot f/ Motor Mount Plate	21	33140	Nut, 3/4-10 Nylon Lock PLT
9	3271A1	Sheave, 11" P.D. 3 belt	22	33309	Bolt, 3/8-16 x 3/4" G5 PLT
10	40120	Belt, B-57	23	1002227	Bolt, 1/2-13 x 1 1/2" G5 PLT
(10)	1023004	Belt, B-59	24	3337A1	Pin, Cotter, 3/16" x 1 1/2"
11	1031332	Belt Guard	25	D1143	Washer, 1/2" Lock PLT
12	1018804	Support, Cord Holder	26	D1160	Washer, 1" Flat PLT
13	3295A1	Bushing, 1 1/2" bore QD SK			

PARTS LIST

3:1 RATIO CHAIN DRIVE REDUCER

Complete Reducer Gearbox
Order Part No. 1011904

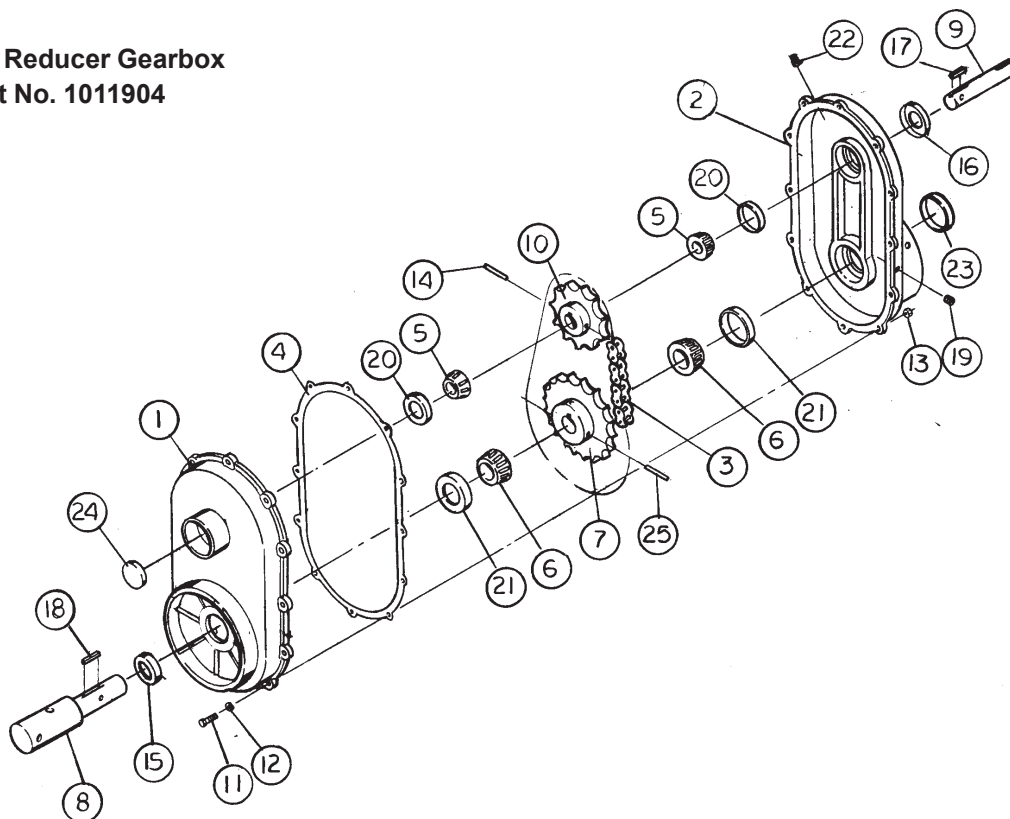

Ref. No.	Part No.	Description	Ref. No.	Part No.	Description
1	1001523	Aluminum Casting (inside)	14	33190	Roll Pin, 5/16" x 2 1/2"
2	1003044	Aluminum Casting (outside)	15	035860	Seal, Output Shaft
3	1001847	Chain, #80 roller, 36 pitch (with connecting link)	16	835168	Seal, Input Shaft
4	1001573	Gasket	17	4020A1	Key, 1/4" sq. x 1" long
5	106322	Cone Bearing, 1 1/4" bore (Timken No. 15123)	18	1002276	Key, 3/8" sq. x 1" long
6	035439	Cone Bearing, 1 1/2" bore (Timken No. LM29749)	19	458026	Plug, Drain 3/8" NPT
7	1001841	Sprocket, 27 tooth, 1 1/2" bore	20	106323	Bearing, Cup 1 1/4" (Timken No. 15245)
8	1011905	Stub, Output Shaft, 2" dia.	21	035440	Bearing, Cup 1 1/2" (Timken No. LM29710)
9	1001850	Stub, Input Shaft, 1 1/4" dia.	22	1001438	Plug, Vent, 3/8" NPT
10	1001840	Sprocket, 9 tooth, 1 1/4" bore	23	1001851	Cap
11	4757-1	Bolt, 5/15-18 x 1 1/4" G5 PLT	24	1001852	Cap
12	33144	Washer, 5/16" Lock PLT	25	33193	Roll Pin, 5/16" x 1 1/4"
13	33151	Nut, 5/16-18 Non-Lock PLT	26	1002275	Decal, "Fill with Oil" (not shown)

PARTS LIST

SWEEP CARRIER COMPONENTS

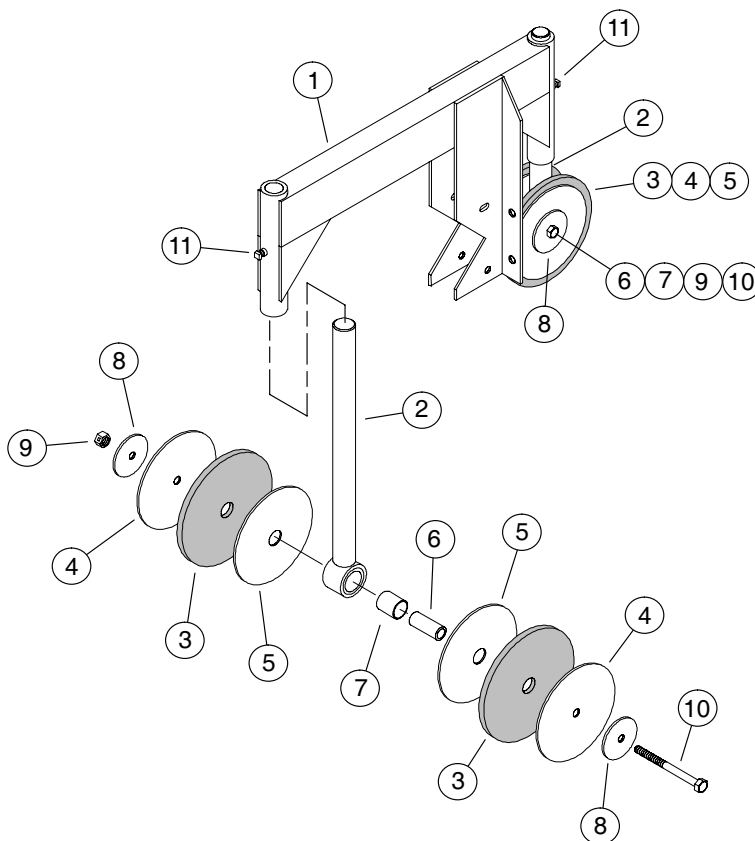

The spindle and wheels can also be ordered as a complete assembly. This assembly includes items 2 thru 10.
Order Part No. 1040916

Ref. No.	Part No.	Description	Ref. No.	Part No.	Description
1	1018724	Frame, Sweep Carrier	7	53924	Bushing f/ Sweep Carrier 1 1/4" O.D. x 1 5/8" long
2	1018731	Spindle, f/ Sweep Carrier	8	1040672	Washer, Retainer f/ Rubber Wheel
3	5305H	Rubber Disc f/ Carrier Wheel	9	1005127	Nut, 1/2-13 Side Depress Lock PLT
4	1040671	Retainer Disc (outer)	10	1002230	Bolt, 1/2-13 x 4" G5 PLT
5	1040670	Retainer Disc (inner)	11	33173	Setscrew, sq. hd 3/8" x 3/4"
6	1040915	Bushing, f/ Sweep Carrier 5/8" I.D. x 1" O.D. x 2 3/4" long			

PARTS LIST

Page P-8

SWEEP FLIGHTS & SWEEP SHIELD COMPONENTS **for UNITS WITH 2 & 3 FLIGHT SECTIONS** **(36' TO 62' Bin Dia's.)**

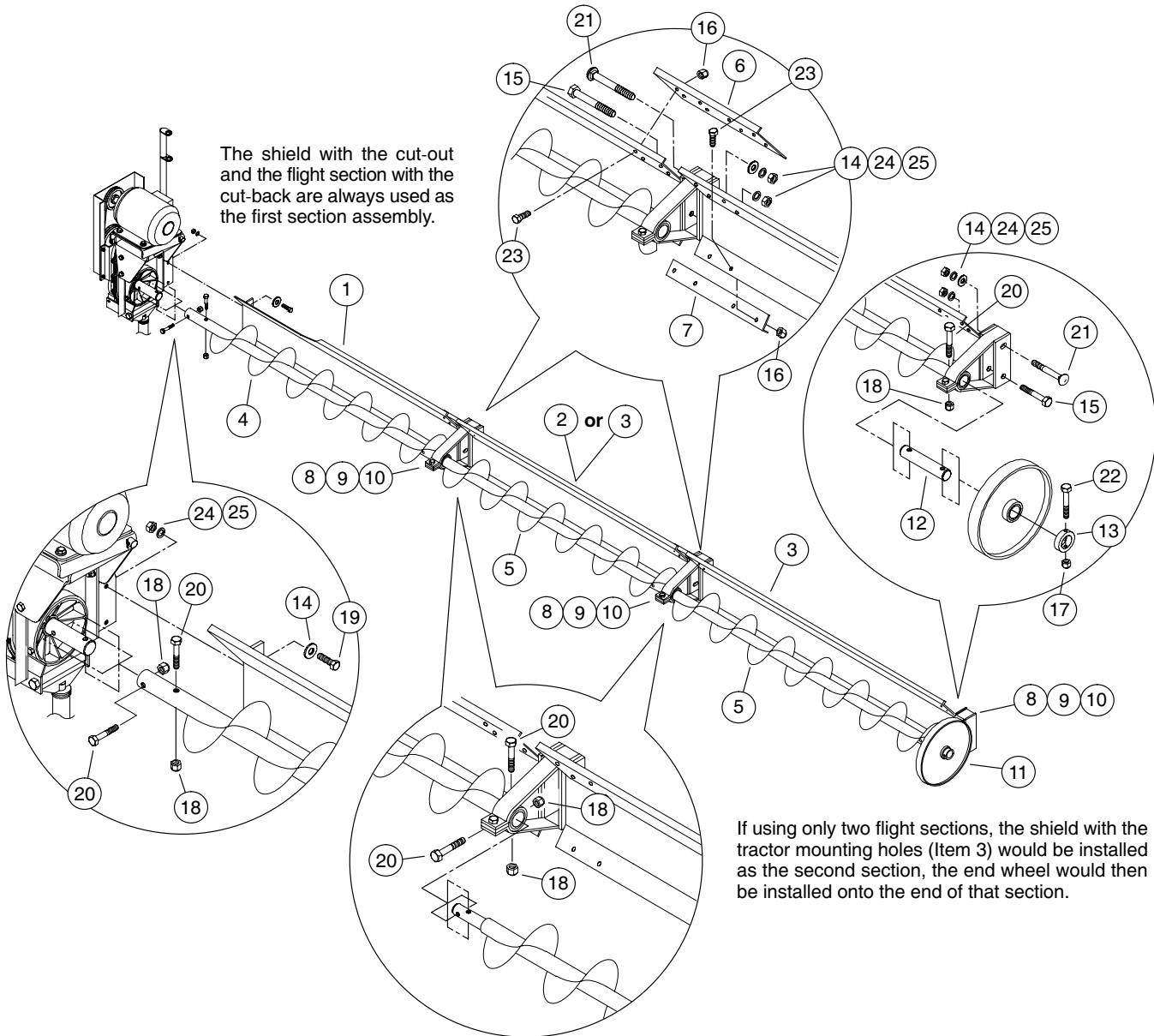

PARTS LIST

SWEEP FLIGHTS & SWEEP SHIELD COMPONENTS

for UNITS WITH 2 & 3 FLIGHT SECTIONS

(36' TO 62' Bin Dia's.)

Ref. No.	Part No.	Description	Ref. No.	Part No.	Description
1	1011885	Sweep, Back Shield w/ Cutout (9'-9 3/4" long, f/ 36' to 62' bin dia's.)	(5)	1011948	Flight Section, 5'-3 1/2" long
2	1011932	Sweep Back Shield, Solid Back (6'-7 1/2" long)	(5)	1011949	Flight Section, 6'-7 1/2" long
(2)	1011933	Sweep Back Shield, Solid Back (7'-1 1/2" long)	(5)	1011950	Flight Section, 7'-7 1/2" long
(2)	1011934	Sweep Back Shield, Solid Back (8'-7 1/2" long)	(5)	1011951	Flight Section, 8'-7 1/2" long
(2)	1011935	Sweep Back Shield, Solid Back (8'-10" long)	(5)	1011952	Flight Section, 8'-10" long
(2)	1011936	Sweep Back Shield, Solid Back (9'-3 1/2" long)	(5)	1011953	Flight Section, 9'-3 1/2" long
(2)	1011875	Sweep Back Shield, Solid Back (9'-9 3/4" long)	(5)	1011880	Flight Section, 9'-9 3/4" long
3	1018837	Sweep Back Shield w/ Tractor Mounting Holes (3'-9 1/2" long)	6	1011861	Splice Plate, Upper Shield
(3)	1018836	Sweep Back Shield w/ Tractor Mounting Holes (5'-3 1/2" long)	7	1011862	Splice Plate, Lower Shield
(3)	1018831	Sweep Back Shield w/ Tractor Mounting Holes (6'-7 1/2" long)	8	1012349	Bearing Stand, Standard
(3)	1018832	Sweep Back Shield w/ Tractor Mounting Holes (7'-1 1/2" long)	9	1011869	Bearing Holder w/ 2" I.D. Bronze Bearing
(3)	1018833	Sweep Back Shield w/ Tractor Mounting Holes (8'-7 1/2" long)	10	1254D	•Bronze Bearing (2" I.D.)
(3)	1018834	Sweep Back Shield w/ Tractor Mounting Holes (9'-3 1/2" long)	11	1016927	End Wheel
4	1011879	Flight Section w/ Cutback (9'-9 3/4" long, f/ all bin diameters)	12	1016920	Stub, End Wheel
5	1011947	Flight Section, 3'-9 1/2" long	13	1016921	Collar, End Wheel
			14	33024	Washer, 3/8" Flat PLT
			15	33068	Bolt, 3/8-16 x 3" G5 PLT
			16	33135	Nut, 5/16-18 Nylon Lock PLT
			17	33138	Nut, 1/2-13 Nylon Lock PLT
			18	33139	Nut, 5/8-11 Nylon Lock PLT
			19	33229	Bolt, 3/8-16 x 1 1/4" G5 PLT
			20	1002204	Bolt, 5/8-11 x 4" G5 PLT
			21	1002249	Bolt, Carriage 3/8-16 x 3" G5 PLT
			22	1007473	Bolt, 1/2-13 x 3 1/4" G5 PLT
			23	4701-1	Bolt, 5/16-18 x 3/4" G5 PLT
			24	D1149	Nut, 3/8-16 Non-lock PLT
			25	D1150	Washer, 3/8" Lock PLT

•Indented Parts Names Indicate these Parts are Included in the Previous Assembly.

PARTS LIST

SWEEP FLIGHTS & SWEEP SHIELD COMPONENTS **for UNITS WITH 4 to 6 FLIGHT SECTIONS** **(68' TO 120' Bin Dia's.)**

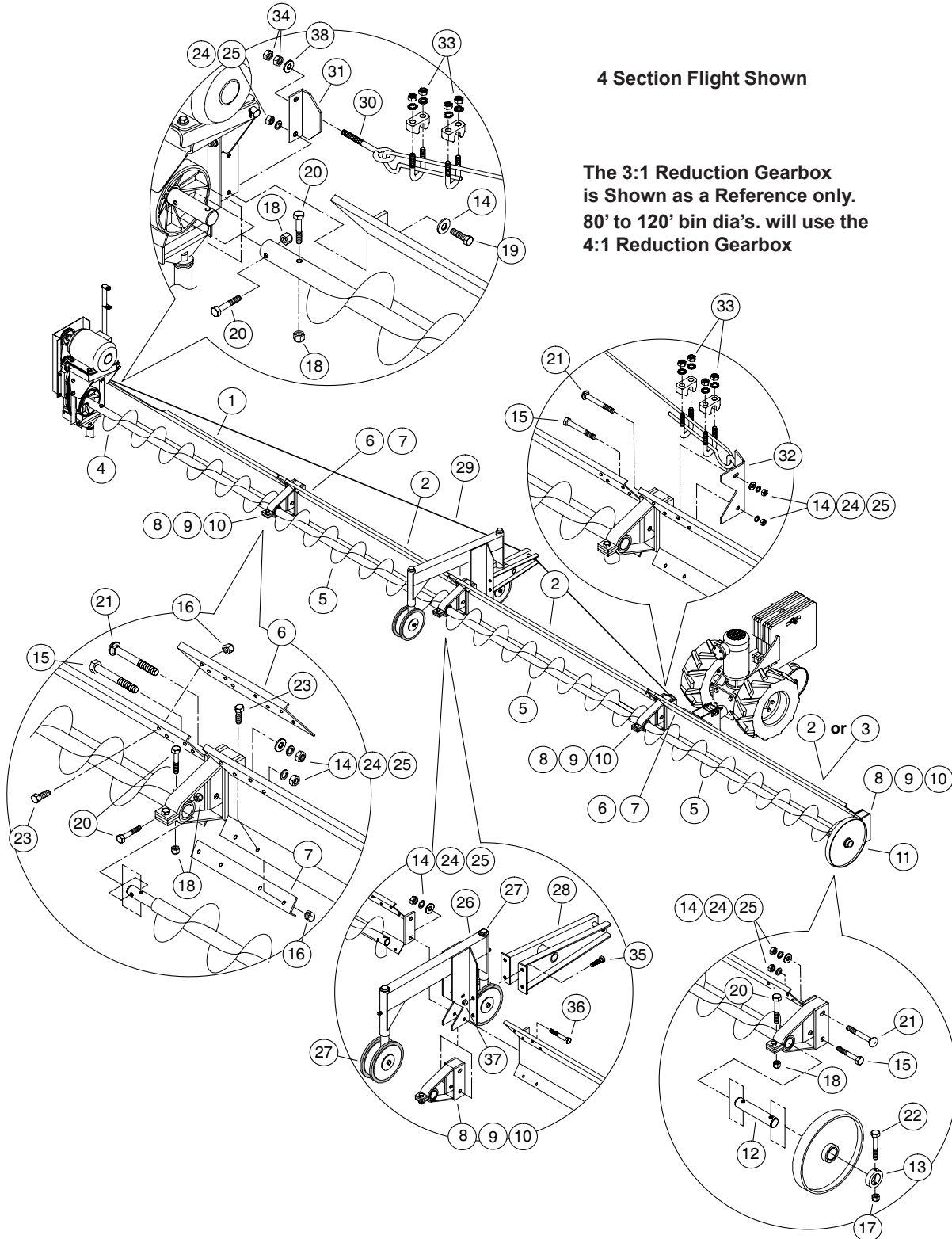

4 Section Flight Shown

The 3:1 Reduction Gearbox
is Shown as a Reference only.
80' to 120' bin dia's. will use the
4:1 Reduction Gearbox

PARTS LIST

SWEEP FLIGHTS & SWEEP SHIELD COMPONENTS

for UNITS WITH 4 to 6 FLIGHT SECTIONS

(68' TO 120' Bin Dia's.)

Ref. No.	Part No.	Description	Ref. No.	Part No.	Description
1	1011885	Sweep, Back Shield w/ Cutout (9'-9 3/4" long, f/ 36' to 78' bin dia's.)	6	1011861	Splice Plate, Upper Shield
(1)	1033884	Sweep, Back Shield w/ Cutout (9'-9 7/8" long, f/ 80' to 120' bin dia's.)	7	1011862	Splice Plate, Lower Shield
2	1011930	Sweep Back Shield, Solid Back (3'-9 1/2" long)	8	1012349	Bearing Stand, Standard
(2)	1011931	Sweep Back Shield, Solid Back (5'-3 1/2" long)	9	1011869	Bearing Holder w/ 2" I.D. Bronze Bearing
(2)	1011932	Sweep Back Shield, Solid Back (6'-7 1/2" long)	10	1254D	•Bronze Bearing (2" I.D.)
(2)	1011933	Sweep Back Shield, Solid Back (7'-1 1/2" long)	11	1016927	End Wheel
(2)	1011934	Sweep Back Shield, Solid Back (8'-7 1/2" long)	12	1016920	Stub, End Wheel
(2)	1011935	Sweep Back Shield, Solid Back (8'-10" long)	13	1016921	Collar, End Wheel
(2)	1011936	Sweep Back Shield, Solid Back (9'-3 1/2" long)	14	33024	Washer, 3/8" Flat PLT
(2)	1011875	Sweep Back Shield, Solid Back (9'-9 3/4" long)	15	33068	Bolt, 3/8-16 x 3" G5 PLT
3	1018837	Sweep Back Shield w/ Tractor Mounting Holes (3'-9 1/2" long)	16	33135	Nut, 5/16-18 Nylon Lock PLT
(3)	1018836	Sweep Back Shield w/ Tractor Mounting Holes (5'-3 1/2" long)	17	33138	Nut, 1/2-13 Nylon Lock PLT
(3)	1018831	Sweep Back Shield w/ Tractor Mounting Holes (6'-7 1/2" long)	18	33139	Nut, 5/8-11 Nylon Lock PLT
(3)	1018832	Sweep Back Shield w/ Tractor Mounting Holes (7'-1 1/2" long)	19	33229	Bolt, 3/8-16 x 1 1/4" G5 PLT
(3)	1018833	Sweep Back Shield w/ Tractor Mounting Holes (8'-7 1/2" long)	20	1002204	Bolt, 5/8-11 x 4" G5 PLT
(3)	1018838	Sweep Back Shield w/ Tractor Mounting Holes (8'-10" long)	21	1002249	Bolt, Carriage 3/8-16 x 3" G5 PLT
(3)	1018834	Sweep Back Shield w/ Tractor Mounting Holes (9'-3 1/2" long)	22	1007473	Bolt, 1/2-13 x 3 1/4" G5 PLT
(3)	1018835	Sweep Back Shield w/ Tractor Mounting Holes (9'-9 3/4" long)	23	4701-1	Bolt, 5/16-18 x 3/4" G5 PLT
4	1011879	Flight Section w/ Cutback (9'-9 3/4" long, f/ all bin diameters)	24	D1149	Nut, 3/8-16 Non-lock PLT
5	1011947	Flight Section, 3'-9 1/2" long	25	D1150	Washer, 3/8" Lock PLT
(5)	1011948	Flight Section, 5'-3 1/2" long	26	1018811	Sweep Carrier (See Page P-13)
(5)	1011949	Flight Section, 6'-7 1/2" long	27	1040916	Spindle Assembly f/ Carrier (See Page P-13 for Parts List)
(5)	1011950	Flight Section, 7'-7 1/2" long	28	1018733	Truss Stand
(5)	1011951	Flight Section, 8'-7 1/2" long	29	862066	Truss Cable, 5/16" x 34'-6" (f/ 4 section units)
(5)	1011952	Flight Section, 8'-10" long	(29)	1007896	Truss Cable, 5/16" x 43' (f/ 5 section units)
(5)	1011953	Flight Section, 9'-3 1/2" long	(29)	1011324	Truss cable, 5/16" x 41'-6" (f/ 6 section units)
(5)	1011880	Flight Section, 9'-9 3/4" long	30	866015-1	Eyebolt, 5/8-10 x 11"
			31	1012361	Bracket, Cable Anchor (3:1 units only)
			32	1018743	Cable Anchor
			33	3153A91	Clamp, 5/16" Cable
			34	D1170	Nut, 5/8-10 Non-Lock PLT
			35	33060	Bolt, 3/8-16 x 1" G5 PLT
			36	4827	Bolt, 3/8-16 x 3 1/2" G5 PLT
			37	33136	Nut, 3/8-16 Nylon Lock PLT
			38	33026	Washer, 5/8" Flat

• Indented Parts Names Indicate these Parts are Included in the Previous Assembly.

PARTS LIST

SWEEP TRACTOR COMPONENTS

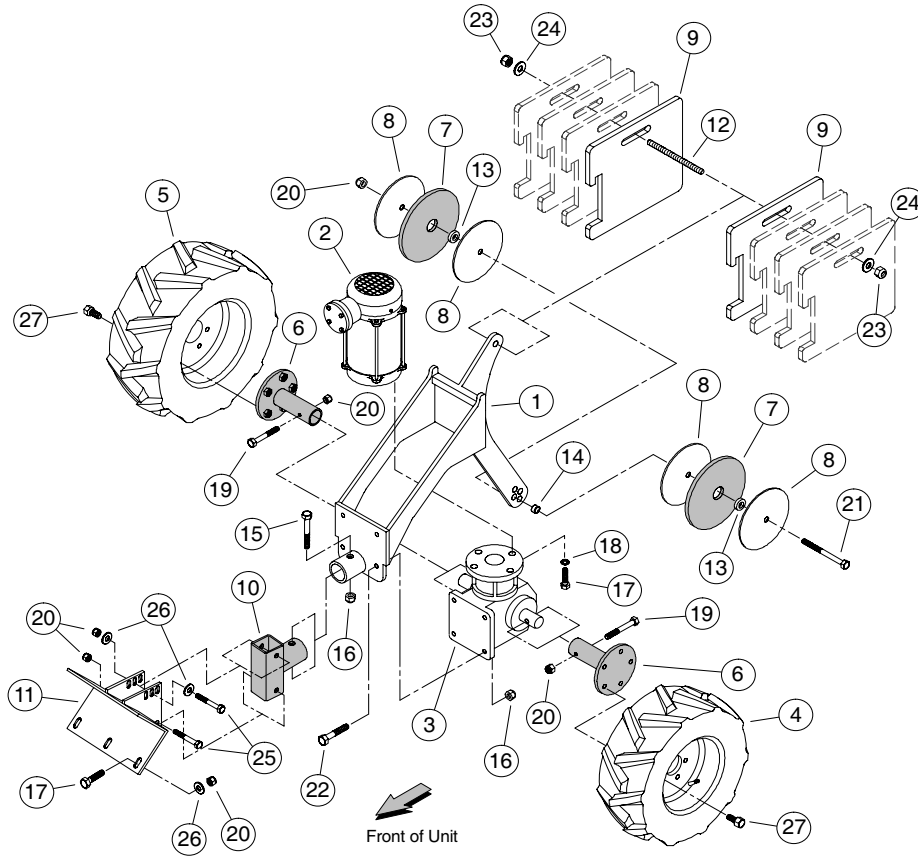

Ref. No.	Part No.	Description	Ref. No.	Part No.	Description
1	1026665	Frame, Sweep Tractor Main	12	1026662	Bolt, Weight Retaining
2	1026654	Motor, Electric, 1.5 hp 230/460 v, 60hz exp. proof	13	1040936	Spacer, 3/8" thick
(2)	1027063	Motor, Electric, 1.5 hp 230/460 v, 50hz exp. proof	14	1022801	Spacer Bushing f/ Wheels
(2)	1027064	Motor, Electric, 1.5 hp 230/460 v, 60hz	15	4911	Bolt, 1/2-13 x 3 1/2" G5 PLT
3	1026652	Gearbox, 240:1 Reduction	16	1011182	Nut, 1/2-13 Nylon Lock PLT
4	1026653	Wheel & Tire, 20 x 8 4-ply (RH)	17	33060	Bolt, 3/8-16 x 1" G5 PLT
5	1026676	Wheel & Tire, 20 x 8 4-ply (LH)	18	D1150	Washer, 3/8" Lock PLT
6	1026633	Hub, Wheel	19	33375	Bolt, 3/8-16 x 2 1/2" G5 PLT
7	5305H	Rubber Disc f/ Wheel	20	33136	Nut, 3/8-16 Nylon Lock PLT
8	1040935	Retainer Disc f/ Wheel	21	33068	Bolt, 3/8-16 x 3" G5 PLT
9	1022554-1	Weight, 50 lbs. (23 kg)	22	1002228	Bolt, 1/2-13 x 2" G5 PLT
10	1026693	Attachment, Sweep Tractor	23	D1152	Nut, 3/4-10 Nylon Lock PLT
11	1016928	Attachment, Tractor to Shield	24	33027	Washer, 3/4" Flat PLT
			25	33068	Bolt, 3/8-16 x 1" G5 PLT
			26	33024	Washer, 3/8" Flat PLT
			27	106241	Bolt, Wheel Lug

The 50 lb. weights (Item No. 9) are also available with a hot-dipped galvanized finish. Order Part No. 1022554-GALV-1

WARRANTY

W-1

AG GROWTH INTERNATIONAL INC. – FORM OF LIMITED WARRANTY

Ag Growth International Inc. (“AGI”) warrants that the goods and/or services being supplied (the “Goods”) will be free from defects in materials and workmanship under normal conditions, use, service, and maintenance, for a period of twelve (12) months from the date of first operation of the Goods, but in no event more than eighteen (18) months from the date of delivery of the Goods to the end-user (the “Warranty Term”). If the Goods are being used for rental purposes, the Warranty Term for the subject Goods shall be limited to 90 days.

Subject to AGI’s sole discretion, if the Goods, or a component thereof, are found to have a default in materials and/or workmanship within the Warranty Term, AGI will, at its own option and expense, repair or replace the subject Goods or refund the purchase price for the applicable Goods. Any warranty related expenses incurred on behalf of or by the end-user without the prior written consent of AGI shall be the sole responsibility of the end-user. Expenses relating to travel, customs or import duties and tariffs, equipment rental, and any costs associated with accessing the Goods are the sole responsibility of the customer. Warranty shall be void in the event the Goods are returned or disposed of without the written consent of AGI.

The customer shall not assert a claim that the Goods are defective unless the customer gives written notice to AGI of such defect within forty-eight (48) hours of discovering such defect. In the event of a warranty claim, the customer must complete any and all information required by AGI in order to properly assess or investigate the claim. AGI shall be given a reasonable opportunity to inspect and test the Goods in question. Failure by the customer to notify AGI of such claim within 48 hours shall operate as a waiver of any and all such claims by the customer.

THIS IS THE SOLE AND EXCLUSIVE WARRANTY GIVEN BY AGI WITH RESPECT TO THE GOODS AND IS IN LIEU OF AND EXCLUDES ALL OTHER WARRANTIES, EXPRESS OR IMPLIED, ARISING BY OPERATION OF LAW OR OTHERWISE, INCLUDING WITHOUT LIMITATION, MERCHANTABILITY OR FITNESS FOR A PARTICULAR PURPOSE WHETHER OR NOT THE PURPOSE OR USE HAS BEEN DISCLOSED TO SELLER IN SPECIFICATIONS, DRAWINGS, OR OTHERWISE, AND WHETHER OR NOT AGI’S GOODS ARE SPECIFICALLY DESIGNED AND/OR MANUFACTURED BY AGI FOR BUYER’S USE OR PURPOSE.

This limited warranty extends solely to Goods manufactured by AGI and does not cover any third-party parts, components, or materials. To the extent permitted by the manufacturer, AGI will pass on applicable warranties on third-party parts, components or materials to the end-user. This warranty does not extend to any losses or damages due to misuse, use of a kind and/or to a degree not reasonably expected to be made of the Goods, any use of the Goods which is not an intended use as specified in AGI’s published product literature or otherwise specified by AGI in writing, accident, acts of God, abuse, neglect, normal wear and tear (including corrosion and cosmetic issues), any equipment attached to or used in conjunction with the Goods, any field modifications or substitutions to original Goods, component damage incurred during shipping and handling, unauthorized modification or alteration, used beyond rated capacity, or improper installation, maintenance or application.

THE SOLE AND EXCLUSIVE REMEDY FOR ANY CLAIM HEREUNDER SHALL BE LIMITED TO REPAIR, REPLACEMENT, OR REFUND OF THE PURCHASE PRICE. AGI SHALL NOT BE LIABLE FOR DAMAGES CAUSED BY DELAY IN PERFORMANCE AND IN NO EVENT, REGARDLESS OF THE FORM OF THE CLAIM OR CAUSE OF ACTION (WHETHER BASED IN CONTRACT, INFRINGEMENT, NEGLIGENCE, STRICT LIABILITY, OTHER TORT OR OTHERWISE), SHALL AGI’S LIABILITY TO BUYER AND/OR ITS CUSTOMERS EXCEED THE PURCHASE PRICE OF THE GOODS. BUYER AGREED THAT IN NO EVENT SHALL AGI’S

WARRANTY

W-2

LIABILITY TO BUYER AND/OR ITS CUSTOMERS EXTEND TO INCLUDE INCIDENTAL, CONSEQUENTIAL, OR PUNITIVE DAMAGES. THE TERM "CONSEQUENTIAL DAMAGES" SHALL INCLUDE, BUT NOT BE LIMITED TO, LOSS OF ANTICIPATED PROFITS, LOSS OF USE, LOSS OF REVENUE, FAILURE TO MEET GOVERNMENT AND/OR ADMINISTRATIVE REQUIREMENTS, CLEAN UP COSTS, COST OF CAPITAL AND DAMAGE OR LOSS TO OTHER GOODS, PROPERTY OR EQUIPMENT.

To the fullest extent permitted by law, Buyer, on behalf of itself, its suppliers, their agents, employees or any entity or person for which Buyer is or may be responsible ("Indemnitors") shall fully indemnify, save and hold AGI, its agents, employees, officers, directors, partners and related entities harmless from and against all liability, damage, loss, claims, demands, actions and expenses of any nature whatsoever, including, but not limited to reasonable attorney's fees which arise out of or are connected with: (a) any negligent act, error or omission by any Indemnitor in the performance of this agreement; (b) the failure of the Indemnitor to comply with the laws, statutes, ordinances or regulations of any governmental or quasi-governmental authority; or (c) the material breach of any term or condition of this agreement by any of the Indemnitors. Without limiting the generality of the foregoing, the indemnity hereinabove set forth shall include all liability, damage, loss, claims, demands, and actions on account of personal injury, death or property loss to any third party, any Indemnitee, any of Indemnitee's employees, agents, licensees or invitees. The indemnity set forth herein shall survive any termination of this agreement.

THIS WARRANTY IS NON-TRANSFERABLE AND APPLIES ONLY TO THE ORIGINAL END-USER AND SHALL BE CONSIDERED VOID IF NOT REGISTERED WITHIN 30 DAYS OF RECEIPT OF THE GOODS BY THE ORIGINAL END USER.

AGI HUTCHINSON MAYRATH

MANUFACTURED BY
HUTCHINSON | MAYRATH

514 W. Crawford Street
Clay Center, Kansas
USA 67432

TF 800.523.6993
P 785.632.2161
F 785.632.5964

hutchinson-mayrath.com

