



A333/A334/A362/A363 Landing Gear Power Swing Electric and Hydraulic Portable Grain Auger Installation Instructions

This manual applies to:

AGI Westfield MKX², X², MKX, X 10/13 Series

AGI X², X 10/13 Series

AGI Hutchinson HX², HX 10/13 Series

AGI Mayrath HX², HX 10/13 Series



Read and understand the safety information in the Portable Grain Auger manuals before proceeding. Read and understand the instructions in this manual before installing the Landing Gear Power Swing. Fully disengage and lock out the Portable Grain Auger before installing.

Power Swing Components

Electric Power Swing Components

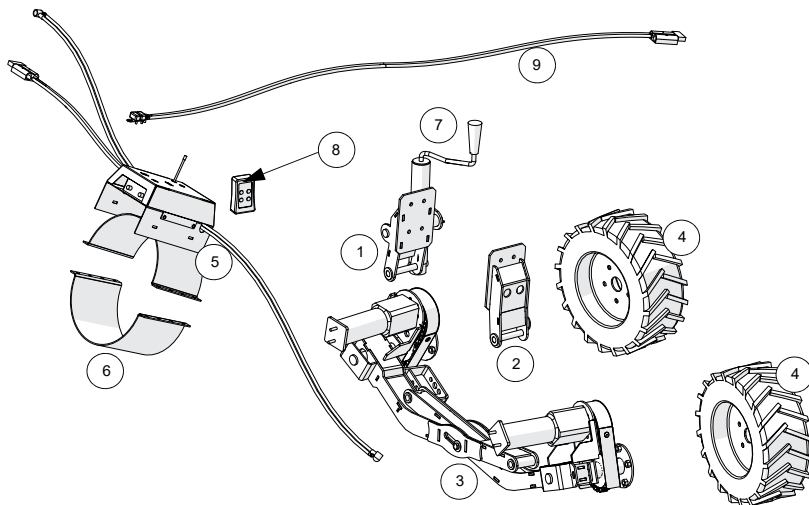

1	manual jack attach bracket	6	hitch ring half clamp
2	right-side attach bracket	7	manual jack
3	landing gear assembly (electric)	8	transmitter
4	landing gear wheels	9	wire harness (battery-to-quick-connect)
5	receiver top-clamp assembly		

Hydraulic Power Swing Components

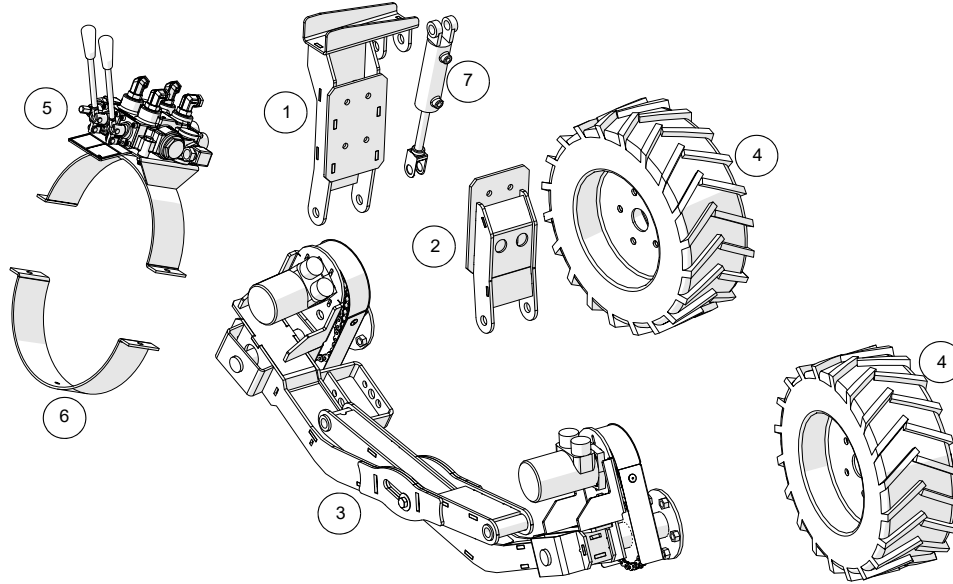

1	hydraulic cylinder attach bracket	7	hydraulic cylinder
2	right-side attach bracket	8	1/2" x 247" hydraulic hose (not shown)
3	landing gear assembly (hydraulic)	9	3/8" x 46" hydraulic hose (not shown)
4	landing gear wheels	10	3/8" x 50" hydraulic hose (not shown)
5	hydraulic control valve assembly	11	3/8" x 80" hydraulic hose (not shown)
6	half clamp		

Tools Required

- 1/2" drive impact wrench (recommended)
- 1/2", 5/8", 3/4" and 1-1/8" sockets, for 1/2" drive
- 1/2", 5/8", 11/16", 3/4", 7/8", 15/16", 1", 1-1/16" and 1-1/8" flat wrenches

Replace the Transition

Note

Applies only to augers with transitions that do not include a welded bracket on each side for landing gear attachment.

1. Remove the hopper and transition from the swing tube.
2. Remove the existing transition from hopper.
3. If applicable, remove the two cable attach brackets from the existing transition and mount to the new transition using the six existing 7/16" x 1-1/4" bolts and lock nuts.
4. Attach the new transition (that includes welded brackets) to the hopper using the two previously-removed 5/8" x 1-1/2" bolts and lock nuts.

Important

Do not over-tighten. Tighten to a slightly loose fit only as these bolts act as pivot points.

5. Open the service door on the transition, then bring the tube and transition together guiding the flight shaft into the u-joint.
6. Secure the transition to the swing tube using the twelve existing 7/16" x 1-1/4" bolts and lock nuts.
7. Tighten set screws on the u-joint, then close and secure the service door.

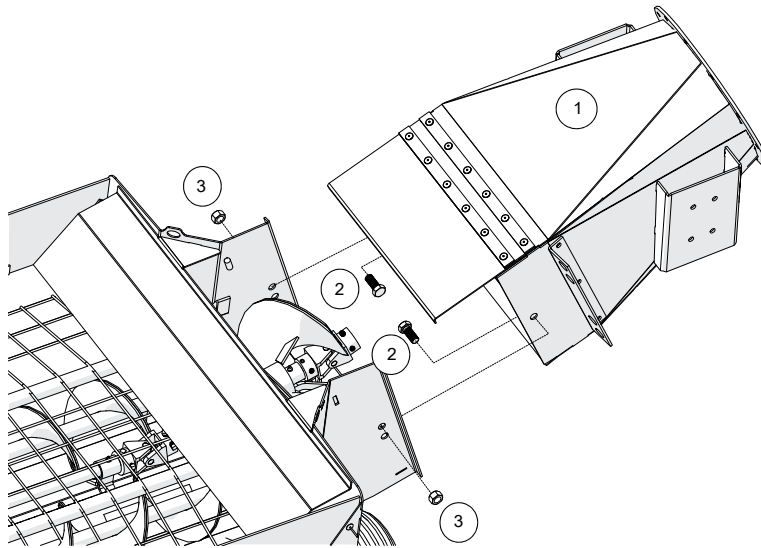

1	transition assembly	3	lock nut, 5/8"
2	bolt, 5/8" x 1-1/2"		

Electric Drive Option

Install the Landing Gear (Electric)

1. Fasten the right-side attach bracket to the right-side transition bracket using four 7/16" x 1-1/4" bolts and lock nuts.
2. Fasten the jack attach bracket to the left-side transition bracket using four 7/16" x 1-1/4" bolts and lock nuts.
3. Slide the upper manual jack attachment onto the manual jack attach pin, and secure using a lynch pin.

4. Connect the landing gear assembly to the attach brackets:
 - a. At the right-side attach bracket, use a landing gear pin and a lynch pin.
 - b. At the jack-attach bracket, use a landing gear pin, three 3/4" rim washers per side (as spacers), and a lynch pin.
5. Align the bottom manual jack attachment with the 5/8" hole in the landing gear attachment point, and secure using a 5/8" x 4" bolt and 5/8" lock nut.
6. Bolt both wheels to the landing gear power swing assembly using five wheel nuts per wheel. Tighten nuts securely.

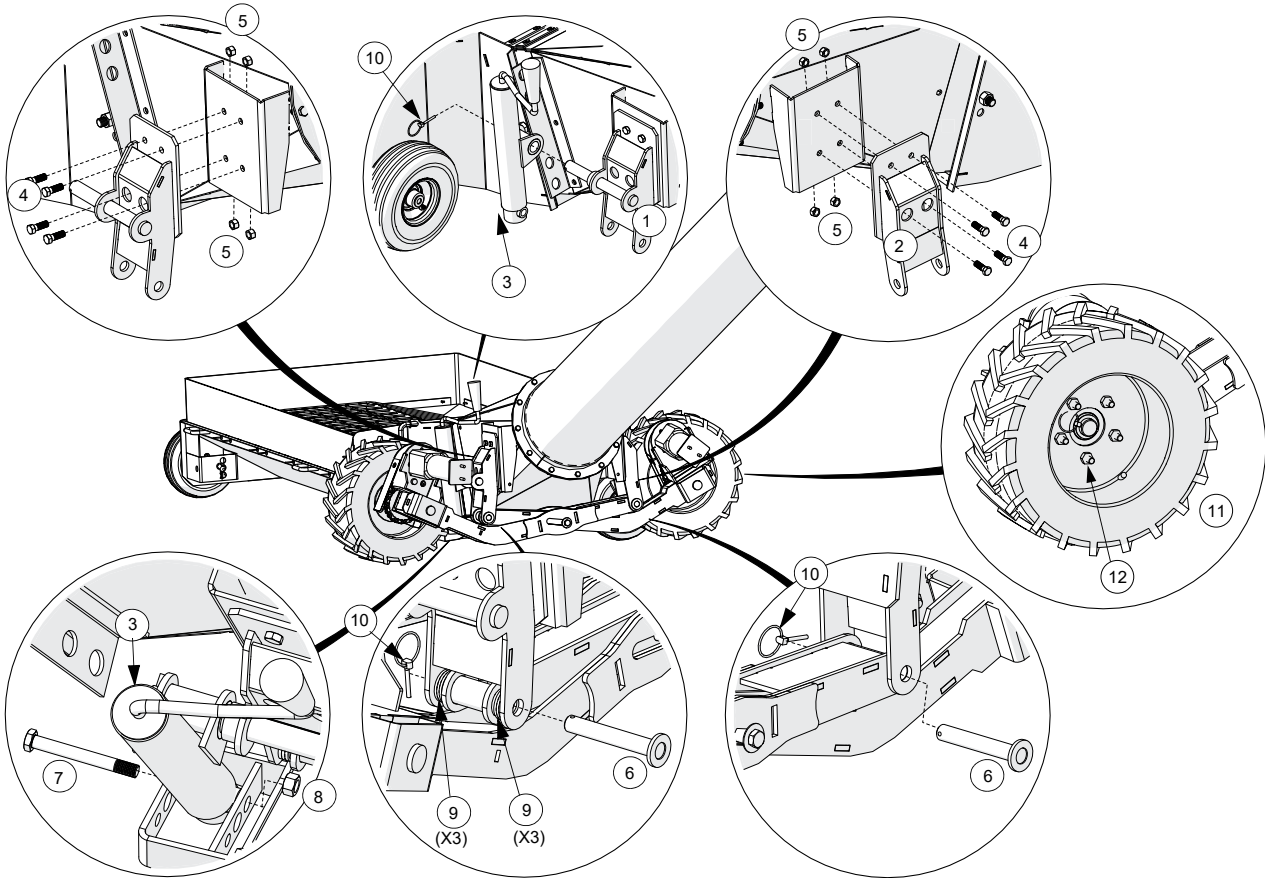

1	jack attach bracket	7	bolt, 5/8" x 4"
2	right-side attach bracket	8	lock nut, 5/8"
3	manual jack	9	rim washer, 3/4"
4	bolt, 7/16" x 1-1/4"	10	lynch pins
5	lock nut, 7/16"	11	wheel (tire on rims)
6	landing gear pins	12	wheel nuts

Install and Connect the Receiver Box

1. Position the receiver top clamp assembly approximately 24" from the transition attach plate and secure using eight 7/16" x 1-1/4" bolts and lock nuts. Tighten both sides securely.
2. Remove cover from the receiver box and top clamp assembly. This means removing the four sheet metal screws located on the sides of the cover.

3. Remove radio antenna and transmitter from the crate (it will be in a separate bag). Screw antenna into the socket on the clamp-base.
4. Replace cover, making sure that the antenna fits through the top hole. Replace sheet metal screws, and tighten securely.

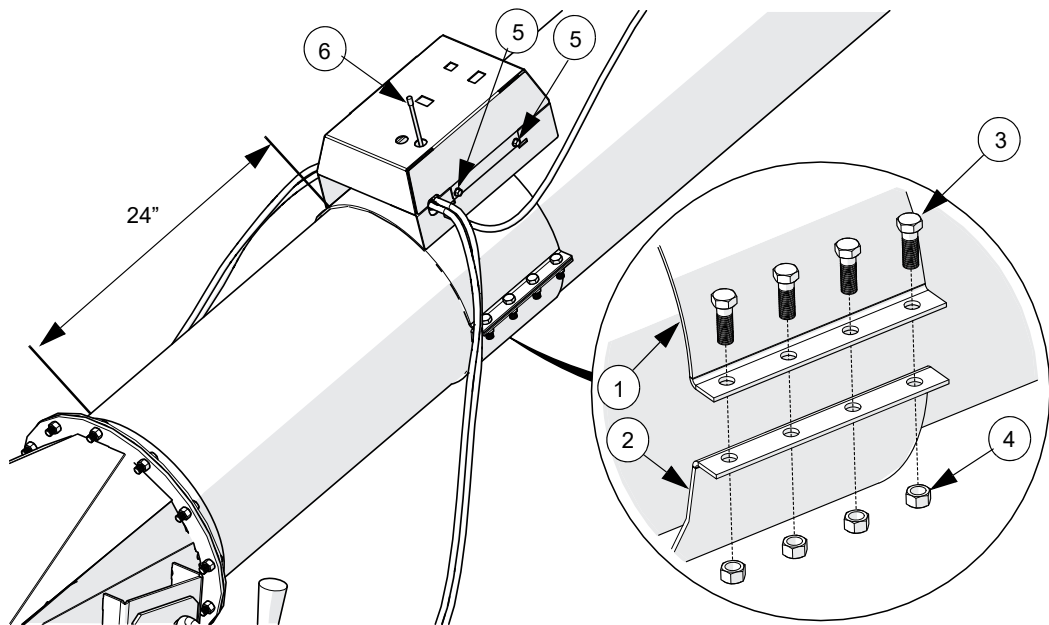

1	receiver top clamp assembly	4	lock nut, 7/16"
2	hitch ring half clamp	5	sheet metal screw, #14 x 5/8"
3	bolt, 7/16" x 1-1/4"	6	antenna

5. The electrical cables are pre-installed to the receiver box. Uncoil the two shorter (4') electrical cables and identify the positive and negative wires. The positive wire has a red boot and printing on it.
6. Attach the wires to the motor terminals on the Power Swing. The positive wire with the red boot connects to the positive (+) terminal on the electric motor. To connect:
 - a. Unscrew the nut on the motor terminal.
 - b. Place the wire on, and then replace the nut.
 - c. Tighten securely.
 - d. Repeat the same steps for the negative wire and terminal.
7. Route the long electrical cable up the swing tube and secure it using an insulated clamp, a 1/4" x 3/4" bolt, and a 1/4" lock nut.
8. Uncoil the tractor wire harness.
9. Connect the end opposite the quick-connect to the battery and chassis ground using the 5/16" lugged connectors supplied with the kit:
 - a. Attach the positive wire directly to the positive terminal on the tractor battery (the positive wire has a circuit breaker on it).
 - b. Attach the negative wire to a tractor chassis ground point (assuming that the tractor battery is also grounded to the chassis).

NOTICE

If these electrical cables are not hooked up properly the electric controller will be damaged.

10. Attach the receiver cable quick connect to the tractor wire harness quick connect.

Note

Ensure that both tires are turning in the same direction. If they are not, reverse the wires on one of the motors.

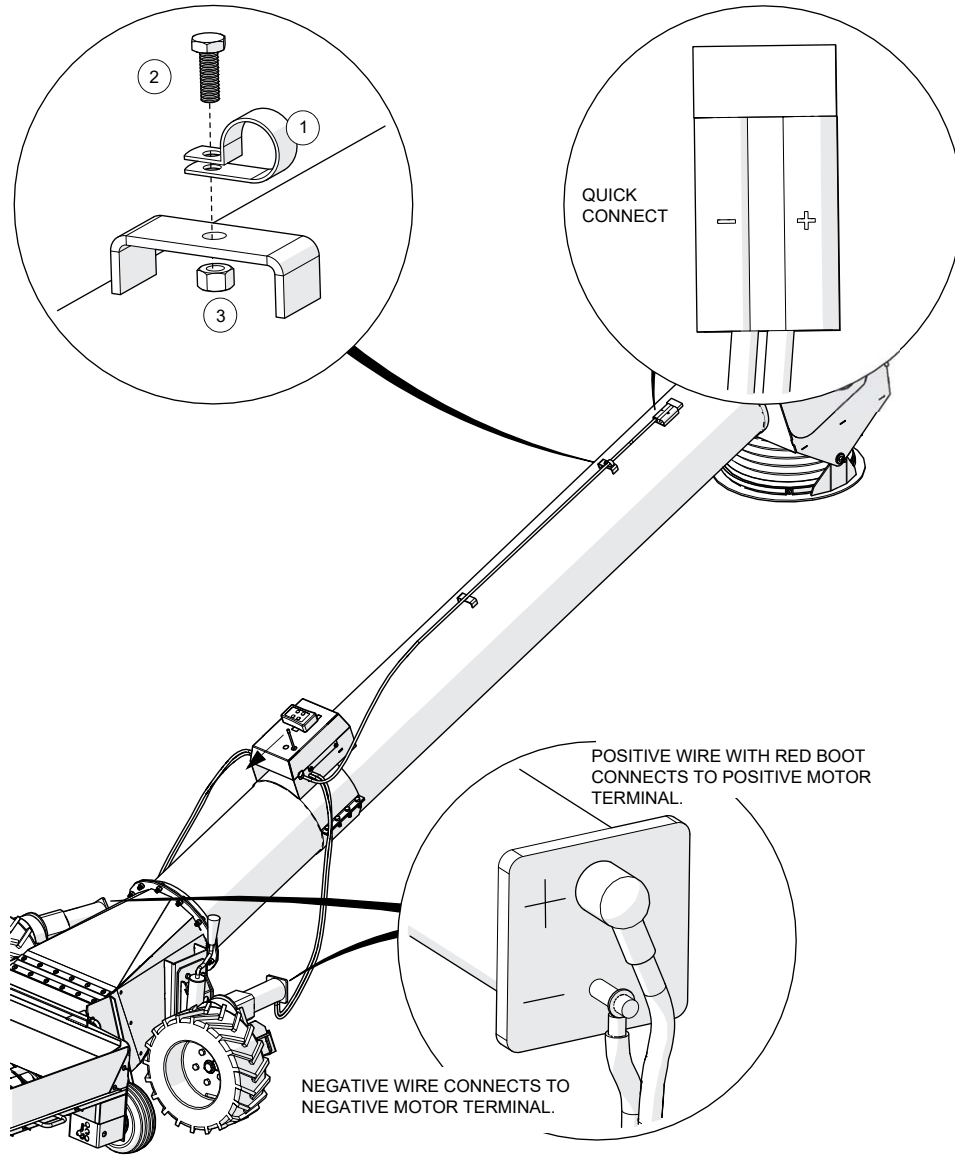

1	insulated clamp, 5/8" x 1/2"	3	lock nut, 1/4"
2	bolt, 1/4" x 3/4"		

Figure 1. Power Swing Wiring Diagram

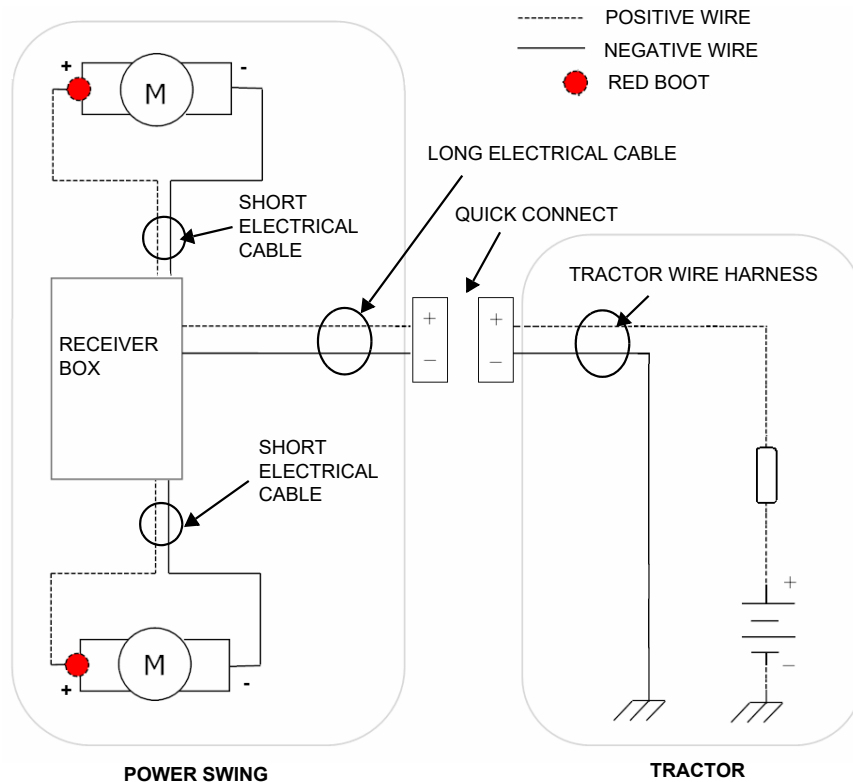

Hydraulic Drive Option

Attach the Landing Gear to the Transition

1. Fasten the right-side attach bracket to the right-side transition bracket using four 7/16" x 1-1/4" bolts and lock nuts.
2. Fasten the hydraulic cylinder attach bracket to the left-side transition bracket using four 7/16" x 1-1/4" bolts and lock nuts.
3. Connect the landing gear power swing assembly to the attach brackets on the transition:
 - a. At the right-hand attach brackets, use a landing gear pin and a lynch pin.
 - b. At the hydraulic cylinder attach bracket, use a landing gear pin, three 3/4" rim washers per side (as spacers), and a lynch pin.
4. Align the cap end of the hydraulic cylinder with the mounting flange on the hydraulic cylinder attach bracket, and the rod end with the landing gear cylinder mount flange. Secure the cylinder using a 3/4" x 3-1/2" bolt and lock nut on the cap end, and a 3/4" pin, a spacer bushing, two 3/4" washers, and a lynch pin on the rod end.
5. Bolt both wheels to the landing gear power swing assembly using five wheel nuts per wheel. Tighten nuts securely.

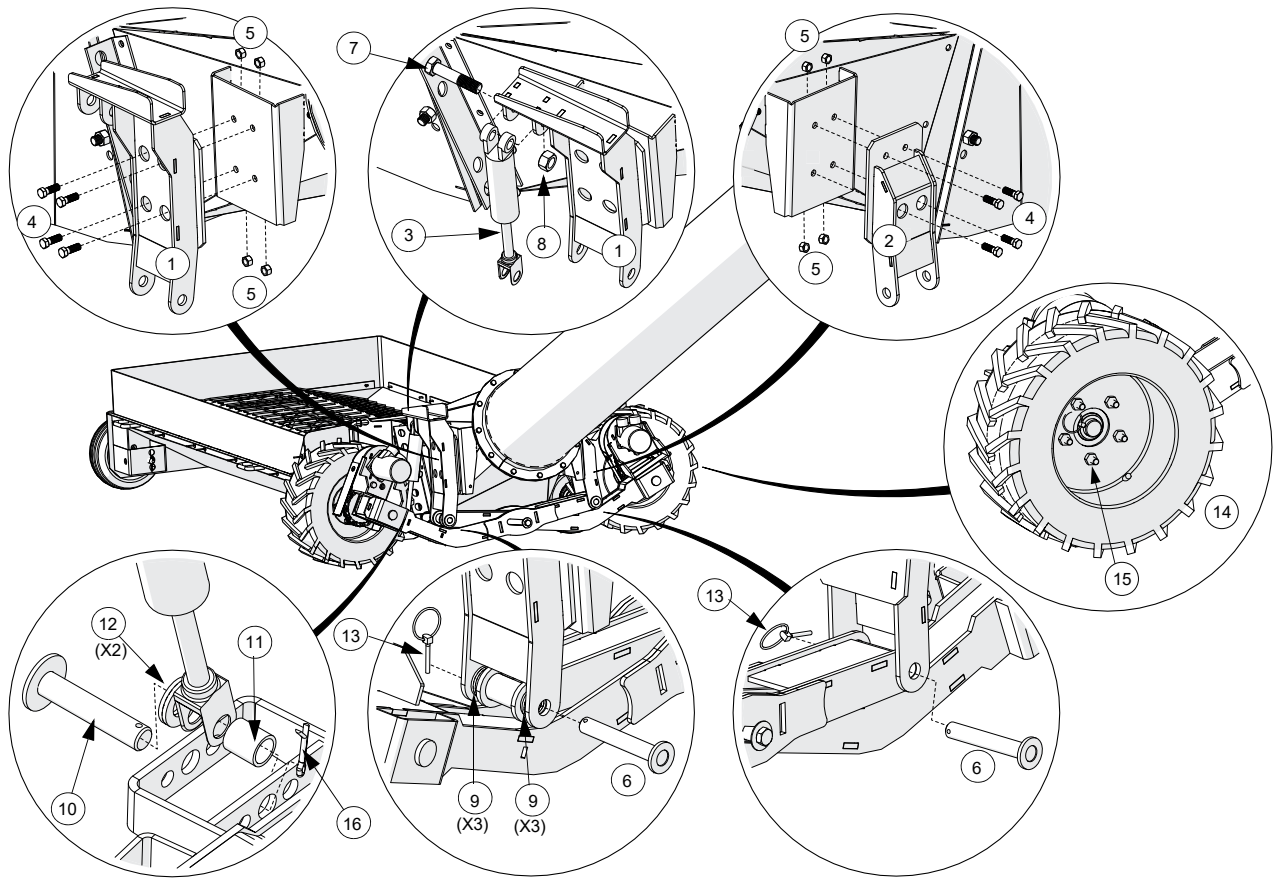

1	hydraulic cylinder attach bracket	9	rim washer, 3/4"
2	right-side attach bracket	10	pin, 3/4"
3	hydraulic cylinder	11	spacer bushing
4	bolt , 7/16" x 1-1/4"	12	washer, 3/4"
5	lock nut, 7/16"	13	lynch pin
6	landing gear pin	14	wheel (tire on rim)
7	bolt , 3/4" x 3-1/2"	15	wheel nuts
8	lock nut, 3/4"	16	cotter pin

Install and Connect the 2-Spool Valve

Note

The 2-Spool hydraulic control valve can be converted between closed center and open center. See Operator's manual. To determine whether your hydraulic system is an open system or a closed system, check your tractor manual.

1. Position the 2-spool valve assembly at a 20° angle away from the main auger tube and approximately 24" from the transition attach plate. Secure using two 7/16" x 1-1/4" bolts and lock nuts.
2. Install two elbow fittings into the power swing hydraulic cylinder ports. Connect two hydraulic hoses between the 2-spool valve and the power swing hydraulic cylinder.
3. Install two 45° fittings into the left power swing hydraulic motor ports. Connect one hydraulic hose between the 2-spool valve and the left power swing hydraulic motor.

4. Install two 45° fittings into the right power swing hydraulic motor ports. Connect one hydraulic hose between the 2-spool valve and the right power swing hydraulic motor.
5. Connect one hydraulic hose between the two power swing hydraulic motors.
6. Secure the two hoses from the right power swing hydraulic motor to the transition using four line blocks and two 5/16" x 2-1/2" bolts, flat washers and lock nuts.
7. Connect the hydraulic supply and return hoses to the 2-spool valve and run the hoses up the swing tube to the tractor. Secure hoses to the swing tube using two line blocks, a 5/16" x 2-1/2" bolt, flat washer, and lock nut.
8. Install 1/2" pioneer couplers onto the other end of the hydraulic supply and return hoses.

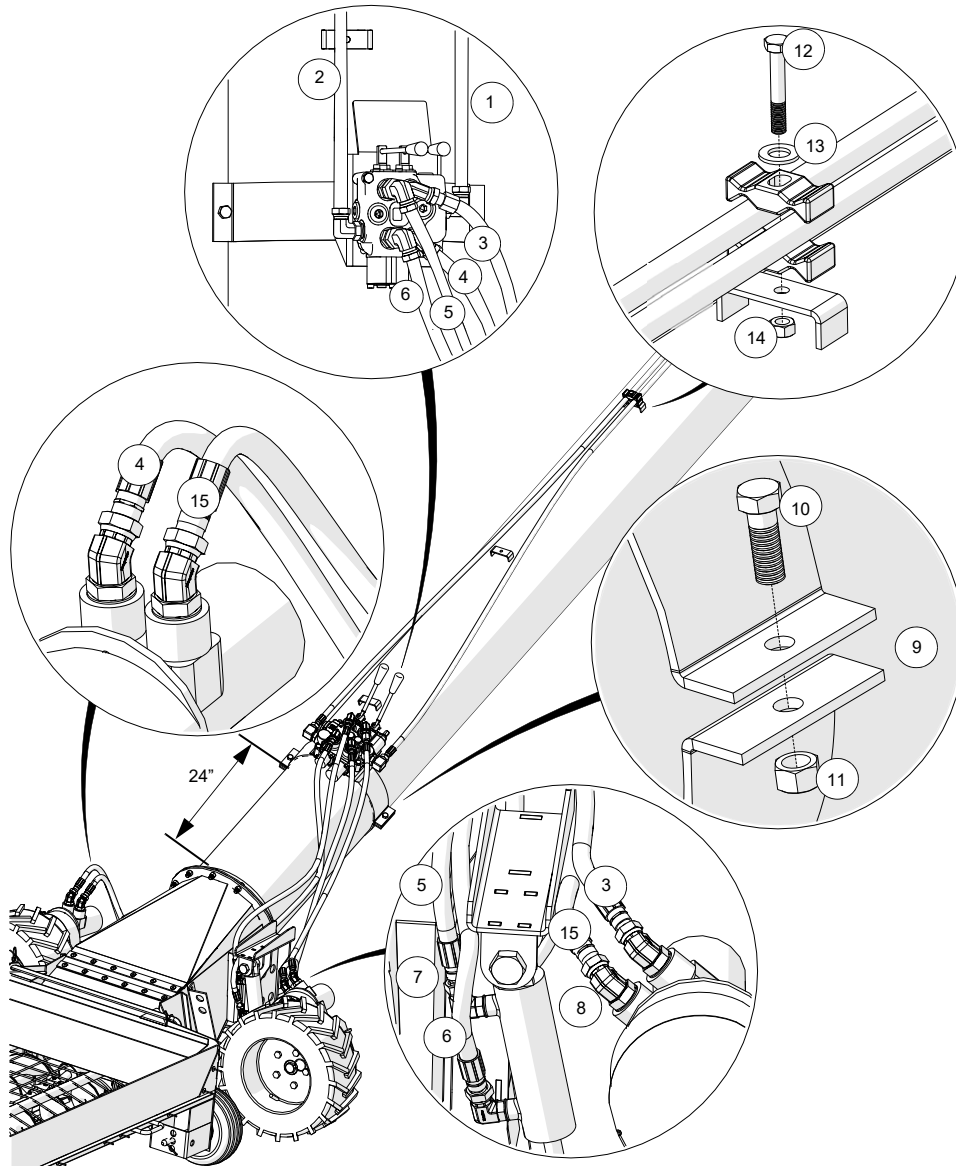

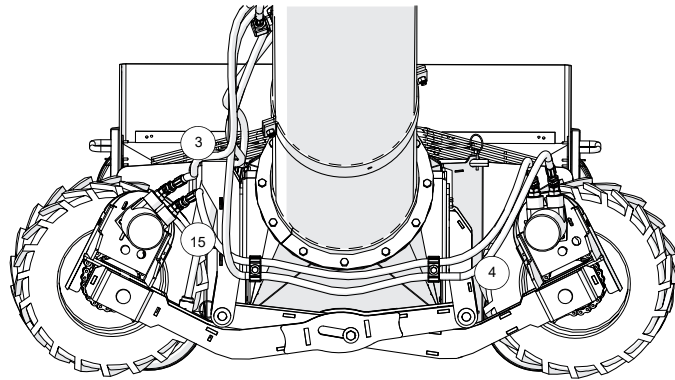

1	hydraulic hose (supply), 1/2" x 247"	9	hydraulic valve assembly (top)
2	hydraulic hose (return), 1/2" x 247"		half-clamp (bottom)
3	hydraulic hose (power swing motor), 3/8" x 46"	10	bolt, 7/16" x 1-1/4"
4	hydraulic hose (power swing motor), 3/8" x 80"	11	lock nut, 7/16"
5	hydraulic hose (power swing cylinder), 3/8" x 46"	12	bolt, 5/16" x 2-1/2"
6	hydraulic hose (power swing cylinder), 3/8" x 50"	13	flat washer, 5/16"
7	steel elbow, 6 MORB x 3/8 NSPM	14	lock nut, 5/16"
8	adapter, 45 Deg, #10 MORB x #6 FNPSM	15	hydraulic hose, 3/8" x 50"

Install the Double Hose Holder

This section does not apply to MKX² 13, X² 13, and HX² 13 models.

1. Attach the double hose holder to the PTO bracket with a 3/8" x 1" bolt and lock nut.

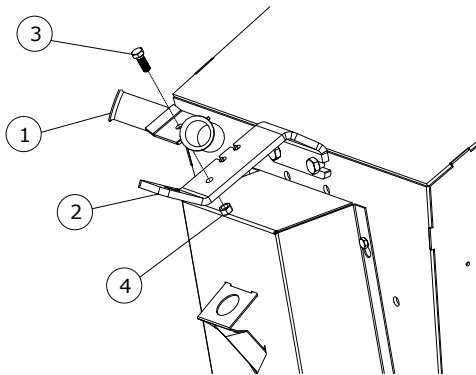

1	double hose holder
2	PTO bracket
3	bolt, 3/8" x 1"
4	lock nut, 3/8"

AGI is a leading provider of equipment solutions for agriculture bulk commodities including seed, fertilizer, grain, and feed systems with a growing platform in providing equipment and solutions for food processing facilities. AGI has manufacturing facilities in Canada, the United States, the United Kingdom, Brazil, South Africa, India and Italy and distributes its products globally.



P.O. Box 39, Rosenort, Manitoba, R0G 1W0 Canada
P 866.467.7207 (Canada & USA) or 204.746.2396 | F 866.768.4852 | E sales@grainaugers.com

AGGROWTH.COM aggrowthintl
©Ag Growth International Inc. 2026 | Printed in Canada