



Electric Clutch Kit Double-Groove Pulley Installation Instructions

This manual applies to:

STX and R Series (excluding 10-51 models)

Install the Electric Clutch

Note

The instructions in this manual assumes installation during assembly of a new auger. If this kit is installed after initial auger assembly, some procedure detail may differ.

- Refer to Figure 1 for installation detail for typical engines.
 - Refer to Figure 2 for installation detail for Vanguard engines.
1. Mount the hydraulic pump bracket (1) to the engine plate using two 3/8" x 1-1/4" bolts (2), lock washers (3) and flat washers (4).
 - ➡ • **For Vanguard engines:** Install two 1/2" lock washers (5) to create a level mount between the engine block and pump bracket. The stop bracket shares a mounting point with the pump bracket. Use the pump bracket hardware to mount the clutch stop loosely to the pump bracket.
 2. Slide the square shaft key (6) and lower pump pulley (7) onto the engine shaft.
 3. Slide the electric clutch (8) onto the engine shaft and secure it with a 3/8" x 3" bolt (9) or 7/16" x 3" bolt (9) (engine-model dependent) and lock washer (10).

Note

When properly adjusted the electric clutch should be tight and unable to slide on the shaft.

4. Connect all belts.
- ➡ 5. **For typical engines:** Position the stop bracket (11) the pump bracket so that it fits into the clutch case slot to prevent the clutch from rotating, and secure it with a 3/8" x 1-1/4" bolt (12), lock washer (13), flat washer (14), and lock nut (15).
- ➡ 6. **For Vanguard engines:** Adjust the stop bracket (11) the pump bracket so that it fits into the clutch case slot to prevent the clutch from rotating, and secure it by tightening the shared pump bracket bolt.

Figure 1. Installing the Electric Clutch, Typical Engine

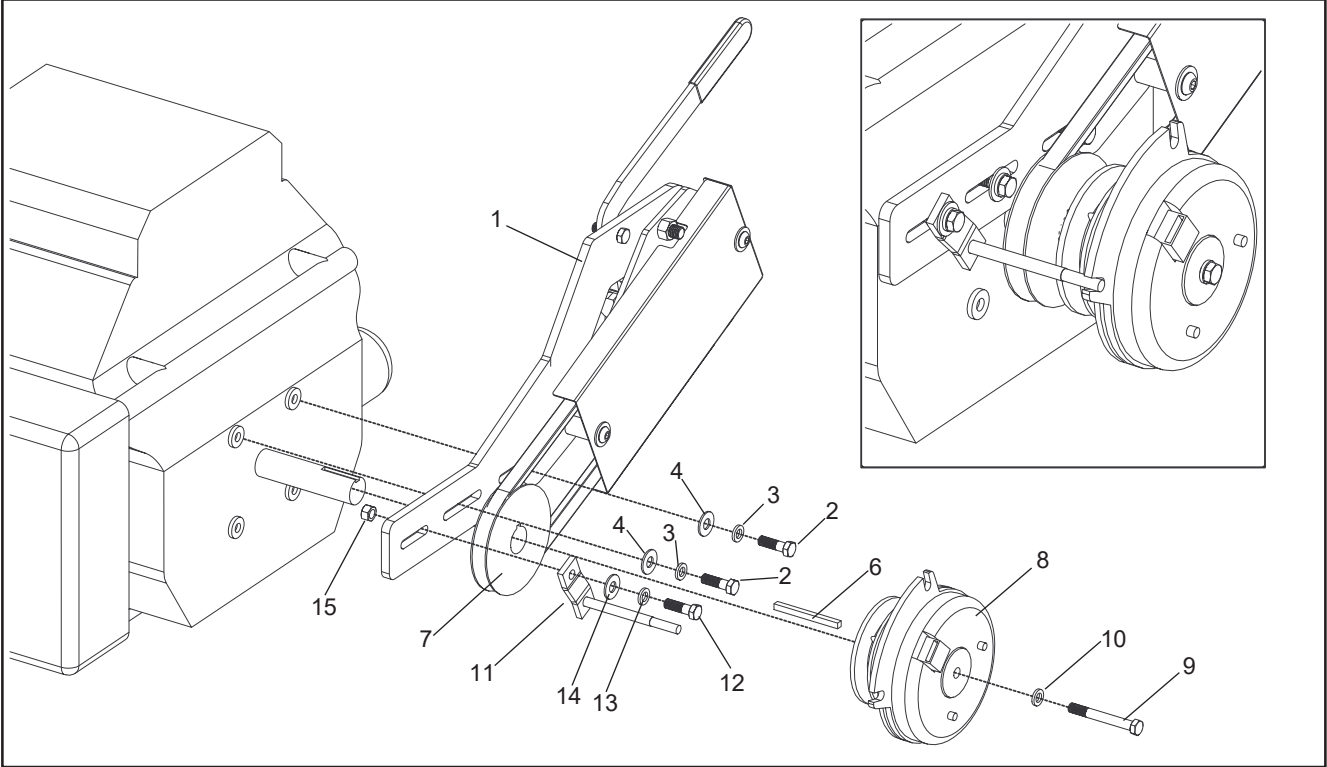
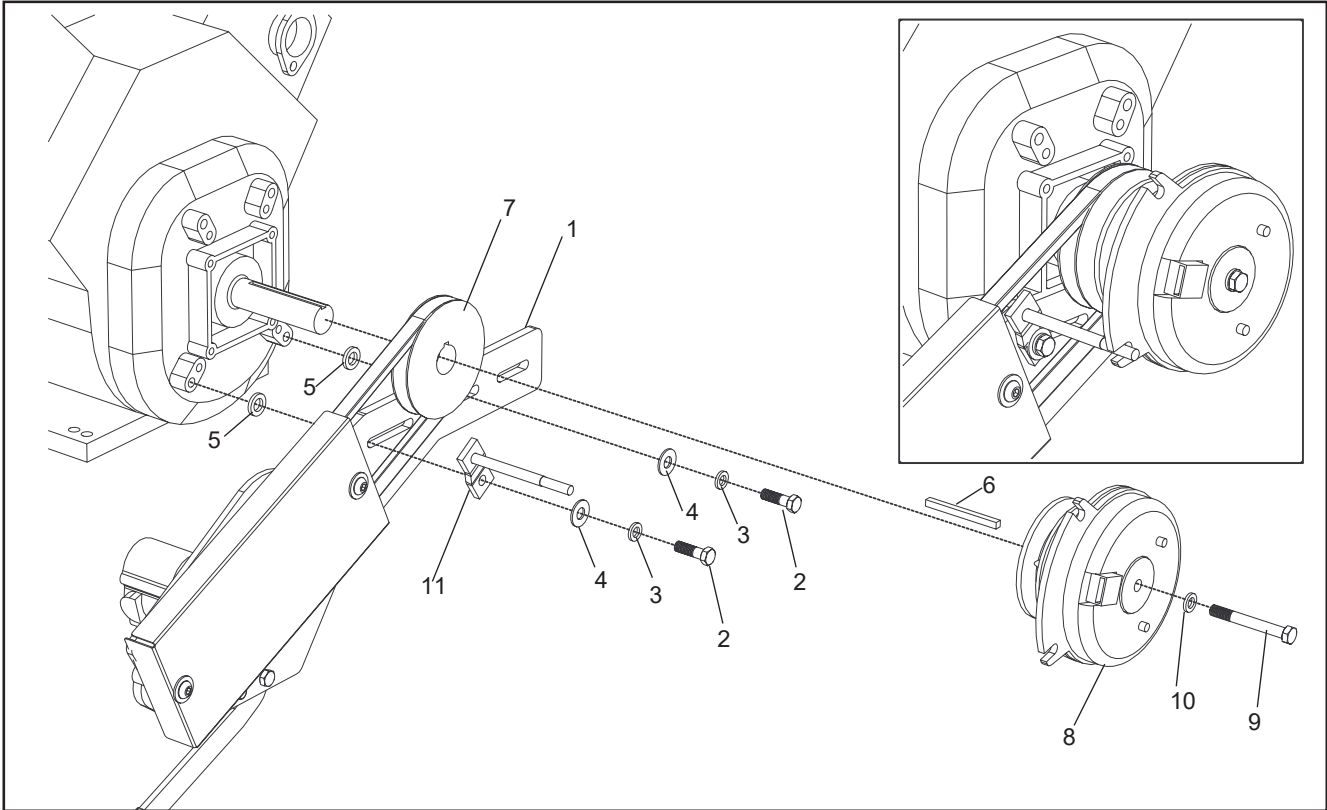

Figure 2. Installing the Electric Clutch, Vanguard Engine



Wire the Electric Clutch

1. Plug the clutch wiring harness into the clutch, and position the other end of the harness in a way that leaves it accessible for external wiring.
2. Complete the remaining electrical connections, using 14 gauge crimp connectors (splice, spade, and ring terminal) as needed (see Figure 3):
 - connect the white switch cable wire to one of the clutch harness connector terminals;
 - connect the black switch cable wire to the fuse, and from there to 12 VDC power;
 - connect the remaining clutch harness connector terminal to ground.
3. Test the switch to ensure that the electric clutch engages and disengages properly.
4. Use electrical tape to seal and secure any electrical connections that might require weather-proofing.
5. Secure the electrical cable to a frame cable-ties or other equivalent fasteners to prevent accidental disconnection of wiring if the cable is pulled tight.
6. Secure the cable when not in use.

Figure 3. Electric Clutch Wiring Diagram

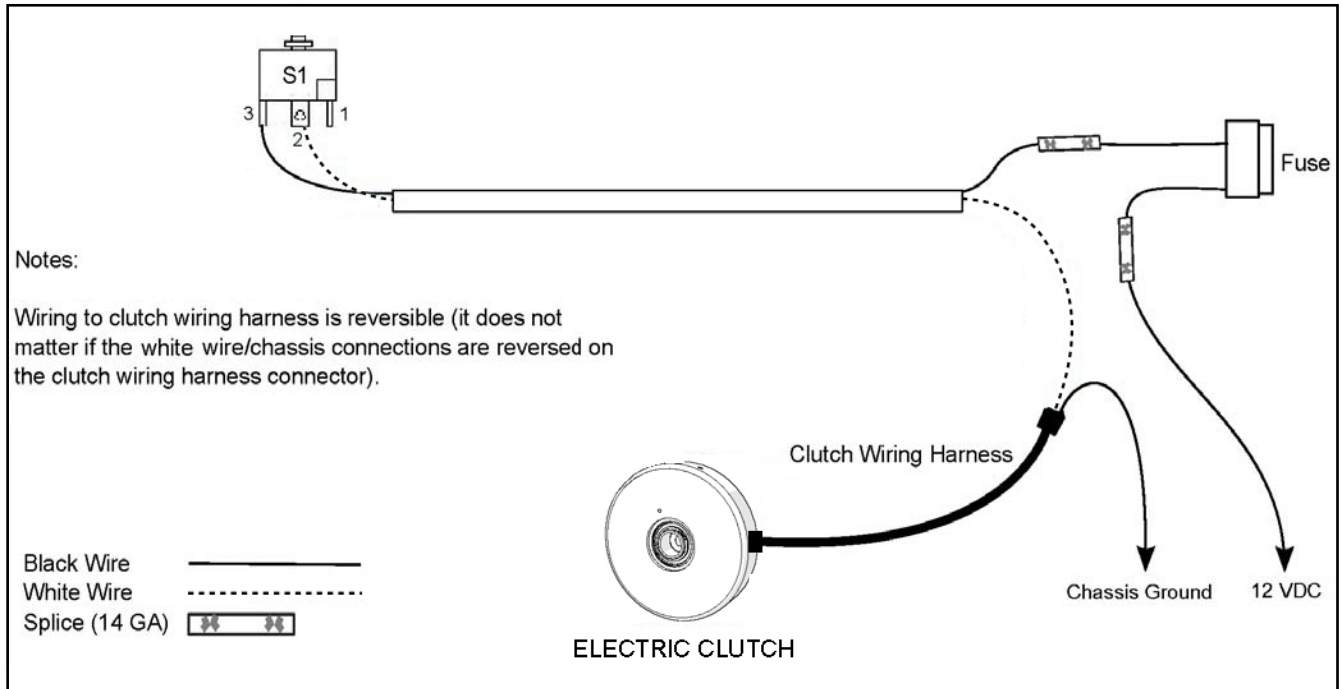

Milltec is an AGI Brand.

AGI is a leading provider of equipment solutions for agriculture bulk commodities including seed, fertilizer, grain, and feed systems with a growing platform in providing equipment and solutions for food processing facilities. AGI has manufacturing facilities in Canada, the United States, the United Kingdom, Brazil, South Africa, India and Italy and distributes its products globally.



51-A, 1st Phase, KIADB Industrial Area, Bommasandra Bangalore-560099, India
 P +91.80.27831128 | F +91.80.27831129 | E milltec@milltecmachinery.com

AGGROWTH.COM agrowthintl [Social Media Icons]
 ©Ag Growth International Inc. 2025 | Printed in India